

# Single Output Module ESMI EM201EA

Instruction Sheet  
R10258GB0



## **Schneider Electric Fire & Security Oy**

Sokerilinnantie 11 C  
FI-02600 Espoo, Finland  
Tel: +358 10 446 511  
Website: [www.se.com](http://www.se.com)  
Document number: R10258GB0  
Published: 12.05.2021

© 2021 – Schneider Electric. All Rights Reserved. This information is only to be used as guidance. Subject to changes and errors.

# Contents

<b>1</b>	<b>Single Output Module ESMI EM201EA</b>	<b>4</b>
1.1	Addressable EM200-series I/O-modules	4
1.2	Specifications	4
1.3	Dimensions	5
1.4	Address setting	5
1.5	Installation	6
1.6	Single Output ESMI EM201EA Module Wiring	7
1.6.1	Single Output Module ESMI EM201EA with Supervised Output	7
1.6.2	Single Output Module ESMI EM201EA with Unsupervised Output	8

# 1 Single Output Module ESMI EM201EA

The SINGLE OUTPUT MODULE - ESMI EM201EA (FFS06717011) is part of the EM200 series of modules are a family of microprocessor-controlled interface devices permitting the monitoring and/or control of auxiliary devices and are compatible Esmi Sense FDP and FX 3NET fire detection system.

## 1.1 Addressable EM200-series I/O-modules

Compact construction enables more units to be mounted in installation boxes.

A single tri-colour LED indicates the status of the module. In normal conditions, the LED can be set by command from the control panel to blink green when the module is polled. When the control panel switches the relay to the energised state the LED can be set to continuous green.

All EM200 series modules are provided with short circuit monitoring and isolators on the intelligent loop. If required the isolators may be wired out of the loop to facilitate the use of the modules on high current loaded loops, for example if sounders are used. To achieve this, the loop out positive should be wired to terminal 5 rather than terminal 2. See the relevant wiring diagram for details.

## 1.2 Specifications

Operating Voltage Range:	15 to 32VDC (Min 16.5VDC for LED operation)
Maximum Standby Current:	160 $\mu$ A - No Communication
LED Current (Red):	1.5 mA
LED Current (Yellow):	5.5 mA
Isolator features:	see S00-7100
Humidity:	5% to 95% relative humidity (non-condensing)
Maximum Wire Gauge:	2.5 mm <sup>2</sup>

1.3

Dimensions

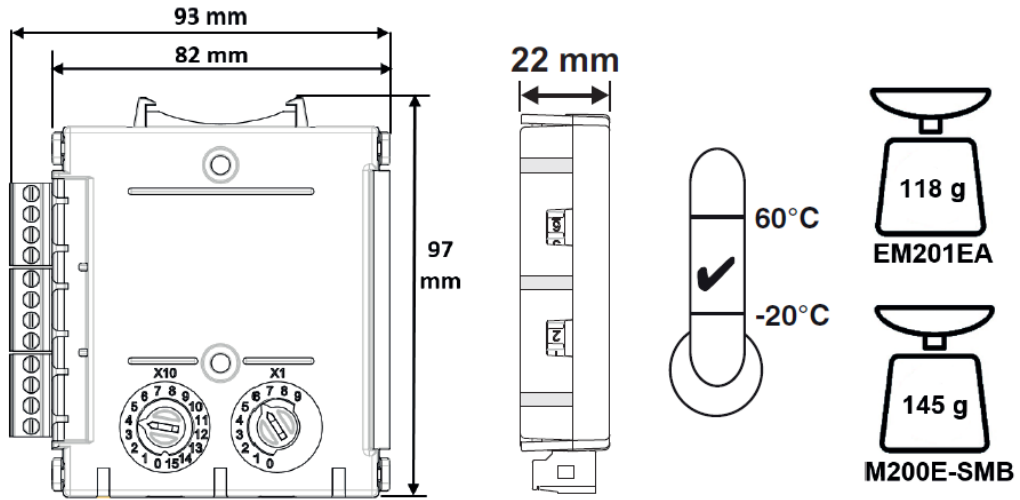

1.4

Address setting

All modules are addressable. The address setting is done with two rotary switches, accessible either on the wide side or the front edge, depending on means of mounting. The dual input and dual input – single output modules are automatically assigned to two and three consecutive addresses.

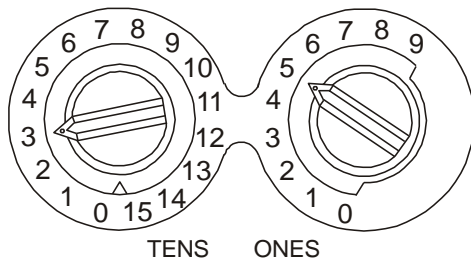
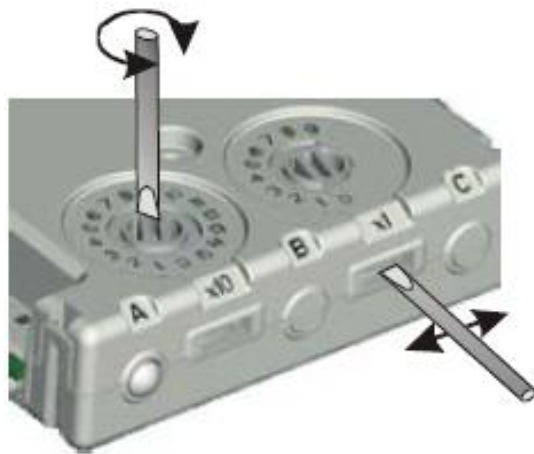

Rotary switches

## 1.5 Installation

**Note:** These modules must only be connected to control panels using compatible proprietary analogue addressable communication protocols for monitoring and control. EM200 series modules can be mounted in several ways (See below):

The surface mounting box has a transparent cover that enables verification of address setting and visibility of LEDs, without cover removal.

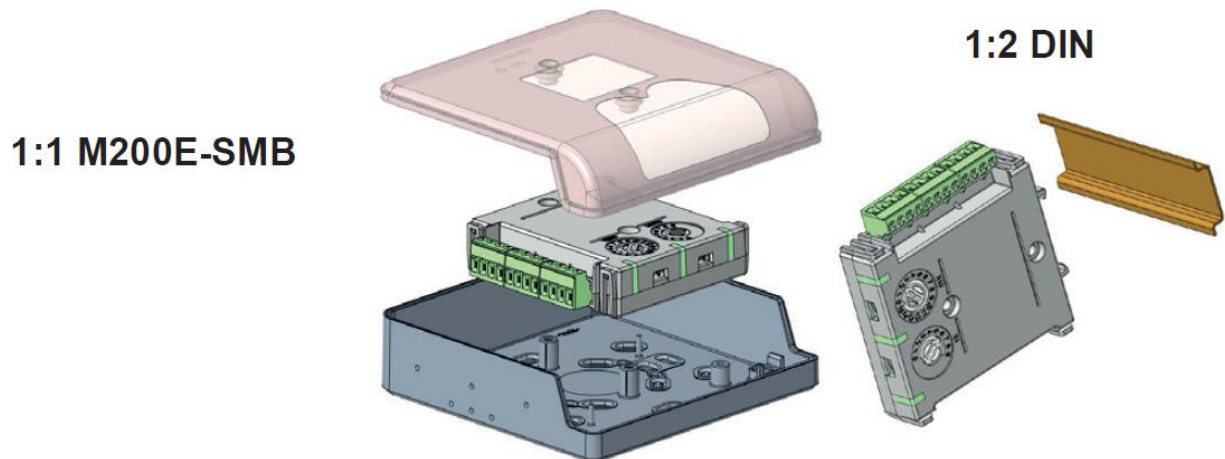

**1:1** An M200E-SMB custom low profile surface-mounting box. The SMB Base is affixed to mounting surface, and then the module and cover are screwed onto the base using the two screws supplied. Box dimensions: 132 mm (H) x 137 mm (W) x 40 mm (D)

**1:2** The DIN bracket on top allows mounting onto standard 35 mm x 7.5 mm "Top Hat" DIN rail inside a control panel or other suitable enclosure. Push module into adaptor bracket until it clips into place. Locate top clip over DIN rail and rotate bottom down to clip into place. To remove, lift up, then rotate top away from the rail.

Wiring to all series EM200 modules is via plug in type terminals capable of supporting conductors up to 2.5 mm<sup>2</sup>.

## 1.6 Single Output ESMI EM201EA Module Wiring

The Single Input Module EM201EA can be wired for either Supervised or Non-Supervised operation respectively.

### 1.6.1 Single Output Module ESMI EM201EA with Supervised Output

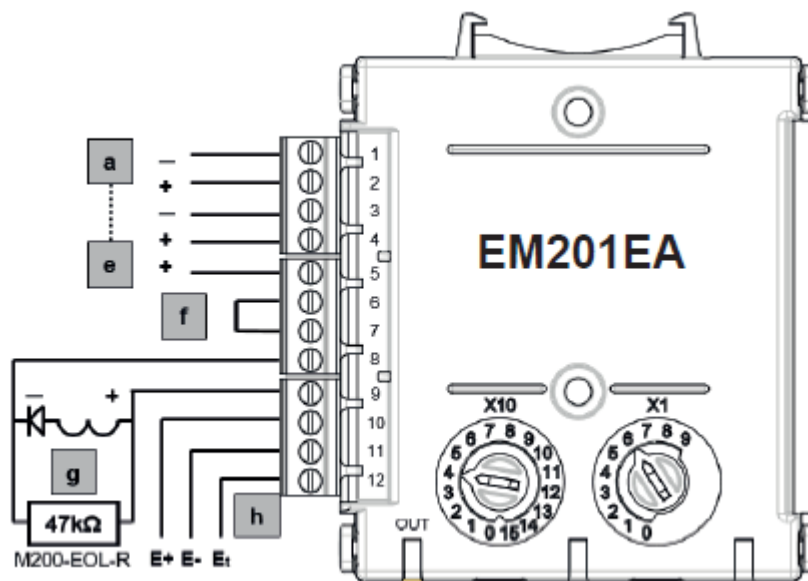

When the module is used in supervised mode and power is supplied to the module, a switched negative input on terminal 12 can be used to signal an external fault condition, such as a power supply fault. Loss of power is also supervised in this mode such that if the supply voltage falls below 7V a fault indication is achievable. Note that the use of this fault mode is dependent on panel software.

PSU monitoring is not available when the module switches the output to **Alarm**.

**a:** T1 Loop Output -. **b:** T2 Loop Output +. **c:** T3 Loop Input -. **d:** T4 Loop Input +

**e:** T5 Loop Output +. If short circuit isolation is not required, loop output+ should be wired to terminal 5 and not 2. Terminal 5 is internally connected to terminal 4.

**f:** To enable output circuit supervision, the link supplied must be fitted across terminals 6 and 7, and the load must be polarised.

**h:** External power supply max. 32V DC, min. 7V DC. In supervised mode, the module monitors the power supply voltage across terminals 10 and 11 to ensure it does not drop below 7V, and also monitors for a switched negative fault signal from the power supply to terminal 12 (optional). If a fault is seen the yellow LED will blink, and a fault may be indicated at the panel. The use of these fault warnings is dependent on panel software; please refer to your panel supplier.

1.6.2 Single Output Module ESMI EM201EA with Unsupervised Output

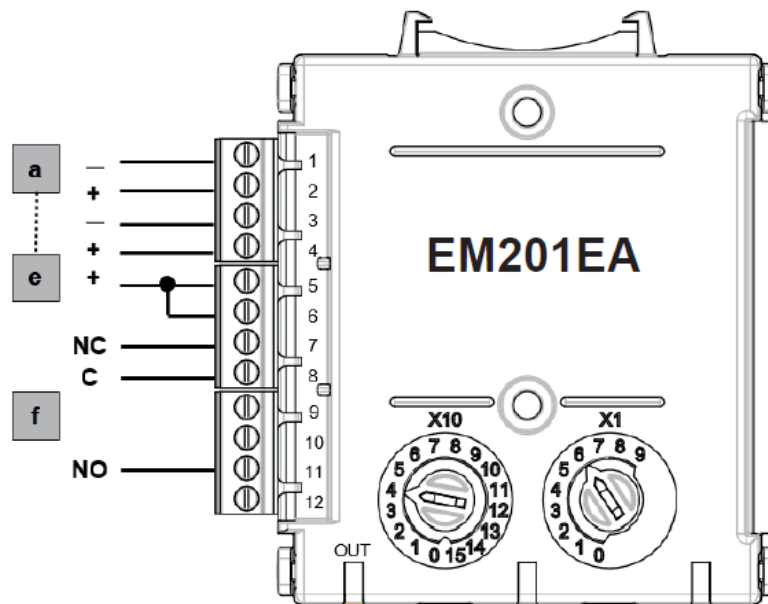

To use the module in unsupervised mode, connect terminal 6 to Loop + (for example terminal 5) and wire as follows (see Figure 3):

**a:** T1 Loop Output -. **b:** T2 Loop Output +. **c:** T3 Loop Input -. **d:** T4 Loop Input +

**e:** T5 Loop Input +. If short circuit isolation is not required, loop output+ should be wired to terminal 5 and not 2. Terminal 5 is internally connected to terminal 4.

**f:** Relay contact rating: 30V DC, 2A resistive load.

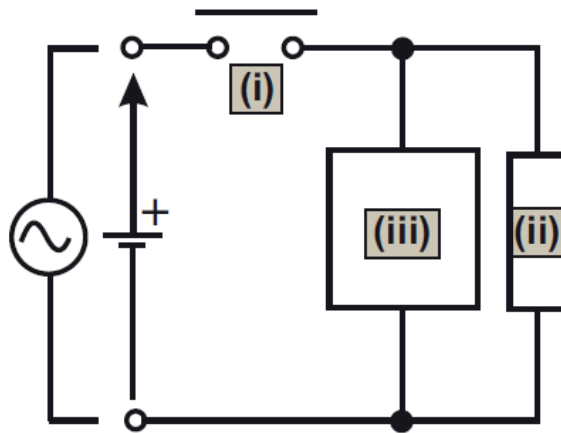

**Warning! Switching inductive loads**

Inductive loads can cause switching surges, which may damage the module relay contacts **(i)**.

To protect the relay contacts, connect a suitable Transient Voltage Suppressor **(iii)** - for example 1N6284CA - across the load **(ii)** as shown in figure 5.

Alternatively, for unsupervised DC applications, fit a diode with a reverse breakdown voltage greater than 10 times the circuit voltage.