



Ledinaire Slim Downlight DN065B G2 & DN065C

DN065B G2 LED10/830 11W 220V D150 RD EU

830 warm white - Power supply unit - White

The LEDINAIRE range contains a selection of popular off-the-shelf LED luminaires that come with the high Philips quality levels at a competitive price. Reliable, energy-efficient and affordable – just what you need

Product data

General Information	
Light source color	830 warm white
Light source replaceable	No
Driver/power unit/transformer	Power supply unit
Driver included	Yes
Optic type	Beam angle 110°
Luminaire light beam spread	110°
Connection	Connection unit 2-pole
Cable	Cable 0.2 m with cable connector
Protection class IEC	Safety class II
Glow-wire test	Temperature 650 °C, duration 30 s
Flammability mark	For mounting on normally flammable surfaces
Warranty period	5 years
Constant light output	No
Number of products on MCB of 16 A type B 48	

EU RoHS compliant	Yes
Operating and Electrical	
Input Voltage	220 to 240 V
Input Frequency	50 or 60 Hz
Inrush current	4.03 A
Inrush time	0.272 ms
Power Factor (Min)	0.75
Controls and Dimming	
Dimmable	No
Mechanical and Housing	
Housing Material	Metal-Plastic
Reflector material	Polycarbonate
Optic material	Polycarbonate

Ledinaire Slim Downlight DN065B G2 & DN065C

Optical cover/lens material	Polycarbonate
Fixation material	Steel
Optical cover/lens finish	Matte
Overall height	45 mm
Overall diameter	175 mm
Color	White
Dimensions (Height x Width x Depth)	45 x NaN x NaN mm (1.8 x NaN x NaN in)

Approval and Application

Ingress protection code	IP20(front IP40)
Mech. impact protection code	IK03 [0.3 J]

Initial Performance (IEC Compliant)

Initial luminous flux (system flux)	950 lm
Luminous flux tolerance	+/-10%
Initial LED luminaire efficacy	86.00 lm/W
Init. Corr. Color Temperature	3000 K
Init. Color Rendering Index	80
Initial chromaticity	(0.4367, 0.3933) 5SDCM
Initial input power	11 W

Power consumption tolerance	+/-10%
-----------------------------	--------

Application Conditions

Ambient temperature range	-20 to +40 °C
Suitable for random switching	No

Product Data

Full product code	871869967939200
Order product name	DN065B G2 LED10/830 11W 220V D150 RD EU
EAN/UPC - Product	8718699679392
Order code	929002220432
Numerator - Quantity Per Pack	1
Numerator - Packs per outer box	12
Material Nr. (12NC)	929002220432
Net Weight (Piece)	0.210 kg



Dimensional drawing

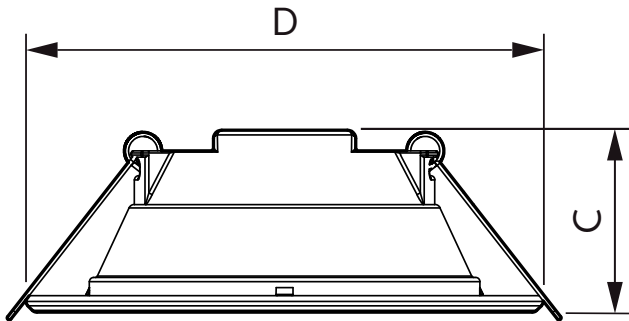

DN065B G2 LED10/830 11W 220V D150 RD EU

Product	D	C
DN065B G2 LED10/830 11W 220V D150 RD EU	175 mm	45 mm

Photometric data

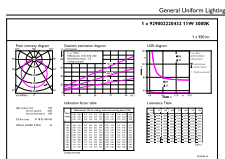

General Lighting
1 • 1000000000 11W 220V

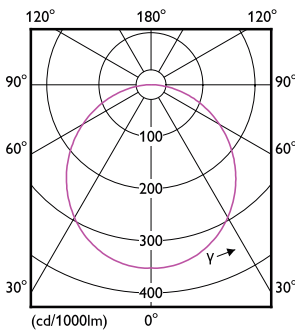

Downlight DN065B G2 LED10 830 D150 RD EU

Downlight DN065B G2 LED10 830 D150 RD EU

Ledinaire Slim Downlight DN065B G2 & DN065C

