

THORGEON

SENSORS

MICROWAVE SENSOR

02019



Scan me

www.thorgeon.com/02019

Manufactured in PRC



LED
POWER
300W

180/360°

15m

TIME

LUX

Hz
50-60

220-240V

1.5-3.5m

INDOOR

-20°C

+40°C

IP20

CE EAC UK CA 

THORGEON



www.thorgeon.com

SIA "ATTA-1", Daugavgrivas street 77,
Riga, Latvia, LV-1007



4751029894069

Developed in Latvia

MICROWAVE SENSOR

The product is a new saving-energy switch; it adopts microwave sensor mould with high-frequency electro-magnetic wave (5.8GHz) and integrated circuit. It gathers automatism, convenience, safety, saving-energy and practical functions. The wide detection field depends on detectors. It works by receiving human motion. When one enters the detection field, it can start the load at once and identify automatically day and night. Its installation is very convenient and its using is very wide. Detection is possible to go through doors, panes of glass or thin walls.

SPECIFICATION:

Power Sourcing: 220 -240V/AC

Detection Range: 360°/180°

Power Frequency: 50/60Hz

Detection Distance: wall: 5-15m (adjustable), ceiling: 2m, 5m, 8m (radius), adjustable

Ambient Light: 5lux, 30lux, 150lux, 2000lux (choice)

Transmission Power: <0.2mW

HF System: 5.8GHz CW radar, ISM band

Installing Height: wall: 1.5-3.5m, ceiling : 2-6m

Time Delay: 5s, 30s, 90s, 3min, 5min, 10min (choice)

Power Consumption: approx 0.9W

Rated Load: LED 1200W / INCADESCENT 300W

Detection Motion Speed: 0.6-1.5m/s

FUNCTION:

Can identify day and night: It can work in the daytime and at night when it is adjusted to the "000" position (LUX). It can work in the ambient light less than 5LUX when it is adjusted to the "001" position (LUX). As for the adjustment pattern, please refer to the testing pattern.

SENS adjustable: It can be adjusted according to using location; low sensitivity with 4m for detection distance; High sensitivity with 16m, it fits for large room.

Time-Delay is added continually: When it receives the second induction signals within the first induction, it will restart to time from the moment.

Time-Delay is adjustable. It can be set according to the consumer's desire. The minimum time is 5sec. The maximum is 10min.

NOTE: the high-frequency output of the HF sensor is <0.2Mw- that is just one 5000th of the transmission power of a mobile phone or the output of a microwave oven, the baby can't touch it

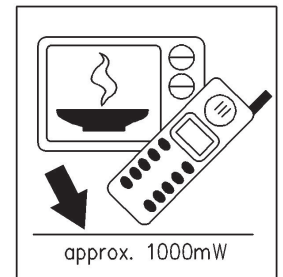
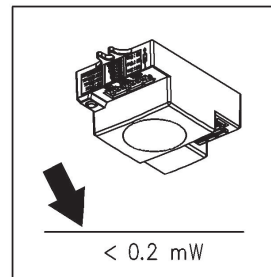

INSTALLATION: (see the diagram)

Switch off the power.

Fix the bottom on the selected position with the inflated screw through the screw holes in the side of the sensor.

Connecting the power and the load to sensor as per the connection-wire sketch diagram.

Switch on the power and test it

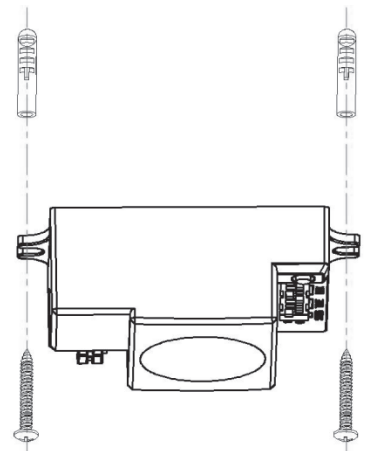

CONNECTION-WIRE DIAGRAM:

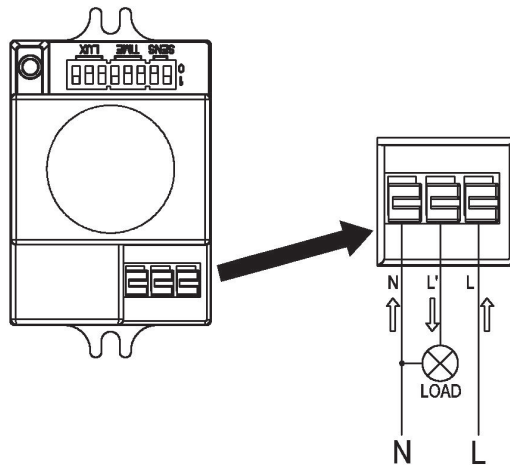

TEST:

Slide the SENS knob: The first knob on "1" position, the second knob on "0" position. Slide the TIME knob: The first knob and second knob on "0" position, the third knob on "1" position. Slide the LUX knob: first knob on "0" position, second and third knob on "0" position. When you switch on the power, the light will be on at once, and later will be off automatically. Then if the light receives induction signal, it can work normally

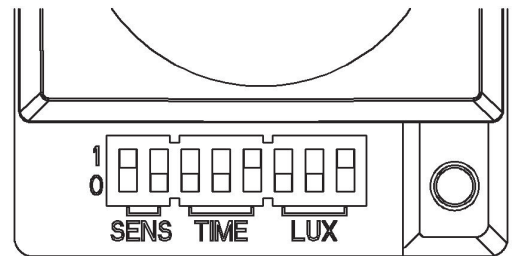

When the sensor receives the second induction signals within the first induction, it will restart to time from the moment.

Slide LUX knob, first and second knob on "0" position the third knob on "1" position. If the ambient light is less than 5LUX (darkness), the inductor load could work when it receives induction signal.

Note: when testing in daylight, please slide LUX knob to 2000lux, otherwise the sensor light could not work!

00 : 2m	001 : 5S	001 : 5 Lux
01 : 5m	010 : 30S	010 : 30Lux
10 : 8m	011 : 90S	100 : 150Lux
	110 : 3min	000 : 2000Lux
	100 : 5min	
	111 : 10min	

NOTES:

Electrician or experienced human can install it.

Can not be installed on the uneven and shaky surface

In front of the sensor there shouldn't be obstructive object affecting detection.

Avoid installing it near the metal and glass which may affect the sensor.

For your safety, please don't open the case if you find hitch after installation.

In order to avoid the unexpected damage of product, please add a safe device of current 6A when installing microwave sensor, for example, fuse, safe tube etc.

SOME PROBLEM AND SOLVED WAY:

The load don't work:

- Check the power and the load.
- Whether the indicator light is turned on after sensing? If yes, please check load.
- If the indicator light is not on after sensing, please check if the working light corresponds to the ambient light.
- Please check if the working voltage corresponds to the power source.

The sensitivity is poor:

- Please check if in front of the sensor there shouldn't be obstructive object that affect to receive the signals.
- Please check if the signal source is in the detection fields.
- Please check the installation height.

The sensor can't shut automatically the load:

- If there are continual signals in the detection fields.
- If the time delay is set to the longest.
- If the power corresponds to the instruction.