

Acti 9 Smartlink Modbus Communication System User Manual

04/2016

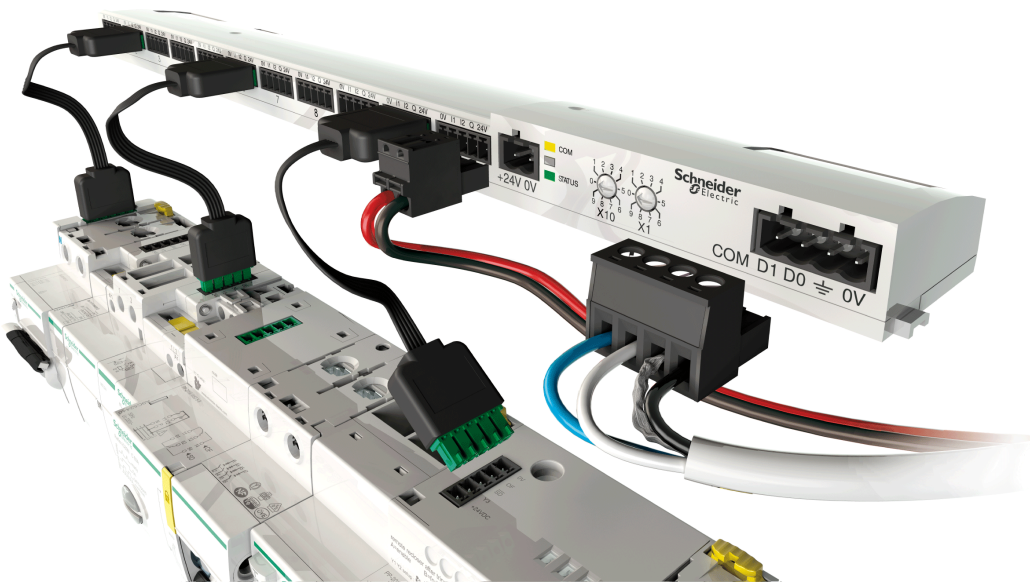

The information provided in this documentation contains general descriptions and/or technical characteristics of the performance of the products contained herein. This documentation is not intended as a substitute for and is not to be used for determining suitability or reliability of these products for specific user applications. It is the duty of any such user or integrator to perform the appropriate and complete risk analysis, evaluation and testing of the products with respect to the relevant specific application or use thereof. Neither Schneider Electric nor any of its affiliates or subsidiaries shall be responsible or liable for misuse of the information contained herein. If you have any suggestions for improvements or amendments or have found errors in this publication, please notify us.

No part of this document may be reproduced in any form or by any means, electronic or mechanical, including photocopying, without express written permission of Schneider Electric.

All pertinent state, regional, and local safety regulations must be observed when installing and using this product. For reasons of safety and to help ensure compliance with documented system data, only the manufacturer should perform repairs to components.

When devices are used for applications with technical safety requirements, the relevant instructions must be followed.

Failure to use Schneider Electric software or approved software with our hardware products may result in injury, harm, or improper operating results.

Failure to observe this information can result in injury or equipment damage.

© 2016 Schneider Electric. All rights reserved.

Table of Contents



	Safety Information	5
	About the Book	7
Chapter 1	Acti 9 Communication System	9
	Overview	9
Chapter 2	Architecture of Acti 9 Communication System	13
	Acti 9 Smartlink	14
	Acti 9 Communication System Pre-assembled Cables	15
	Acti 9 Devices with Ti24 Interface	17
	Acti 9 Devices without Ti24 Interface	18
	Devices out of the Acti 9 Range	19
Chapter 3	Technical Characteristics	21
	Technical Characteristics of the Acti 9 Smartlink	21
Chapter 4	Sizing the 24 Vdc Power Supply	25
	Definition of the 24 Vdc Power Supply	26
	Protection Against a 240 Vac Fault on the Acti 9 Smartlink Channels	28
	Electromagnetic Compatibility (EMC) Recommendations	29
Chapter 5	Installation	31
	Mounting	32
	Connection	37
Chapter 6	Connection of Input/Output Channels	43
	Acti 9 Devices with Ti24 Interface	44
	Meters	45
	Volt-Free Low Level Indication Contact	46
	Volt-Free Standard Indication Contact	47
	Surge Arresters	48
	Contactor and Relay (Not in the Acti 9 Range)	51
	Direct Output Connection	52
	Indirect Output Connection	53
	Generating Summary Data Using iOF+SD24 or OF+SD24	54
Chapter 7	Test	57
	Acti 9 Smart Test Software	57
Chapter 8	Setting Up Modbus Communication	59
	Modbus Master/Slave Principle	60
	Setup	63
	Resetting with Factory Parameters	64
	Acti 9 Smartlink Device Functions	65
	Modbus Functions	67
	Modbus Exception Codes	68
	Description of LEDs	69
Chapter 9	Tables of Modbus Registers	71
9.1	General Description of Modbus Tables	72
	Overview	73
	Modbus Table Format and Data Types	74
	Global Modbus Address Table	77
9.2	Summary and Detailed Modbus Tables	78
	System	79
	Summary of Channels 1 to 11	81
	Details of Channels 1 to 11	84
	Embedded Configuration Registers	90

9.3	Modbus Tables for Connected Products	91
	iOF+SD24 Indication Auxiliary	92
	OF+SD24 Indication Auxiliary	93
	iEM2000T, iEM3110, iEM3155, iEM3210, iEM3255, iEM3355 Meters or Meter with Pulse Output (Standard CEI 62053-31)	94
	iACT24 Auxiliary for iCT Contactor	95
	iATL24 Auxiliary for iTL Impulse Relay	96
	Contactor and Relay (Not in the Acti 9 Range)	97
	Acti 9 RCA iC60 Remote Control with Ti24 Interface	98
	Acti 9 Reflex iC60 Integrated Control Circuit Breaker With Ti24 Interface	99
Chapter 10	Integration of Acti 9 Smartlink in an EGX System	101
	Introduction to the EGX System	102
	Connection	103
	Configuration	105
	Control	109
	Monitoring	111
	Diagnostics	114
Appendices	115
Appendix A	Details of Modbus Functions	117
	Function 8: Modbus Diagnostics	118
	Function 43-14: Read Acti 9 Smartlink ID	119
	Function 43-15: Read Date and Time	121
	Function 43-16: Write Date and Time	122
	Function 100-4: Read n Non-Adjacent Words	123
Appendix B	Connecting Acti 9 Devices Directly to a PLC	125
	iACT24 Auxiliary for iCT Contactor	126
	iATL24 Auxiliary for iTL Impulse Relay	127
	iOF+SD24 Indication Auxiliary	128
	OF+SD24 Indication Auxiliary	129
	Acti 9 RCA iC60 Remote Control with Ti24 Interface	130
	Acti 9 Reflex iC60 Integrated Control Circuit Breaker With Ti24 Interface	131



Important Information

NOTICE

Read these instructions carefully, and look at the equipment to become familiar with the device before trying to install, operate, service, or maintain it. The following special messages may appear throughout this documentation or on the equipment to warn of potential hazards or to call attention to information that clarifies or simplifies a procedure.



The addition of this symbol to a “Danger” or “Warning” safety label indicates that an electrical hazard exists which will result in personal injury if the instructions are not followed.



This is the safety alert symbol. It is used to alert you to potential personal injury hazards. Obey all safety messages that follow this symbol to avoid possible injury or death.

DANGER

DANGER indicates a hazardous situation which, if not avoided, **will result in** death or serious injury.

WARNING

WARNING indicates a hazardous situation which, if not avoided, **could result in** death or serious injury.

CAUTION

CAUTION indicates a hazardous situation which, if not avoided, **could result in** minor or moderate injury.

NOTICE

NOTICE is used to address practices not related to physical injury.

PLEASE NOTE

Electrical equipment should be installed, operated, serviced, and maintained only by qualified personnel. No responsibility is assumed by Schneider Electric for any consequences arising out of the use of this material.

A qualified person is one who has skills and knowledge related to the construction and operation of electrical equipment and its installation, and has received safety training to recognize and avoid the hazards involved.

About the Book



At a Glance

Document Scope

The purpose of this manual is to provide users, installers and maintenance personnel with the technical information necessary to install and use the Acti 9 communication system.

Validity Note

The Acti 9 communication system can be easily integrated into any building management architecture. It combines command and control, metering and protection functions designed for energy efficiency solutions in any type of environment. Based on the Modbus protocol, the Acti 9 communication system allows switchboard data to be exchanged in real time with a supervision system or a PLC. This system's pre-wired connectors can save time and prevent wiring errors during installation.

Related Documents

Title of Documentation	Reference Number
Instruction Sheet for the iACT24 Auxiliary on the iCT Contactor (English, Dutch, French, German, Italian, Portuguese, Spanish, Chinese, Russian)	S1B33421
Instruction Sheet for the iATL24 Auxiliary on the iTL Remote Control Switch (English, Dutch, French, German, Italian, Portuguese, Spanish, Chinese, Russian)	S1B33422
Instruction Sheet for the Acti 9 Smartlink (English, Dutch, French, German, Italian, Portuguese, Spanish, Chinese, Russian)	S1B33423
Instruction Sheet for the RCA iC60 Remote Control (English, Dutch, French, German, Italian, Portuguese, Spanish, Chinese, Russian)	S1A4079001
Instruction Sheet for the Reflex iC60 Integrated Control Circuit Breaker (English, Dutch, French, German, Italian, Portuguese, Spanish, Chinese, Russian)	S1B8674701
Instruction Sheet for the iEM2000T Meter (English, Dutch, French, Finnish, German, Hungarian, Italian, Norwegian, Polish, Portuguese, Spanish, Swedish, Chinese, Russian)	S1A89364
Instruction Sheet for the iEM3100, iEM3110, iEM3115 Meters (English, French, German, Italian, Portuguese, Spanish, Chinese, Russian)	S1B46581
Instruction Sheet for the iEM3150, iEM3155 Meters (English, French, German, Italian, Portuguese, Spanish, Chinese, Russian)	S1B46583
Instruction Sheet for the iEM3200, iEM3210, iEM3215 Meters (English, French, German, Italian, Portuguese, Spanish, Chinese, Russian)	S1B46598
Instruction Sheet for the iEM3250, iEM3255 Meters (English, French, German, Italian, Portuguese, Spanish, Chinese, Russian)	S1B46602
Reference Manual for the RCA iC60 Remote Control for iC60 Circuit Breakers (English)	A9MA01EN

Title of Documentation	Reference Number
Reference Manual for the Reflex iC60 Integrated Control Circuit Breaker (English)	A9MA03EN
User Manual for the PowerLogic EGX300 Ethernet Gateway (English, French, German, Spanish)	63230-319-216
Technical Advice on the Acti 9 Smartlink Device (English)	CA908033EN
User Manual - Acti 9 Communication System Diagnostics (English)	DOCA0042EN
User Manual - Acti 9 Smart Test Software (English)	DOCA0029EN

You can download these technical publications and other technical information from our website at <http://download.schneider-electric.com>

Chapter 1

Acti 9 Communication System

Overview

Introduction

The Acti 9 communication system is used to connect final distribution boards to any supervision system. Modular equipment in the Acti 9 communication system is used to monitor, measure and control electrical distribution boards via a Modbus communication network.

The Acti 9 communication system concentrates the data from electrical distribution boards in real time, thus contributing to achieving energy efficiency targets.

The Acti 9 communication system collects data from any meter (including kilowatt-hour, water, air, gas or steam meters).

This system consists of:

- Acti 9 Smartlink and its test kit
- iOF+SD24 and OF+SD24 indication auxiliaries
- iACT24 and iATL24 auxiliaries for contactors and impulse relays in the Acti 9 range
- The Acti 9 RCA iC60 remote control module with Ti24 interface
- The Reflex iC60 integrated control circuit breaker with Ti24 interface
- iEM2000T, iEM3110, iEM3155, iEM3210, iEM3255, and iEM3355 meters
- Pre-wired cables

This system offers the following advantages and services:

- An automatic connection to the Modbus network
- No configuration operation required
- Calculation functions

The Acti 9 communication system is an open system:

- Acti 9 Smartlink can be used as a standard I/O distributed module.
- Acti 9 Smartlink is equipped with 11 24 Vdc channels. Each channel is represented by a Ti24 interface consisting of:
 - Two power supply terminals: 0 V and 24 Vdc
 - Two 24 Vdc logic inputs (I1 and I2)
 - One 24 Vdc logic output (Q)
- Each Ti24 interface is compatible with Miniconnect Phoenix standard connectors (at intervals of 3.81 mm) or equivalent.
- Acti 9 Smartlink is compatible with any type of counter (pulse output) compliant with standard IEC 62053-21 (minimum pulse 30 ms):
 - The pulse weight must be configured (written in a Modbus register).
 - Acti 9 Smartlink calculates consumption and flow.
- Acti 9 Smartlink is compatible with any type of device equipped with low level inputs and outputs (24 Vdc).

The Acti 9 communication system is simple and safe to use:

- The Acti 9 communication system pre-wired cables reduce complexity and wiring time by allowing connection on an Acti 9 Smartlink module of all the Acti 9 communication system components and 24 Vdc compatible products.
- All Acti 9 communication system functions can be created by sending messages (Modbus protocol) to Acti 9 Smartlink devices (Modbus slaves) that act on devices via Ti24 interfaces.

Acti 9 Communication System Block Diagram

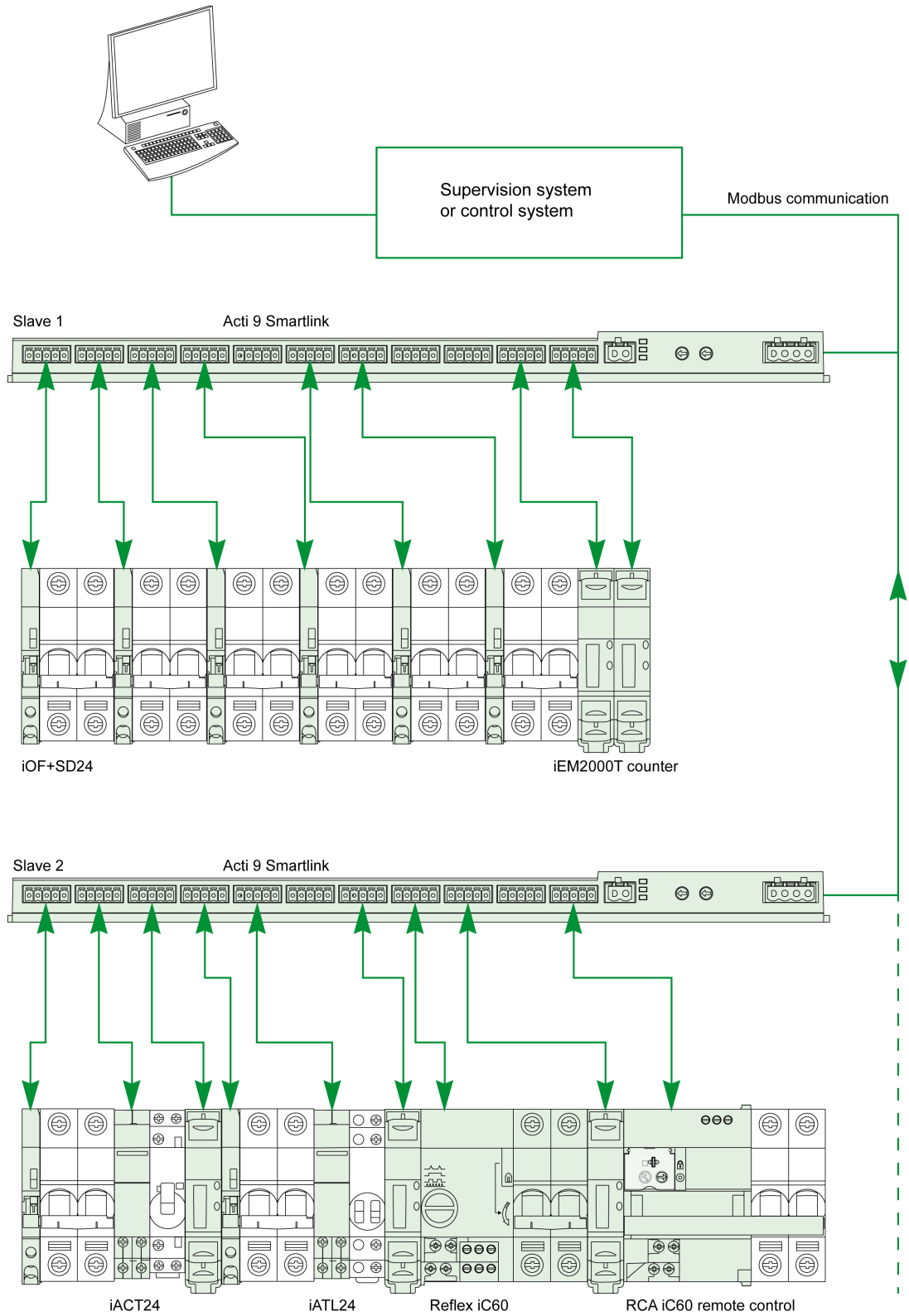

Integration of Acti 9 Smartlink (Modbus Protocol) in Schneider Electric Offers

Acti 9 Smartlink can connect via an RS 485 link to the following offers:

- PLCs
 - UNITY platform PLCs, version V3.0 or later: M340 and Premium
 - Small Twido and Zelio PLCs
- Building management system:
 - Struxureware Building Operation platform, version V1.2 or later
- Supervisors and human machine interfaces (HMIs):
 - Struxureware Power Monitoring ION-E electrical distribution supervisor, version V6.0 or later
 - EGX300 Web server, version V4.200 or later
 - Control and display of Magelis interfaces
- Controllers dedicated to energy management:
 - iRIO Xflow, version V3.3.1.0 or later

On installations where the connection is via Ethernet, compatibility is assured by means of EGX100 (Modbus RS 485 - Modbus Ethernet TCP/IP) and EGX300 gateways.

Integration of Acti 9 Smartlink in the iRIO Xflow, Struxureware Power Monitoring ION-E, Struxureware Building Operation, and EGX300 software product libraries allows:

- Automatic connection, without setting any parameters, when Acti 9 Smartlink is connected to one of these systems
- Access to predefined pages for viewing the Acti 9 Smartlink I/O in order to simplify system implementation and installation maintenance

For the UNITY platform, three function blocks (DFBs) have been created which can respectively, in a single operation:

- Manage automatic connection and set the energy meter parameters (pulse weight and initialization)
- Read the state of the I/O
- Obtain Acti 9 Smartlink statuses for diagnostic purposes

For installations using other communication systems (LON, KNX, BACnet, etc.), compatibility is assured by means of suitable gateways (for example: Modbus/KNX).

Chapter 2

Architecture of Acti 9 Communication System

What Is in This Chapter?

This chapter contains the following topics:

Topic	Page
Acti 9 Smartlink	14
Acti 9 Communication System Pre-assembled Cables	15
Acti 9 Devices with Ti24 Interface	17
Acti 9 Devices without Ti24 Interface	18
Devices out of the Acti 9 Range	19

Acti 9 Smartlink

Introduction

The Acti 9 Smartlink device has 11 channels (24 Vdc) and can be connected to devices in the Acti 9 range equipped with a Ti24 interface. Thanks to the Ti24 link, data can be transmitted from the Acti 9 Smartlink device to a PLC or a supervision system via a Modbus communication network.

The Acti 9 Smartlink device channels can also be used to transmit standardized I/O. The Acti 9 Smartlink device can also therefore communicate with devices (not in the Acti 9 range) with or without a Ti24 link.

Devices which can be connected to the Acti 9 Smartlink device include:

- Acti 9 products: control switch for iACT24 contactors and iATL24 impulse relays, iC60 iOF+SD24 indication auxiliary, C60 OF+SD24 indication auxiliary, RCA iC60 remote control with Ti24 interface, Reflex iC60 integrated control circuit breaker with Ti24 interface
- Meters: iEM2000T or other meters (Schneider Electric or other manufacturers) in compliance with IEC 62053-21 (minimum pulse 30 ms).
- Any product (not in the Acti 9 range) that has command and control information: two discrete 24 V outputs and one discrete 24 V inputs.

The Acti 9 Smartlink device is an intermediary between the supervisor and various electrical appliances. It can therefore be used to retrieve and process data received from devices and also control them. The functions available depend on the type of connected devices.

The Acti 9 Smartlink functions are described in detail (*see page 65*).

Description

The following figure shows the Acti 9 Smartlink device:

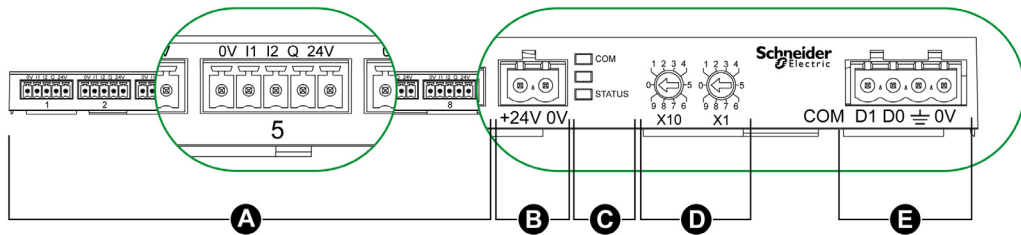

- A** 11 Digital I/O channels
- B** One 24 Vdc power supply connector
- C** LEDs that show the Acti 9 Smartlink device operating status
- D** Two thumbwheels for the device Modbus address
- E** One 4-pin Modbus connector

Acti 9 Communication System Pre-assembled Cables

Description

Acti 9 communication pre-assembled cables are a very quick way to connect all the Acti 9 communication system components and compatible products (24 Vdc) to the channels of an Acti 9 Smartlink module.

The pre-assembled cables are:

Product Reference	Description	Length (mm)
A9XCAS06	Set of six pre-assembled cables with two Ti24 connectors	100
A9XCAM06	Set of six pre-assembled cables with two Ti24 connectors	160
A9XCAH06	Set of six pre-assembled cables with two Ti24 connectors	450
A9XCAL06	Set of six pre-assembled cables with two Ti24 connectors	870
A9XCAU06	Set of six pre-assembled cables with one Ti24 connector	870
A9XCAC01	One pre-assembled cable with one Ti24 connector	4,000
A9XC2412	Set of 12 connectors with 5-pin spring	-

Each Ti24 interface (I/O channel) is compatible with Miniconnect Phoenix standard connectors (at intervals of 3.81 mm) or equivalent.

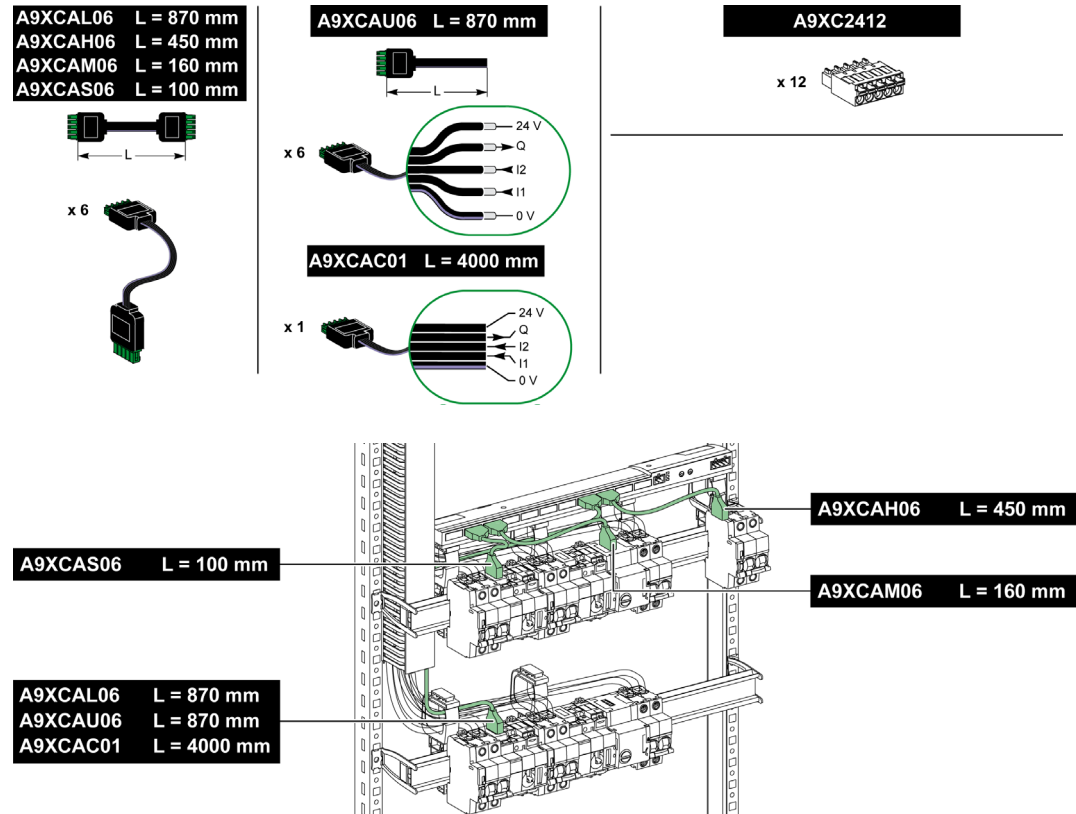



NOTE: The connectors in each pre-assembled cable have a flat surface where a self-adhesive label can be placed to identify the channel number used. Self-adhesive labels are not supplied by Schneider Electric.

Description of the Connector at the Ti24 Interface End	
Terminal	Description
24 V	24 V of the 24 Vdc power supply
Q	Control output
I2	Input number 2
I1	Input number 1
0 V	0 V of the 24 Vdc power supply

NOTE:

- Do not connect two wires in each of the Ti24 connector terminals (A9XC2412).
- Do not connect a wire with cable end in each of the Ti24 connector terminals.

The table shows the characteristics of cables that can be used with the A9XC2412 connector:

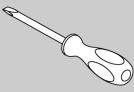
			
10 mm	0.5...1.5 mm ²		0.4 x 2.5

Acti 9 Devices with Ti24 Interface

Description

Devices that can be connected to the Acti 9 Smartlink are listed in the following table:

Device	Product Reference	Description
iACT24 auxiliary for iCT contactor	A9C15924	The iACT24 auxiliary: <ul style="list-style-type: none"> • Can be used to control a contactor (iCT) via its Y1, Y2 and Y3 inputs. The Y3 (24 Vdc) input can be controlled by one of the Acti 9 Smartlink device channels. • Is used to find out the contactor status (O/C status).
iATL24 auxiliary for iTL contactor	A9C15424	The iATL24 auxiliary: <ul style="list-style-type: none"> • Can be used to control an (iTL) impulse relay via its Y1, Y2 and Y3 inputs. The Y3 (24 Vdc) input can be controlled by one of the Acti 9 Smartlink device channels. • Is used to find out the impulse relay status (O/C status).
iOF+SD24 indication auxiliary for iC60, iC65 and iDPN circuit breakers	A9A26897	The iOF+SD24 indication auxiliary is used to find out the status of a iC60, iC65 (OF and \overline{SD} states) and iDPN circuit breaker (sold in China).
OF+SD24 indication auxiliary for C60, C120, C60H-DC and iDPN circuit breakers	A9N26899	The OF+SD24 indication auxiliary is used to find out the status of a C60, C120, C60H-DC (OF and \overline{SD}) and iDPN circuit breaker (sold in every country except China).
Acti 9 RCA iC60 remote control with Ti24 interface	A9C7012•	The Acti 9 RCA iC60 remote control: <ul style="list-style-type: none"> • Should have a Ti24 interface (with product references A9C70122 and A9C70124). • Can be used to control an iC60 circuit breaker via input Y3 of its Ti24 interface. Input Y3 (24 V DC) can be controlled by one of the device channels Acti 9 Smartlink. • Can be used to find out the OF and \overline{SD} status of the circuit breaker associated with the RCA iC60 remote control.
Acti 9 Reflex iC60 integrated control circuit breaker with Ti24 interface	A9C6****	The Acti 9 Reflex iC60 integrated control circuit breaker: <ul style="list-style-type: none"> • Should have a Ti24 interface (with product references A9C6****). • Can allow the device to be controlled via input Y3 of its Ti24 interface. The Y3 (24 Vdc) input can be controlled by one of the Acti 9 Smartlink channels. • Can be used to communicate its O/C and auto/OFF status.

NOTE: All the devices in the preceding table can be connected to channel N (1 = N = 11) of an Acti 9 Smartlink module with A9XCAS06 pre-wired cable (or A9XCAM06 or A9XCAH06).

Acti 9 Devices without Ti24 Interface

Description

Devices that can be connected to the Acti 9 Smartlink are listed in the following table:

Designation	Product Reference	Description
iEM2000T	A9MEM2000T	Single-phase energy meter without display
iEM3110	A9MEM3110	Three-phase energy meter with display
iEM3155	A9MEM3155	Three-phase energy meter with display
iEM3210	A9MEM3210	Three-phase energy meter with display
iEM3255	A9MEM3255	Three-phase energy meter with display
iPRD (Type 2)	A9L***1	Withdrawable surge arresters with remote indication contact iPRD65r/iPRD40r/iPRD20r/iPRD8r
iPRD 40r PV (Type 2)	A9L40271 A9L40281	Withdrawable surge arresters with remote indication contact
iPRF1 12.5r (Type 1 + Type 2; Type B+C)	A9L16632 A9L16633 A9L16634	Monobloc surge arresters with remote indication contact
PRD1 25r (Type 1 + Type 2)	16329 16330 16331 16332	Withdrawable surge arresters with remote indication contact
PRD1 Master (Type 1)	16360 16361 16362 16363	Withdrawable surge arresters with remote indication contact
iQuick PRD (Type 2)	A9L16292 A9L16293 A9L16294 A9L16295 A9L16296 A9L16297 A9L16298 A9L16299 A9L16300	Withdrawable surge arresters with integrated backup MCB and remote indication contact

NOTE: The connection of these devices can be done with an A9XCAU06 or A9XCAC01 pre-wired cable: molded connector (at Smartlink end), and with five wires (at device end).

The table describes the products that need a low level interface relay to connect to Acti 9 Smartlink:

Designation	Product Reference	Description
IH, IHP	see catalog	Timer switches with RBN type low level relays or equivalent
IC	see catalog	Light sensitive switches with RBN type low level relays or equivalent
TH, THP	see catalog	Thermostats with RBN type low level relays or equivalent

Devices out of the Acti 9 Range

Description

Devices that can be connected to the Acti 9 Smartlink are:

- Meter with a pulse output and compliant with standard IEC 62053-31
- Volt-Free Low Level Indication Contact
- Volt-Free Standard Indication Contact
- Contactor and Relay
- Indication device or PLC input can be directly connected to the output (Q) of Acti 9 Smartlink channel. The connected device should have the following characteristics:
 - To be powered with 24 Vdc
 - The consumption must be less than 100 mA
- Any device (for example: motor) that needs a command circuit of more than 100 mA can be controlled by the output (Q) of a channel of Acti 9 Smartlink. The electrical diagram must be indirect between Acti 9 Smartlink and this device: a low level relay must be installed between the command of this device and Acti 9 Smartlink.

NOTE: The connection of these devices can be done with an A9XCAU06 or A9XCAC01 pre-wired cable: molded connector (at Smartlink end), and with five wires (at device end).

Chapter 3

Technical Characteristics

Technical Characteristics of the Acti 9 Smartlink

General Characteristics

Characteristic		Value
Product marking		CE, GOST
Temperature	Operation (horizontal)	-25...+60°C
	Operation (vertical)	-25...+50°C
	Storage	-40...+85°C
Tropicalization		Execution 2 (relative humidity of 93% at 40 °C)
Resistance to voltage dips		10 ms, class 3 according to IEC 61000-4-29
Degree of protection		IP 20
Level of pollution		3
Overvoltage category		OVC II
Conforming to SELV specifications		Yes
Altitude	Operation	0...2,000 m
	Storage	0...3,000 m
Immunity to vibration	IEC 60068-2-6	1 g/± 3.5 mm, 5...300 Hz, 10 cycles
Immunity to mechanical shock		15 g/11 ms
Immunity to electrostatic discharge	IEC 61000-4-2	Air: 8 kV
		Contact: 4 kV
Immunity to radiated electromagnetic interference	IEC 61000-4-3	10 V/m – 80 MHz to 3 GHz
Immunity to fast transients	IEC 61000-4-4	1 kV for the I/O and Modbus communication. 2 kV for the 24 Vdc - 5 kHz - 100 kHz power supply
Immunity to conducted magnetic fields	IEC 61000-4-6	10 V from 150 kHz to 80 MHz
Immunity to magnetic fields at line frequency	IEC 61000-4-8	30 A/m continuous 100 A/m pulse
Resistance to corrosive atmospheres	IEC 60721-3-3	Level 3C2 on H ² S/SO ² /NO ² /Cl ²
Fire withstand	For live parts	30 s at 960 °C. IEC 60695-2-10 and IEC 60695-2-11
	For other parts	30 s at 650 °C. IEC 60695-2-10 and IEC 60695-2-11
Salt mist	IEC 60068-2-52	Severity 2
Environment		Conforms to RoHS directives
Installation position		Horizontal or vertical
Mean time between failures		More than 1 M hours

Mechanical Characteristics

Characteristic		Value
Dimensions	Length	359 mm
	Height	22.5 mm
	Depth	42 mm
Weight		195 g

Communication Module

Characteristic		Value
Type of interface module		Modbus, RTU, RS485 serial connection
Transmission	Transfer rate	9600...19 200 Baud
	Medium	Double shielded twisted pair Impedance 120 Ω
Structure	Type	Modbus
	Method	Master/slave
Device type		Slave
Turnaround time		10 ms (approx.)
Max. length of Modbus line		1,000 m
Type of bus connector		4-pin connector
Power supply	Nominal	Non-isolated 24 Vdc with protection against negative voltages up to -28.8 Vdc
	Voltage limits	19.2... 28.8 Vdc with ripple
	Current consumption, no-load	35 mA
	Maximum input intensity	1.5 A
	Maximum current inrush	3 A (limited internally)
Isolation	Between the Modbus serial connection and 24 Vdc Ti24 I/O interfaces	1,500 V RMS for 1 minute
Number of digital I/O channels		11

Integrated Functions

Characteristic		Value
Counter	Number of counters	Up to 22 (22 inputs)
	Maximum frequency	16.667 Hz, IEC 62053-31
Period stored in backup memory		10 years

Inputs

Characteristic		Value
Number of logic inputs		22 (2 per channel)
Rated input voltage		24 Vdc
Input type		Current sink, type 1 IEC 61131-2
Weight (0 V)		1 for 2 inputs (1 per channel)
Input voltage limits		19.2...28.8 Vdc
Rated input current		2.5 mA
Maximum input current		5 mA
Filter time		2 ms
Acquisition time		10 ms
Isolation		No isolation between the Ti24 interfaces
Negative voltage protection		Yes
Maximum length of cables and cordsets		500 m (conductor c.s.a. of at least 0.5 mm ²)

Outputs

Characteristic		Value
Number of logic outputs		11 (1 per channel)
Logic output		Current source, 24 Vdc 0.1 A IEC 61131-2
Weight (0 V)		1
Rated output voltage	Voltage	24 Vdc
	Maximum current	100 mA
Filter time		1 ms
Voltage drop (voltage at state 1)		1 V max.
Maximum current inrush		500 mA
Leakage current		0.1 mA
Overvoltage protection		33 Vdc
Short-circuit protection		Yes
Overload protection		Yes
Current limiting		Yes
Maximum length of cables and cordsets		500 m (conductor c.s.a. of at least 0.5 mm ²)

iACT24

Characteristic		Value
Control voltage (Ue)		230 Vac, +10 %, -15 % (Y2) 24 Vdc, ± 20 % (Y3)
Control voltage frequency		50/60 Hz
Insulation voltage (Ui)		250 Vac
Rated impulse withstand voltage (Uimp)		8 kV (OVC IV)
Level of pollution		3
Degree of protection		IP20B device only IP40 device in modular enclosure
Width in 9 mm modules)		2
Auxiliary contact (O/C) Ti24		24 Vdc protected output, min. 2 mA, max. 100 mA
Contact		1 O/C operating category AC 14
Temperature	Operation	-25 ... 60 °C
	Storage	-40 ... +80°C
Consumption		< 1 W
Standard		IEC/EN 60947-5-1

iATL24

Characteristic		Value
Control voltage (Ue)		230 Vac, +10 %, -15 % (Y2) 24 Vdc, \pm 20 % (Y3)
Control voltage frequency		50/60 Hz
Insulation voltage (Ui)		250 Vac
Rated impulse withstand voltage (Uimp)		8 kV (OVC IV)
Level of pollution		3
Degree of protection		IP20B device only IP40 device in modular enclosure
Width in 9 mm modules)		2
Auxiliary contact (O/C) Ti24		24 Vdc protected output, min. 2 mA, max. 100 mA
Contact		1 O/C operating category AC 14
Temperature	Operation	-25 ... 60 °C
	Storage	-40 ... +80°C
Consumption		< 1 W
Standard		IEC/EN 60947-5-1

Chapter 4

Sizing the 24 Vdc Power Supply

What Is in This Chapter?

This chapter contains the following topics:

Topic	Page
Definition of the 24 Vdc Power Supply	26
Protection Against a 240 Vac Fault on the Acti 9 Smartlink Channels	28
Electromagnetic Compatibility (EMC) Recommendations	29

Definition of the 24 Vdc Power Supply

Safety Information

DANGER

RISK OF ELECTROCUTION

Isolate the Acti 9 Smartlink power terminals from the power terminals connected to the Modbus network line.

Failure to follow these instructions will result in death or serious injury.

Example: The 0 V and the 24 V of a 24 Vdc power supply connected to the TRV00210 ULP communication module must be isolated from the **0 V** or **+24 V** terminals of the 24 Vdc power supply for the Acti 9 Smartlink device.

General Characteristics

Acti 9 Smartlink device consumption:

Status	Consumption
Device with no load	35 mA
Device under load	1.5 A maximum

Products in the Acti 9 Range

If products connected to the channels (Ti24 interfaces) of an Acti 9 Smartlink device are in the Acti 9 range, the consumption of a channel output is the same as the consumption of an input because the output is connected to the input. All that needs to be done is to add up the consumption of 3 input currents per channel.

Example: Assuming that the input current is less than 5 mA, the consumption of an Acti 9 Smartlink device is as follows:

$$\text{No-load consumption} + \text{number of outputs} \times 3 \text{ input currents} = 35 \text{ mA} + 11 \times (3 \times 5 \text{ mA}) = 200 \text{ mA}$$

Products that can be Controlled by a Channel

If products connected to the channels (Ti24 interfaces) of an Acti 9 Smartlink device are in a different range, the maximum consumption of a device channel is 110 mA. The output for each channel supplies 100 mA and the inputs can consume up to 5 mA each.

Example: Assuming that the consumption of one channel is 110 mA, the consumption of one Acti 9 Smartlink device is as follows:

$$\text{No-load consumption} + \text{number of outputs} \times \text{consumption per channel} = 35 \text{ mA} + 11 \times (110 \text{ mA}) = 1.3 \text{ A}$$

Selection of the Acti 9 Smartlink 24 Vdc Power Supply

The 24 Vdc power supply must correspond to the following criteria:

- It must be local to the electrical cabinet.
- It must be different from the Modbus network 24 Vdc power supply so as to maintain galvanic isolation between the Modbus network (common to several electrical cabinets) and the 24 Vdc I/O.
- It must be Safety Extra Low Voltage (SELV) type.
- Galvanic isolation between the power supply input (AC voltage) and the power supply output (DC voltage) must be at least 4 kVac at 50 Hz.
- The rated AC voltage of the power supply input must be 240 Vac +15/-20%.
- This power supply can be used to supply other products inside the electrical cabinet provided that these products are double insulated or with reinforced insulation so as to preserve the power supply's SELV quality.

Phaseo ABL8MEM240xx (OVC II) or ABL7RM24025 (OVC II) modular power supplies and their accessories comply with the earlier recommendations in this topic. These accessories provide the redundancy and backup power supply functions and can eliminate micro-cuts on the line.

The upstream and downstream protection functions of the Phaseo power supply must be installed as indicated in their respective manuals.

NOTE: OVC indicates the overvoltage category.

If overvoltage category IV or III is needed in the installation, we recommend using:

- Either power supplies (limited to 1 A) in the ULP (Universal Logic Plug) system with product references 54440 to 54445. See the User's Manual, ULP Connection System, product reference TRV99100
- Or use the Phaseo power supply recommended earlier in this topic, protecting it with an isolating transformer from the Phaseo Optimum (ABL6TS) range or the Universal (ABT7PDU) range.

NOTE: For each of these solutions, you should refer to the respective manuals.

Protection Against a 240 Vac Fault on the Acti 9 Smartlink Device 24 Vdc Input

In case a 240 Vac power supply is accidentally connected to the 24 Vdc input on the Acti 9 Smartlink power supply, fuse protection is provided.

Protection Against a 240 Vac Fault on the Acti 9 Smartlink Channels

Protection Against a 240 Vac Fault on the Acti 9 Smartlink Channels

In the event of a wiring error or electrical fault, the 240 Vac voltage may be present on the Acti 9 Smartlink device channels: the neutral or phase (240 Vac) can be in contact with the Ti24 interfaces or the 24 Vdc power supply.

The insulation inside the Acti 9 Smartlink device prevents propagation of this dangerous voltage (240 Vac) over the Modbus network.

The protection function inside the Acti 9 Smartlink device eliminates the risk of fire inside the Acti 9 Smartlink device.

These two protection functions (internal insulation and internal protection) cannot prevent wiring errors or electrical faults. A risk of dangerous voltage remains on the Acti 9 Smartlink device channels.

DANGER

HAZARD OF ELECTRIC SHOCK, EXPLOSION, OR ARC FLASH

- Implement a TT or TN-S earthing system.
- Connect the SELV power supply 0 Vdc to the protective earth to make it a PELV (Protective Extra Low Voltage) power supply. The upstream residual current protection must be type A.

Failure to follow these instructions will result in death or serious injury.

NOTE: In the majority of cases, the presence of a PELV means an upstream residual current protection can trip, thus protecting people and property.

DANGER

ACCIDENTAL EQUIPMENT BEHAVIOR

- Connect the 0 Vdc of the SELV power supply to the protective earth at a single point to avoid any stray currents (50 Hz, harmonics, or transient currents) circulating across the 0 Vdc.
- Check that products supplied by this power supply are not already connecting the 0 Vdc to the protective earth.

Failure to follow these instructions will result in death or serious injury.

NOTICE

RISK OF DAMAGING THE ACTI 9 SMARTLINK DEVICE

- Connect the 0 Vdc of the SELV power supply to the protective earth at a single point to avoid any stray currents (50 Hz, harmonics, or transient currents) circulating across the 0 Vdc.
- Check that products supplied by this power supply are not already connecting the 0 Vdc to the protective earth.

Failure to follow these instructions can result in equipment damage.

Electromagnetic Compatibility (EMC) Recommendations

Electromagnetic Compatibility (EMC) Recommendations

A star 24 Vdc distribution is preferable to a serial 24 Vdc distribution because star 24 Vdc distribution can minimize the wiring impedance.

If serial distribution is used, it is advisable to wire two serial loopback wires (see the two blue wires in the following drawing) in order to minimize impedance.

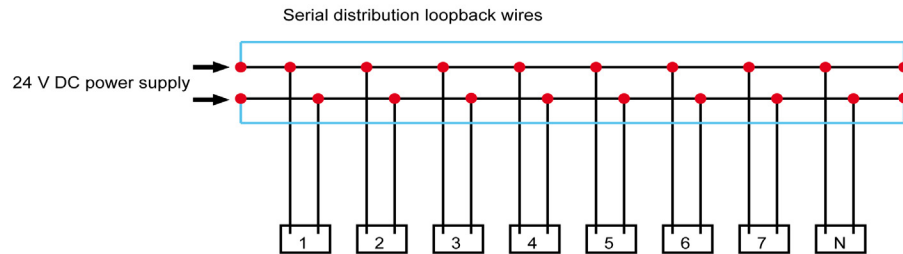

In a poor-quality electrical distribution network, it is advisable to use a Phaseo power supply from the Universal range (ABL8MEM240xx (OVC II) or ABL7RM24025 (OVC II)) which can withstand up to 500 Vac incoming and also offers galvanic insulation between the power supply AC input and the power supply DC output of 4 kVac at 50 Hz.

It is advisable to comply with the segregation rules between low level signals (24 Vdc) and power conductors, see:

- www.electrical-installation.org see the "ElectroMagnetic Compatibility (EMC)" part, "Wiring recommendations" section (information only available in English).
- Electrical Installation Guide in pdf format: Document No. EIGED306001EN.

Chapter 5

Installation

What Is in This Chapter?

This chapter contains the following topics:

Topic	Page
Mounting	32
Connection	37

Mounting

Introduction

The Acti 9 Smartlink device can be mounted on:

- DIN rail
- Multiclip 80
- Multiclip 200
- Mounting brackets

Acti 9 Smartlink can be installed horizontally or vertically:

- In a horizontal mounting, Acti 9 Smartlink is clipped onto DIN rails with fixing centers of 150 mm or more.
- Wall-mounted and floor-standing enclosures must be at least 24 modules wide (18 mm x 24 = 432 mm).
- The distance between the DIN rail and the back of the wall-mounted or floor-standing enclosure must be at least 50 mm.

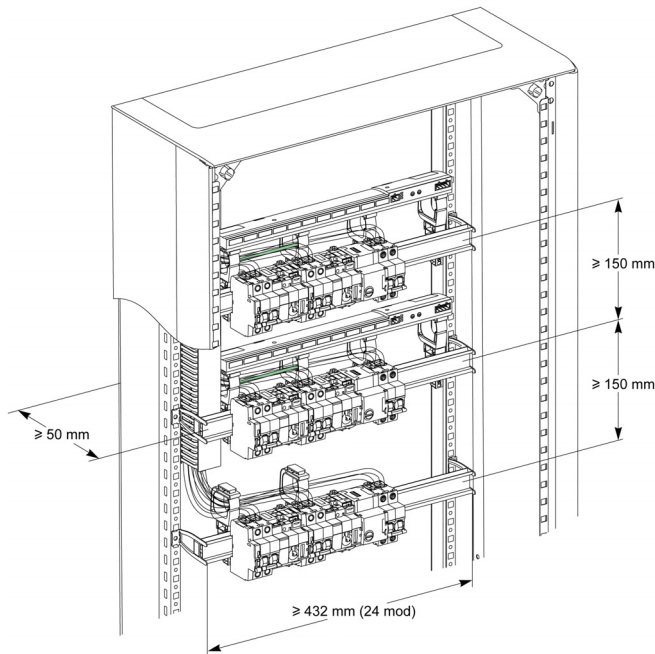

The ambient operating temperature is:

- Horizontal mounting: - 25° to +60°C
- Vertical mounting: - 25° to +50°C

Mounting Components

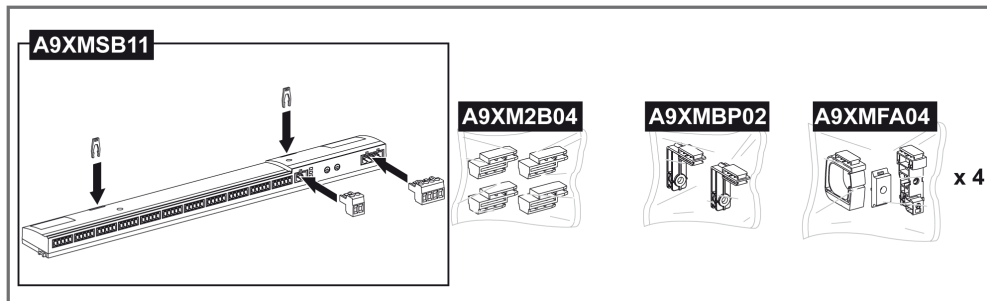

Product Reference	Description
A9XMSB11	Acti 9 Smartlink
A9XMFA04	Set of bracelets, adaptors and feet for DIN rail mounting
A9XM2B04	Spacers for Multiclip 200 mounting
A9XMBP02	Mounting brackets kit

DIN Rail Mounting

The side of the foot (**A** or **B** in the following drawing) used to mount the system on the DIN rail depends on the type of rail (aluminum or iron).

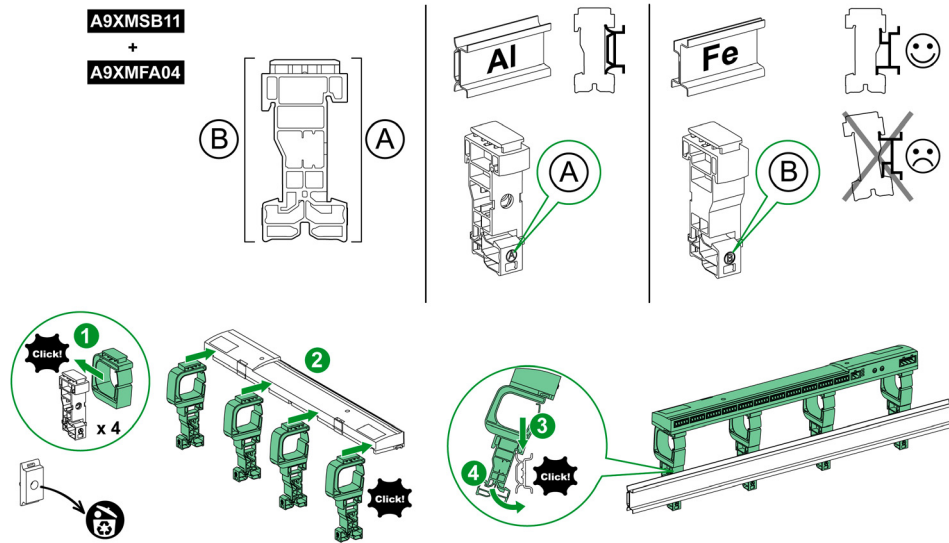

The table describes the procedure for mounting the Acti 9 Smartlink device on a DIN rail:

Step	Action
1	Clip one bracelet onto one foot according to the type of rail. Repeat this step three times.
2	Clip the Acti 9 Smartlink device on top of the bracelets.
3	Place the top of the foot at an angle against the top lip of the rail.
4	Clip the bottom of the foot into place.
5	Repeat steps 3 and 4 for each of the other three feet.

Simple DIN Rail Mounting

To mount the system on a simple DIN rail (iron), use side **A** of the foot.

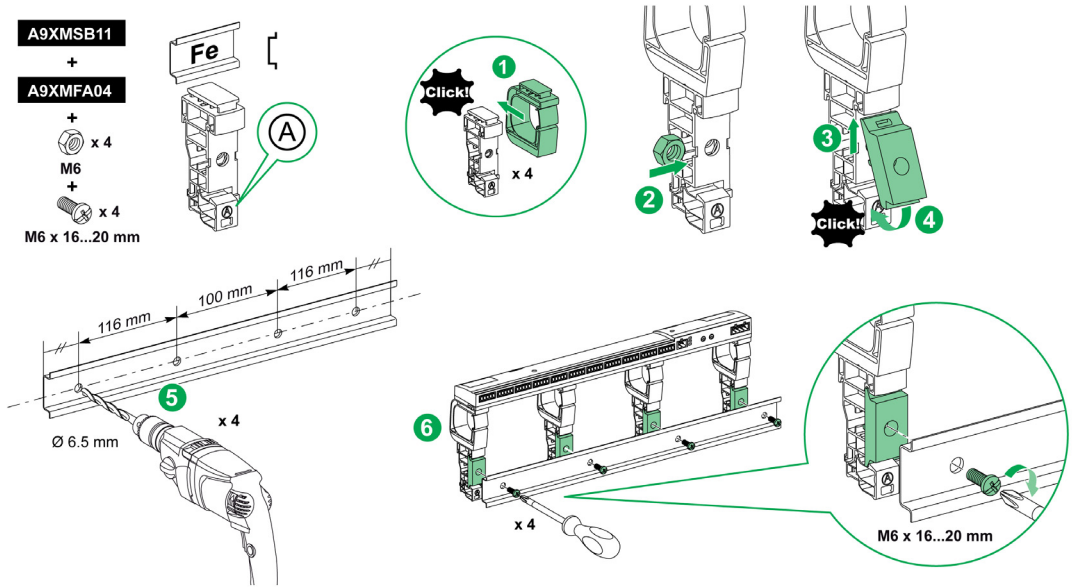

The table describes the procedure for mounting the Acti 9 Smartlink device on a simple DIN rail:

Step	Action
1	Clip one bracelet onto side A of a foot. Repeat this step three times.
2	Place one M6 nut inside a foot. Repeat this step three times.
3	Position the top of an adaptor diagonally at the front of a foot.
4	Clip the bottom of the adaptor into place. Repeat steps 3 and 4 three times.
5	Drill the rail making sure that the drill hole diameters and positioning dimensions are correct, as shown in the preceding graphic.
6	Screw the feet onto the rail.

Mounting on Multiclip 80

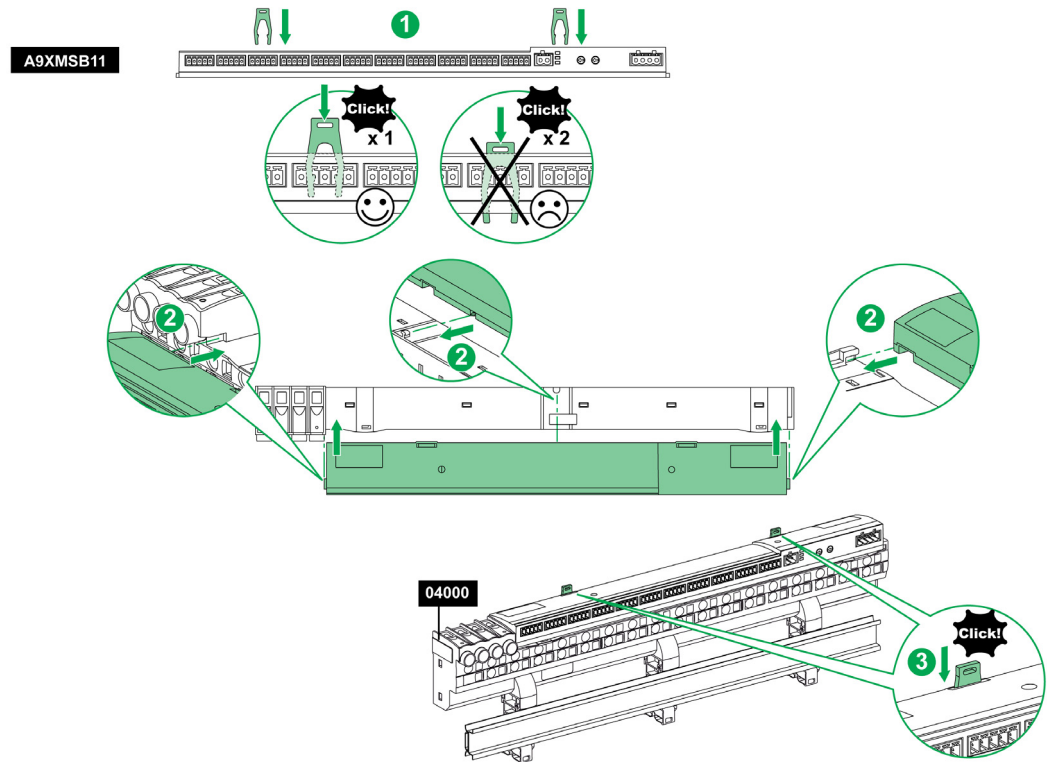

The table describes the procedure for mounting the Acti 9 Smartlink device on Multiclip 80.

Step	Action
1	Position the two clips in the notches on the Acti 9 Smartlink device.
2	Slide the Acti 9 Smartlink device front first onto the Multiclip 80 until fully inserted.
3	Push down the two clips until they click into place.

Mounting on Multiclip 200

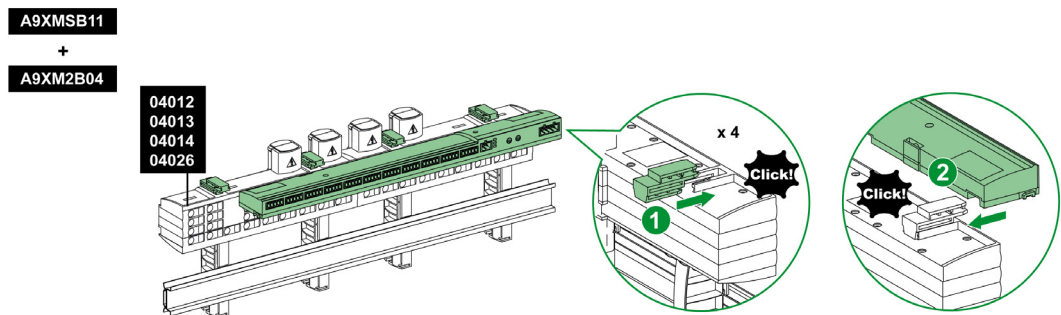

The table describes the procedure for mounting the Acti 9 Smartlink device on Multiclip 200.

Step	Action
1	Slide the four spacers from the back into the notches on top of the Multiclip 200.
2	Slide the Acti 9 Smartlink device front first onto the spacers, until it clicks into place.

Mounting with Brackets

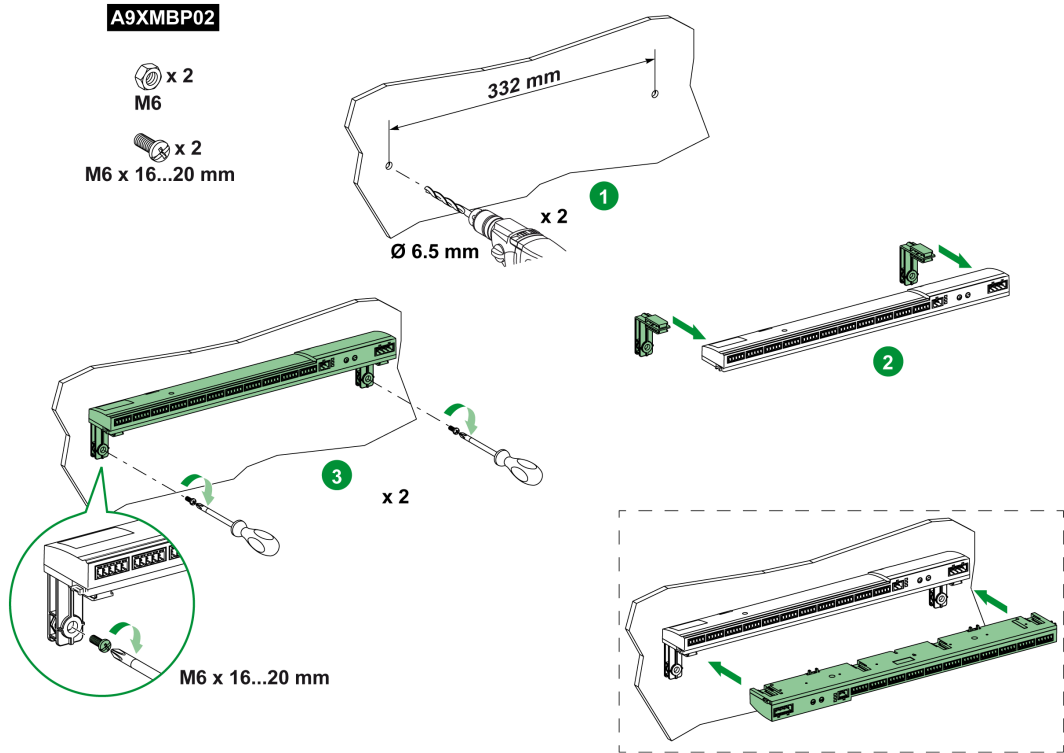

The table describes the procedure for mounting the Acti 9 Smartlink device with brackets.

Step	Action
1	Drill the plate of the cubicle making sure that the drill hole diameters and positioning dimensions are correct, as shown in the preceding graphic.
2	Slide the 2 brackets, from the back of the Acti 9 Smartlink device, into the notches on the bottom of the Acti 9 Smartlink device until they click into place.
3	Screw the brackets onto the plate.

Connection

Safety Instructions

DANGER

RISK OF ELECTRIC SHOCK, EXPLOSION, OR ARC FLASH

- Wear suitable personal protective equipment and follow the currently applicable electrical safety instructions.
- This equipment may only be installed by qualified electricians who have read all the relevant information.
- NEVER work alone.
- Before performing visual inspections, tests, or maintenance on this equipment, disconnect all sources of electric power. Assume that all circuits are live until they have been completely de-energized, tested and tagged. Pay particular attention to the design of the power system. Consider all power supply sources, particularly the potential for backfeed.
- Before closing protective covers and doors, carefully inspect the work area to ensure that no tools or objects have been left inside the equipment.
- Take care when removing or replacing panels. Take special care to ensure that they do not come into contact with live busbars. To minimize the risk of injuries, do not tamper with the panels.
- The successful operation of this equipment depends upon proper handling, installation, and operation. Failure to follow basic installation procedures can lead to personal injury as well as damage to electrical equipment or other property.
- NEVER shunt an external fuse/circuit breaker.
- This equipment must be installed inside a suitable electrical cabinet.

Failure to follow these instructions will result in death or serious injury.

DANGER

RISK OF ELECTROCUTION

Isolate the Acti 9 Smartlink power terminals from the power terminals connected to the Modbus network line.

Failure to follow these instructions will result in death or serious injury.

Connecting the Power Supply Connector

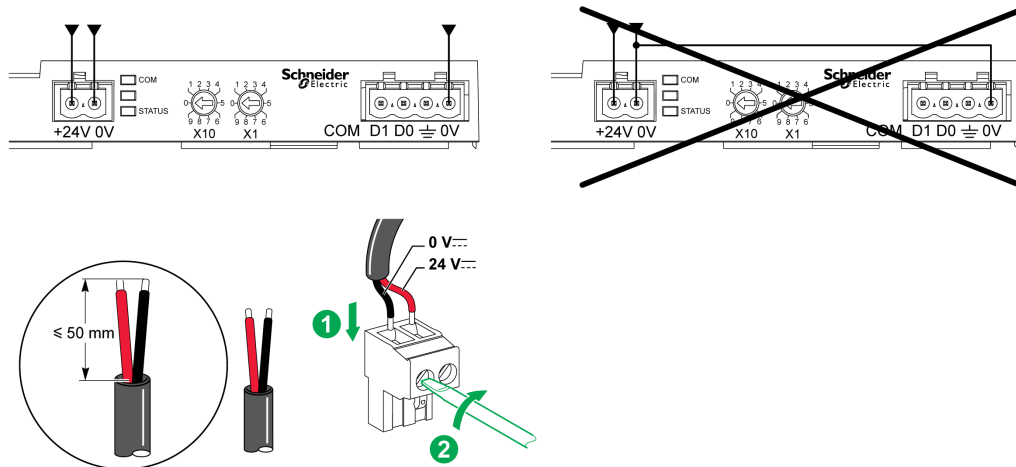

The table describes the procedure for connecting the power supply connector:

Step	Action
1	Insert both stripped power supply wires in the connector.
2	Fix the wires in place using the connector tightening screws.

The table gives the characteristics of cables that can be used to connect the 24 Vdc power supply:

7 mm	0.2...1.5 mm ²	0.8 N.m	0.6 x 3.5

Connecting the Modbus Connector

The Schneider Electric communication cables to be used are:

Product Reference	Description	Length (m)
50965	RS 485 double shielded twisted pair cable for Modbus serial link (supplied without connector)	60

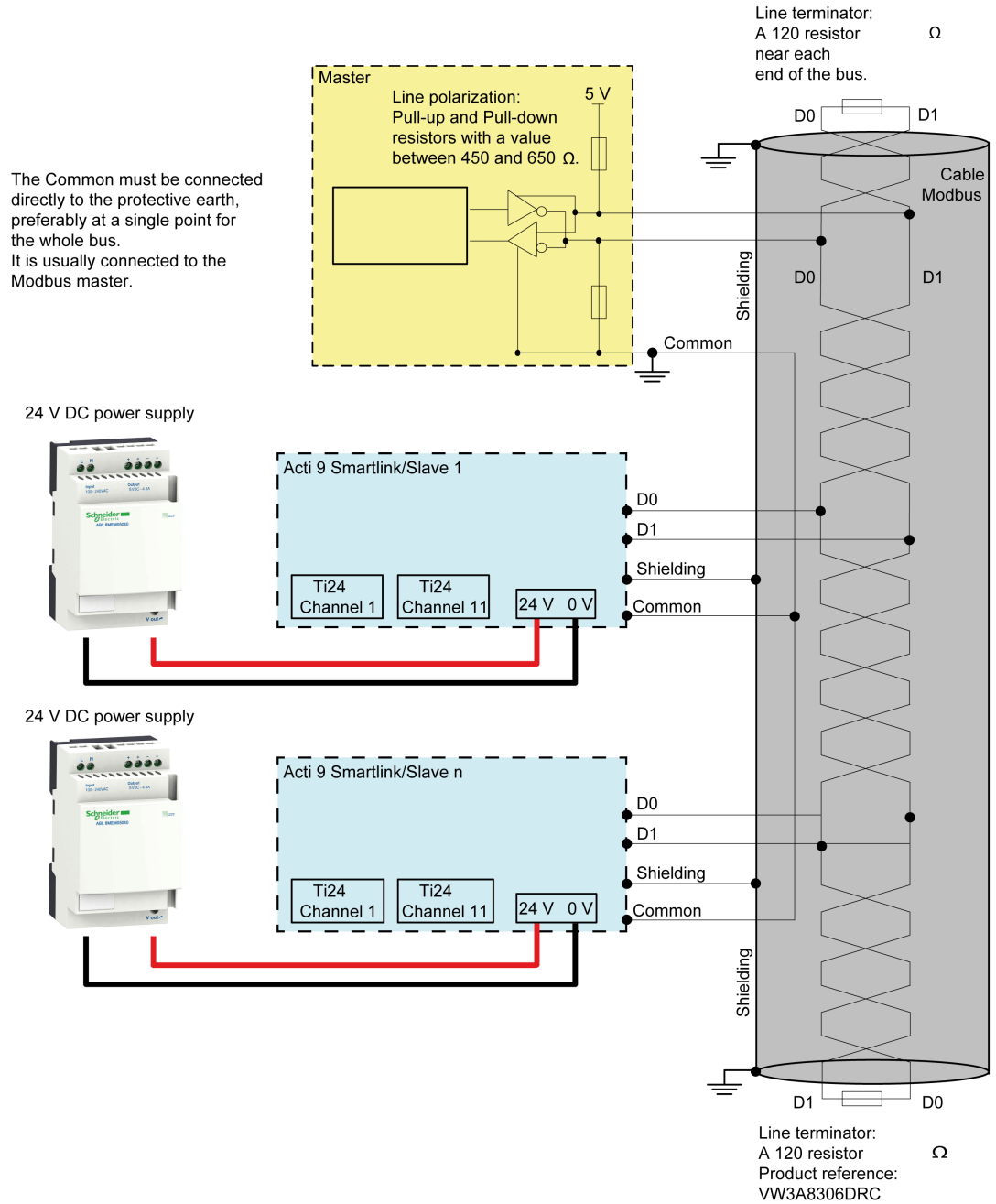

NOTE:

- It is possible to use a common 24 Vdc power-supply for several Acti 9 Smartlink devices if installed in the same switchboard.

NOTICE

HAZARD OF NON-OPERATION OF MODBUS NETWORK
 Comply with the wiring and connection rules described later in this topic to create a working Modbus network.
Failure to follow these instructions can result in equipment damage.

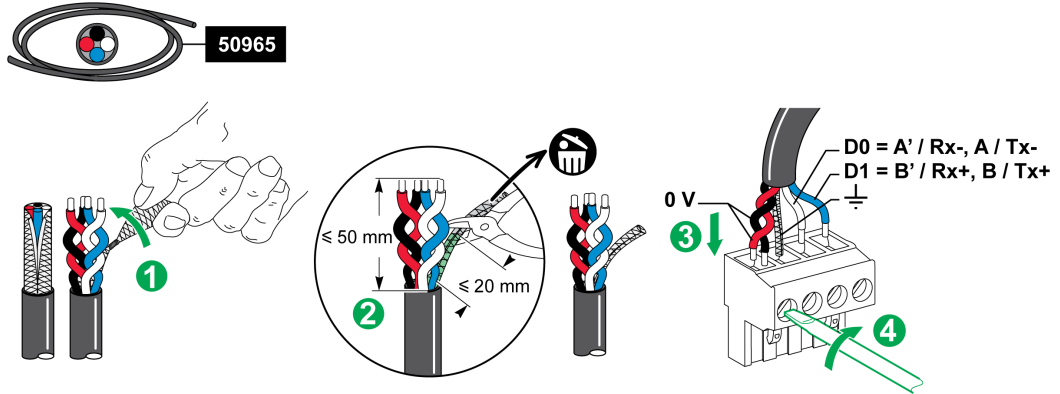

The table describes the procedure for connecting the Modbus connector:

Step	Action
1	Coil up the Modbus communication cable shielding.
2	Cut the shielding 20 mm from the sheath.
3	Insert the stripped wires in the connector terminals as shown in the preceding graphic.
4	Fix the wires in place using the connector tightening screw.

The table gives the characteristics of cables that can be used to connect the Modbus connector:

7 mm	0.2...1.5 mm ²			0.8 N.m	0.6 x 3.5

Checking the Modbus Serial Link

The table gives the characteristics of the RS 485 link that need to be checked during installation:

Designation	Description
Shielding connection	Each Modbus serial link must have shielding connected at one point to an earthed link.
Bus polarization	<ul style="list-style-type: none"> • Pull-up resistor connected to the 5 V: 450...650 Ohm • Pull-down resistor connected to ground (Modbus 0 V): 450...650 Ohm <p>NOTE: This polarization is recommended for the master.</p>
Line terminator	<p>2 Modbus line terminators (120 Ohm + 1 nF), reference VW3A8306DRC.</p> <p>The Modbus cable communication pair has characteristic impedance of 120 Ohm. The Modbus cable must therefore have a Modbus line terminator with 120 Ohm impedance at each end.</p> <p>The Modbus master is at one end of the Modbus cable and usually has a switchable terminal impedance. At the other end of the Modbus cable, a Modbus line terminator with 120 Ohm impedance must be connected.</p> <p>To obtain a high-frequency impedance of 120 Ohm without loading the cable with direct current, the Modbus line terminator is optimized in the form of an RC cell: 120 Ohm in series with a 1 nF capacitor and two 10 cm wires for direct connection to the 5-pin connector of the last Modbus interface module, between D0 and D1.</p>
Ground polarity	The ground circuit (0 V of an optional power supply) must be connected directly to a protected earth, preferably at a single point on the bus. This point is usually placed on the master or its slaves.
Trunk cable	A pair of shielded twisted cables and a third conductor at minimum.
Maximum length of bus	1000 m at 19,200 Baud with the Schneider Electric 50965 cable

Setting the Modbus Address Parameters

The Acti 9 Smartlink device addressing is performed using two thumbwheels:

- The left-hand thumbwheel sets the tens.
- The right-hand thumbwheel sets the units.

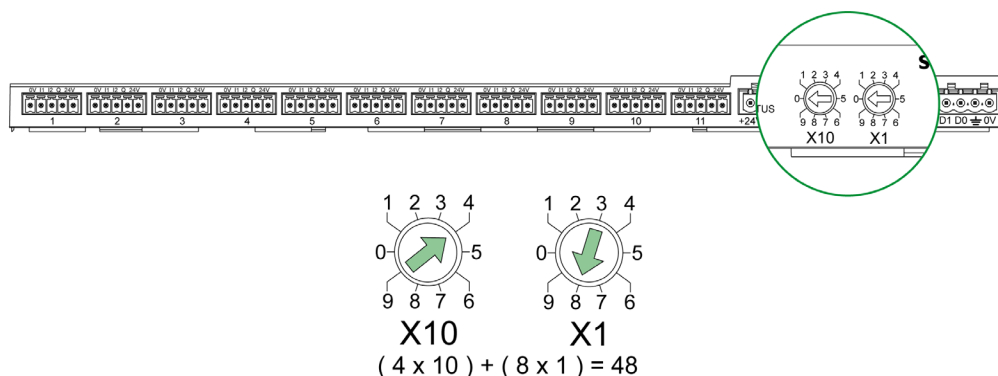

NOTE:

- The Acti 9 Smartlink device addressing must be between 01 and 99.
- A standard Modbus network consists of up to 31 slaves.
- In run mode, the user can change the Modbus slave address without having to de-energize the Acti 9 Smartlink.
- To reset the Acti 9 Smartlink factory settings (pulse weight at value 10, meters at 0, communication parameters), proceed as follows:
 - De-energize Acti 9 Smartlink
 - Set the Modbus address to value 00
 - Re-energize Acti 9 Smartlink
 - Set the selected address

Chapter 6

Connection of Input/Output Channels

What Is in This Chapter?

This chapter contains the following topics:

Topic	Page
Acti 9 Devices with Ti24 Interface	44
Meters	45
Volt-Free Low Level Indication Contact	46
Volt-Free Standard Indication Contact	47
Surge Arresters	48
Contactors and Relay (Not in the Acti 9 Range)	51
Direct Output Connection	52
Indirect Output Connection	53
Generating Summary Data Using iOF+SD24 or OF+SD24	54

Acti 9 Devices with Ti24 Interface

Overview

Devices (iACT24, iATL24, iOF+SD24, OF+SD24, RCA iC60, Reflex iC60) can be connected to the Acti 9 Smartlink with Acti 9 communication system pre-assembled cables.

Wiring

The following figure shows the connection of devices to the Acti 9 Smartlink using pre-assembled cables:

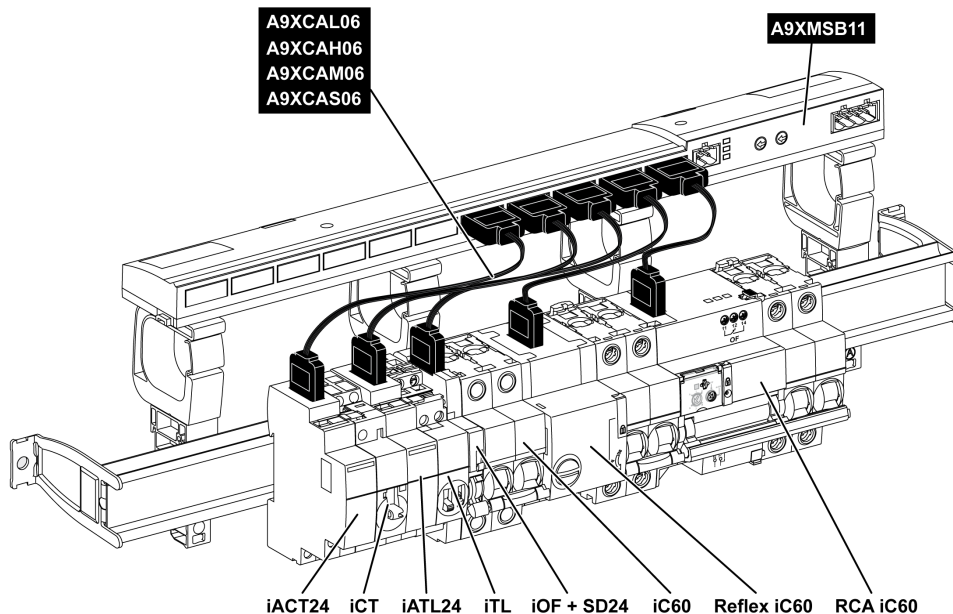

NOTE: A9XCAU06 or A9XCAC01 cable could be used to link Acti 9 devices with Ti24 interface to Acti 9 Smartlink.

In this case, for the connection of iACT24 and iATL24, input I2 must be connected on both ends of A9XCAU06 or A9XCAC01 cable.

Meters

Overview

The iEM2000T, iEM3110, iEM3155, iEM3210, iEM3255, and iEM3355 products are kilowatt-hour meters from the Schneider Electric range.

Meters not in the Acti 9 range can be controlled by an Acti 9 Smartlink channel. These meters must have the following characteristics:

- One pulse output
- Compatibility with standard CEI 62053-31

Wiring

iEM2000T, iEM3110, iEM3155, iEM3210, iEM3255, and iEM3355 kilowatt-hour meters can be connected to channel N ($1 \leq N \leq 11$) of an Acti 9 Smartlink module with an A9XCAU06 or A9XCAC01 pre-wired cable: molded connector (at Acti 9 Smartlink end), and with five wires (at iEM2000T end).

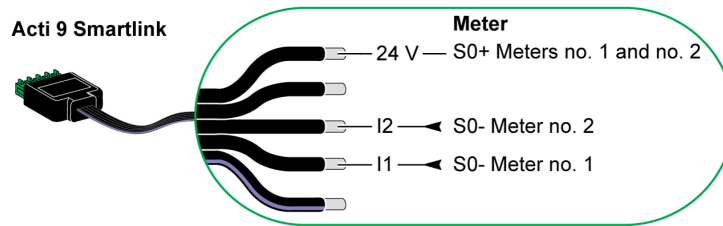

NOTE: A single Acti 9 Smartlink channel can take account of two meters, one meter on input I1 and 1 meter on input I2.

NOTE:

- Do not connect 2 wires in each of the Ti24 connector terminals (A9XC2412).
- Do not connect a wire with cable end in each of the Ti24 connector terminals.

Example of Connection of iEM2000T Meters

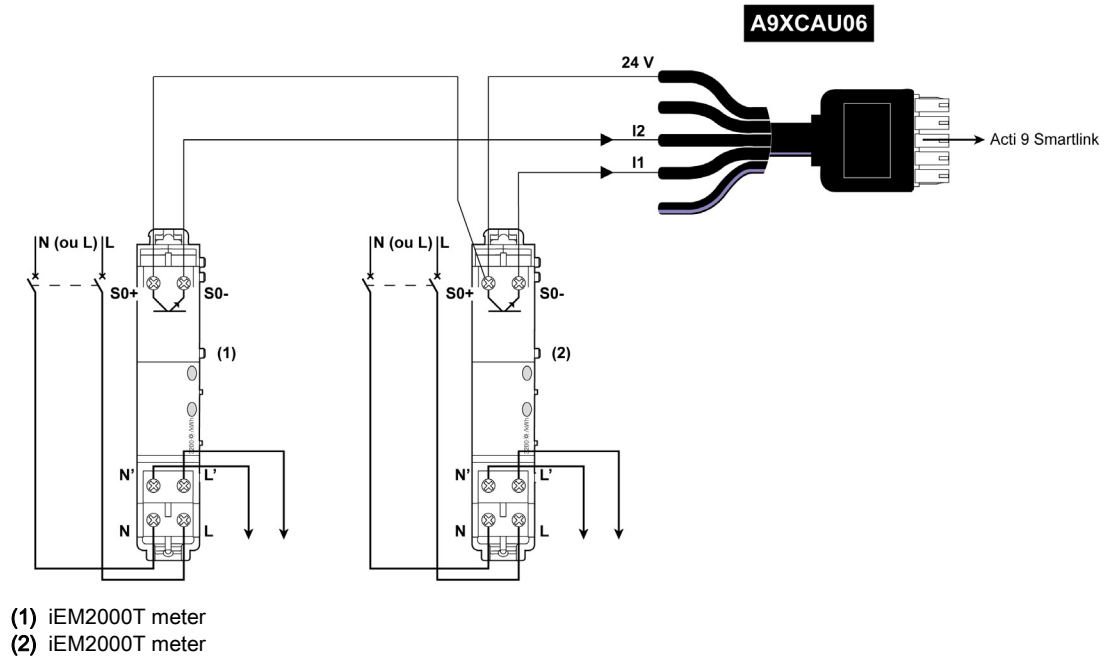

Volt-Free Low Level Indication Contact

Overview

A low level type indication contact (NO or NC) can be connected to input I1 or I2 of an Acti 9 Smartlink channel.

NOTE: A single Acti 9 Smartlink channel can take account of two indication contacts, one contact on input I1 and one contact on input I2.

Wiring

An indication contact can be connected with an A9XCAU06 or A9XCAC01 pre-wired cable: molded connector (at Acti 9 Smartlink end), and with the five wires (indication contact end).

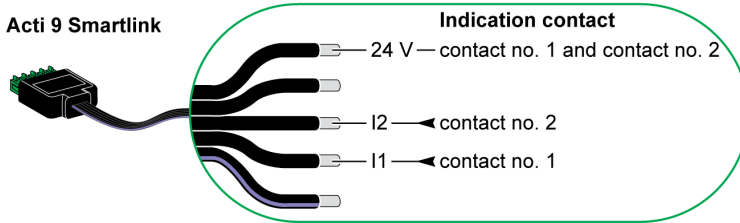

NOTE:

- Do not connect 2 wires in each of the Ti24 connector terminals (A9XC2412).
- Do not connect a wire with cable end in each of the Ti24 connector terminals.

Example of Connection

The OF and SD contacts of a NSX circuit breaker could be directly connected to Acti 9 Smartlink.

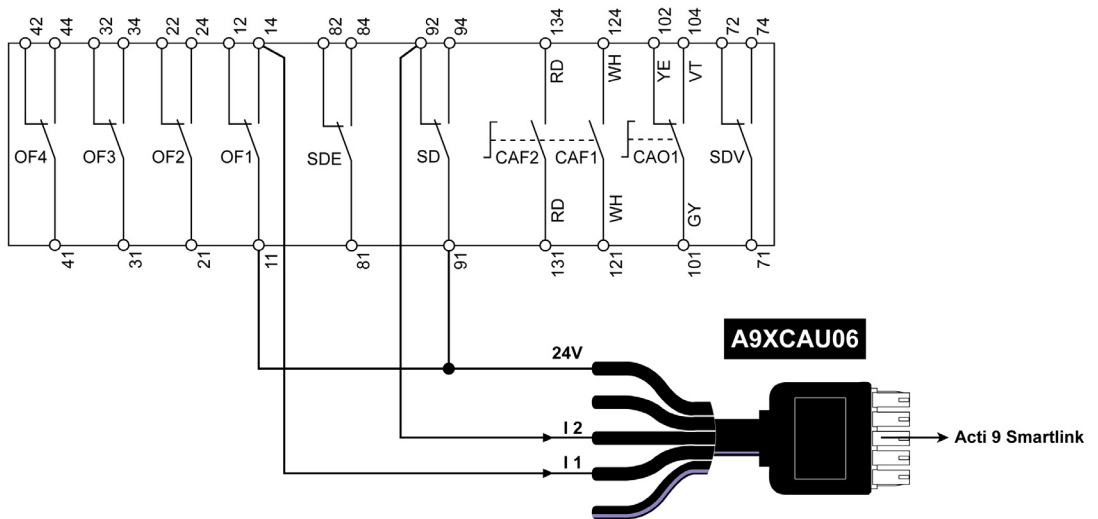

Volt-Free Standard Indication Contact

Overview

A standard indication contact (NO or NC) can be connected to input I1 or I2 of an Acti 9 Smartlink channel.

NOTE: A single Acti 9 Smartlink channel can take account of two indication contacts, one contact on input I1 and one contact on input I2. The electrical diagram must be indirect between Acti 9 Smartlink and this device: a low level relay must be installed between the contact of this device and Acti 9 Smartlink.

Wiring

An indication contact can be connected with an A9XCAU06 or A9XCAC01 pre-wired cable: molded connector (at Acti 9 Smartlink end), and with the five wires (indication contact end).

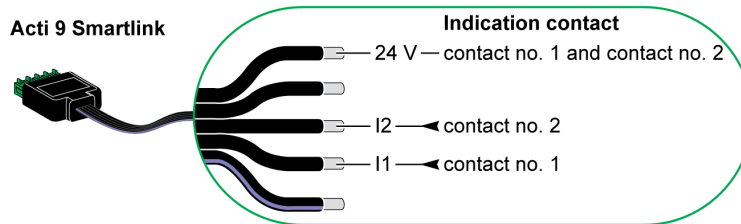

NOTE:

- Do not connect 2 wires in each of the Ti24 connector terminals (A9XC2412).
- Do not connect a wire with cable end in each of the Ti24 connector terminals.

Example of Connection

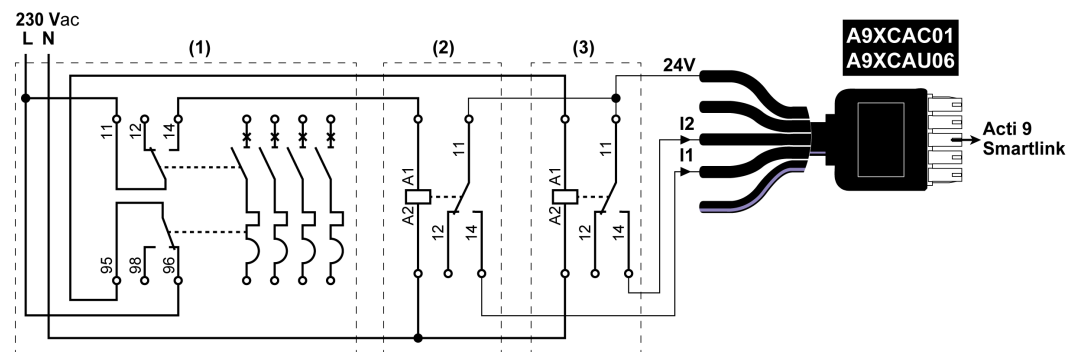

- (1) NG125 circuit breaker: OF+SD auxiliary contacts with a minimum current of 100 mA
- (2) iRBN relay for OF signal
- (3) iRBN relay for SD signal

Surge Arresters

Overview

Acti 9 surge arresters can be connected to Acti 9 Smartlink:

- The remote transfer contact (indication contact: NO) of an Acti 9 surge arrester can be connected to input I1 or I2 of an Acti 9 Smartlink channel.
- The SD fault-trip indication contact (indication contact: NC) of the circuit breaker associated to an Acti 9 surge arrester can be connected to input I1 or I2 of an Acti 9 Smartlink channel.

NOTE: A single Acti 9 Smartlink channel can take account of two indication contacts, one contact on input I1 and one contact on input I2.

Wiring

An indication contact can be connected with an A9XCAU06 or A9XCAC01 pre-wired cable: molded connector (at Acti 9 Smartlink end), and with the five wires (indication contact end).

The following wiring is dedicated to surge arresters:

- iPRD
- iPRD 40r PV
- iQuick PRD

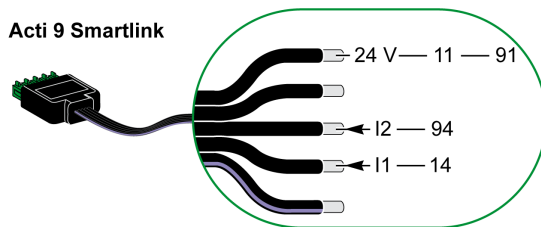

The following wiring is dedicated to surge arresters:

- iPRF1 12.5r
- PRD1 25r
- PRD1 Master

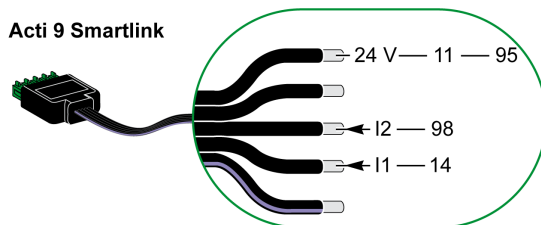

NOTE:

- Do not connect 2 wires in each of the Ti24 connector terminals (A9XC2412).
- Do not connect a wire with cable end in each of the Ti24 connector terminals.

Examples of Connection

The following electrical diagram is dedicated to iPRD surge arrester.

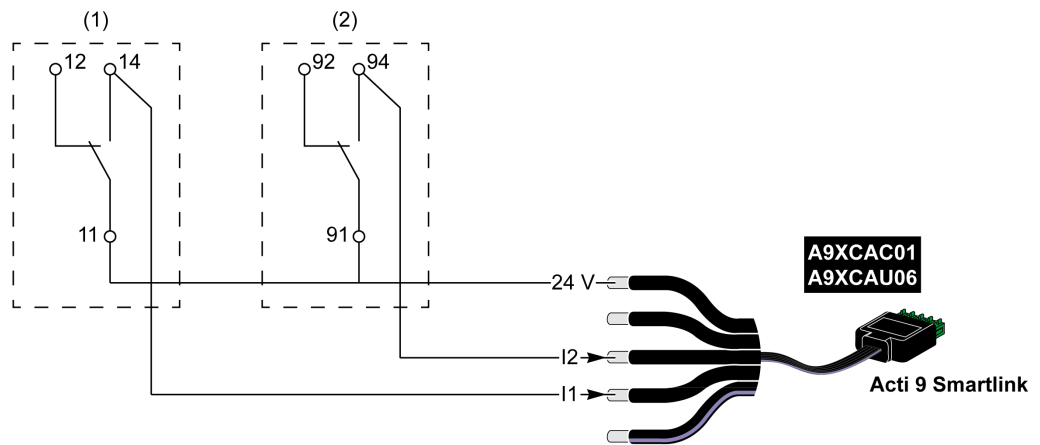

- (1) Remote transfer contact of iPRD surge arrester: cartridges status
- (2) iSD fault-trip indication contact of iC60 circuit breaker associated to iPRD surge arrester

The following electrical diagram is dedicated to surge arresters:

- iPRD 40r PV
- iQuick PRD

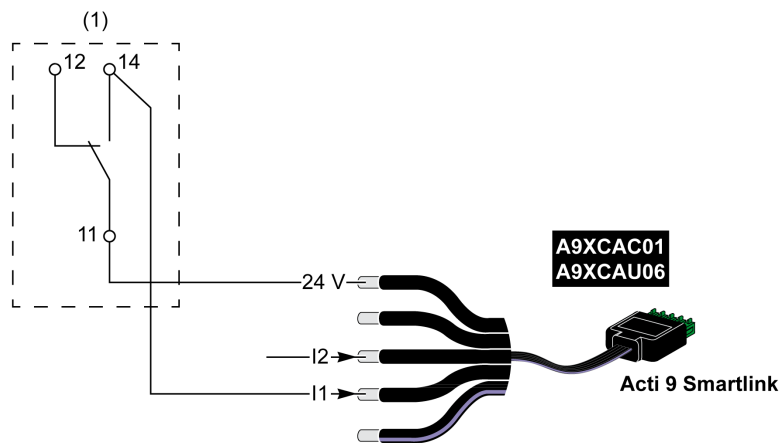

- (1) Remote transfer contact of surge arrester: cartridges status

The following electrical diagram is dedicated to iPRF1 12.5r surge arresters:

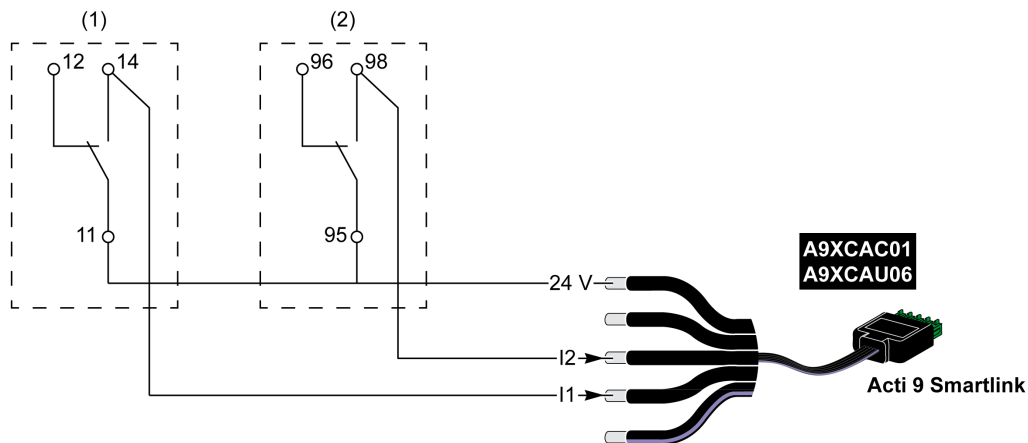

- (1) Remote transfer contact of iPRF1 12.5r surge arrester: surge arrester status
- (2) iSD fault-trip indication contact of NSX160F or NG125 circuit breaker associated to iPRF1 12.5r surge arrester

The following electrical diagram is dedicated to surge arresters:

- PRD1 25r
- PRD1 Master

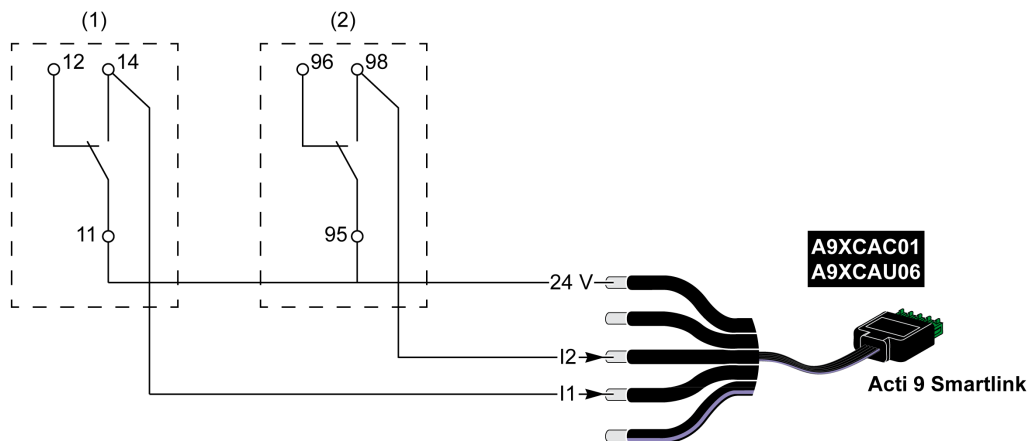

- (1) Remote transfer contact of PRD1 25r or PRD1 Master surge arrester: cartridges status
- (2) iSD fault-trip indication contact of NSX160 circuit breaker associated to PRD1 25r or PRD1 Master surge arrester

Contactor and Relay (Not in the Acti 9 Range)

Overview

A contactor or relay powered with 24 Vdc can be connected to Acti 9 Smartlink. This should have the following characteristics:

- The contactor or relay coil must not draw more than 100 mA
- The indication contact must be low level type

Only contactors in the Acti 9 range can be connected to Acti 9 Smartlink using the iACT24 auxiliary.

Wiring

A contactor can be connected with an A9XCAU06 or A9XCAC01 pre-wired cable: molded connector (at Acti 9 Smartlink end), and with five wires (at contactor end).

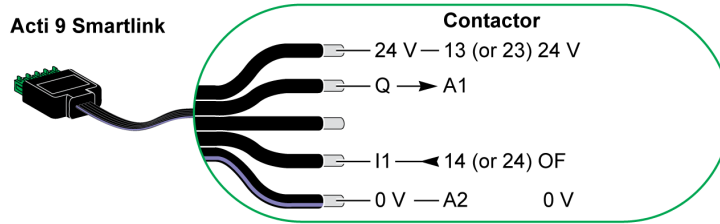

NOTE:

- Do not connect 2 wires in each of the Ti24 connector terminals (A9XC2412).
- Do not connect a wire with cable end in each of the Ti24 connector terminals.

Example of Connection

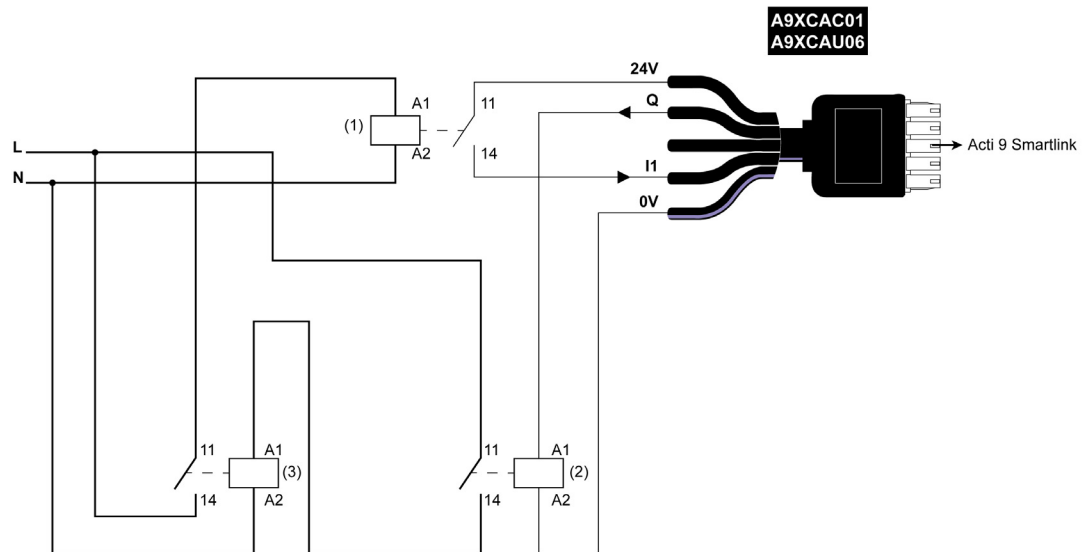

- (1) Low level relay (for example, iRBN)
- (2) 24 Vdc relay
- (3) Power contactor (e.g. TeSys D, type LC1)

Direct Output Connection

Overview

An indication device or a PLC input can be directly connected to the output (Q) of Acti 9 Smartlink channel.

The connected device should have the following characteristics:

- To be powered with 24 Vdc
- The consumption must be less than 100 mA

Wiring

The wiring can be done with an A9XCAU06 or A9XCAC01 pre-wired cable: molded connector (at Acti 9 Smartlink end), and with five wires (at contactor end).

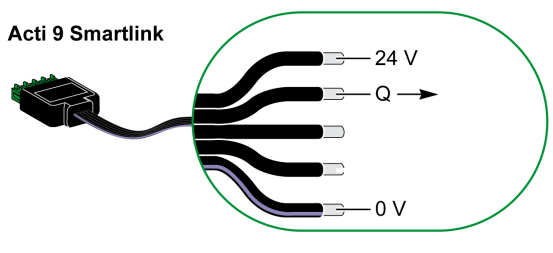

NOTE:

- Do not connect 2 wires in each of the Ti24 connector terminals (A9XC2412).
- Do not connect a wire with cable end in each of the Ti24 connector terminals.

Example of Connection

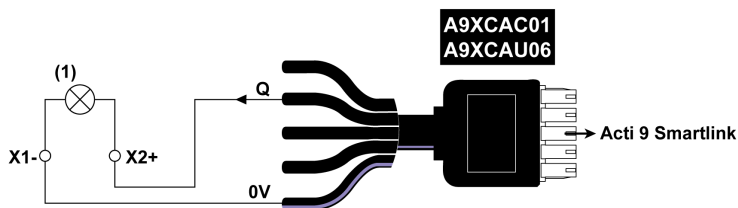

(1) Indication light 24 Vdc

Indirect Output Connection

Overview

Any device (for example: motor) that needs a command circuit of more than 100 mA can be controlled by the output (Q) of a channel of Acti 9 Smartlink. The electrical diagram must be indirect between Acti 9 Smartlink and this device: a low level relay must be installed between the command of this device and Acti 9 Smartlink.

Wiring

The wiring can be done with an A9XCAU06 or A9XCAC01 pre-wired cable: molded connector (at Acti 9 Smartlink end), and with five wires (at contactor end).

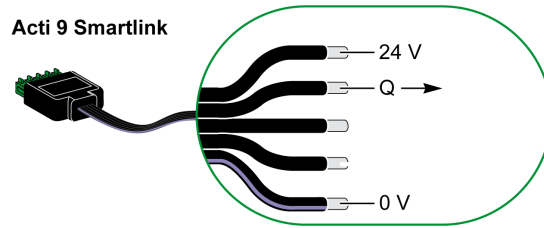

NOTE:

- Do not connect 2 wires in each of the Ti24 connector terminals (A9XC2412).
- Do not connect a wire with cable end in each of the Ti24 connector terminals.

Example of Connection

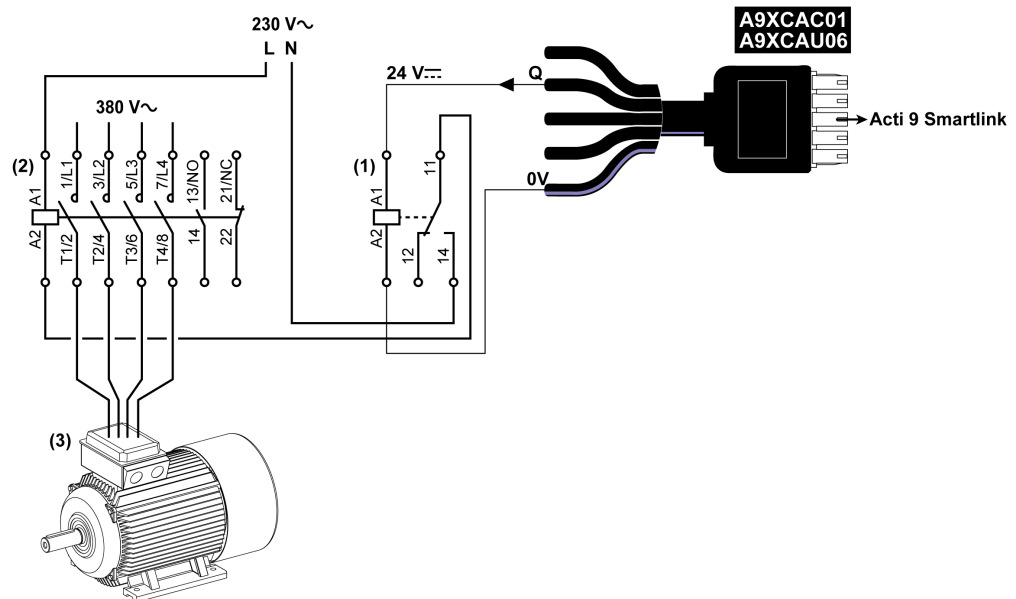

- (1) Relay iRTBT
- (2) Contactor Tesys D LC1D•25 with an 230 Vac coil
- (3) Motor 10 kW with power supply 3-phases 380 Vac

Generating Summary Data Using iOF+SD24 or OF+SD24

Overview

The electrical summary of the SD contacts or summary of the OF contacts can be generated with iOF+SD24 and/or OF+SD24 auxiliaries.

The electrical summary of the OF signals can be done by cabling in series of all OF signals and by connecting this circuit to the I1 input of a channel of Acti 9 Smartlink.

The electrical summary of the SD signals can be done by cabling in series of all SD signals and by connecting this circuit to the I2 input of another channel of Acti 9 Smartlink.

The OF connections (on I1 input) and the SD connections (on I2 input) cannot be connected to the same channel of Acti 9 Smartlink, as the summary information dedicated to the OF signals cannot be separated from the summary information dedicated to the SD signals in Acti 9 Smartlink.

The summary of OF (or SD) signals can be wired in series using the A9XC2412 15-pin connector (spring cage). A maximum of 10 OF (or SD) signals can be wired in the same summary.

Wiring SD Contacts on iOF+SD24 or OF+SD24 in Series

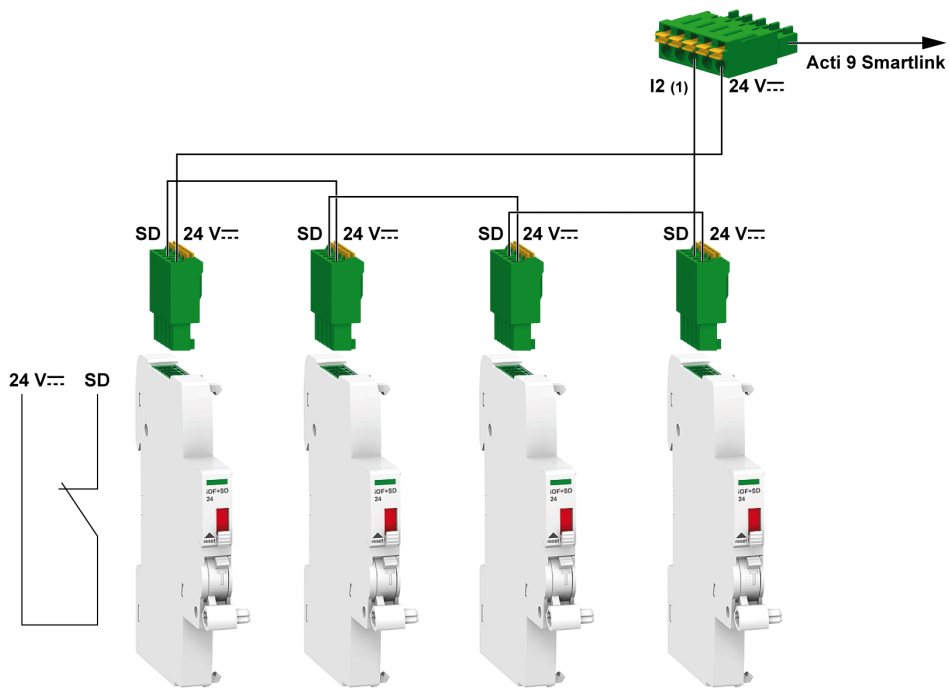

(1) Input I2 (of a channel) on Acti 9 Smartlink or PLC input

Wiring OF Contacts on iOF+SD24 or OF+SD24 in Series

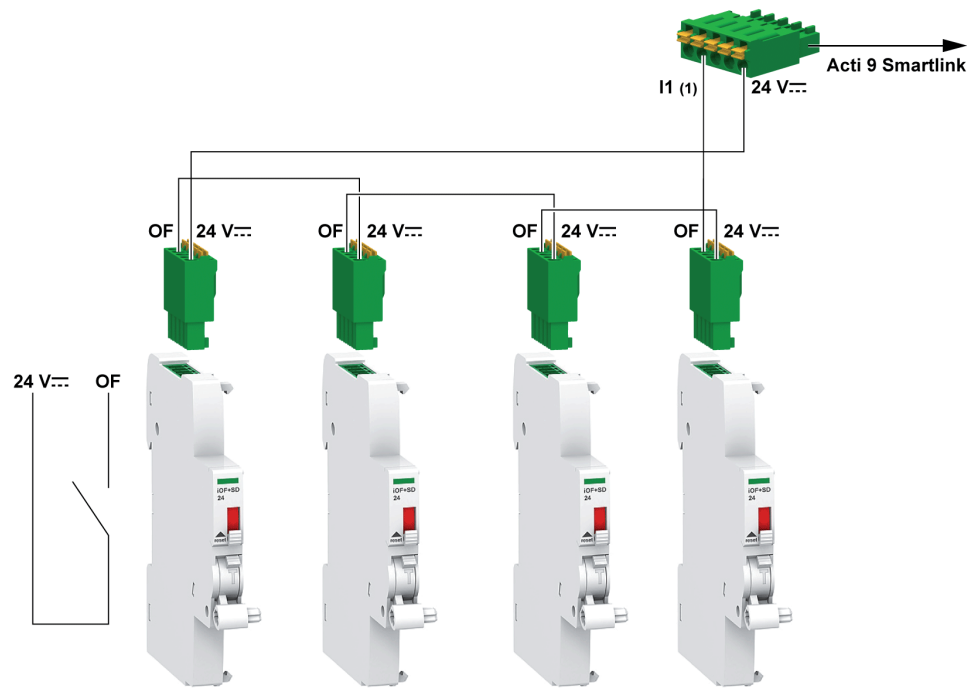

(1) Input I1 (of a channel) on Acti 9 Smartlink or PLC input

Chapter 7

Test

Acti 9 Smart Test Software

Overview

The main purpose of the Acti 9 Smart Test software is to help technical personnel to check that all devices are correctly wired and function properly after installation.

The Acti 9 Smart Test software offers a quick test process based on a very intuitive Graphical User Interface.

This software has the ability to deal with multiple Acti 9 Smartlink devices at the same time. They can be chained and multiple Acti 9 devices can be connected to the computer using Smartlink Modbus, EGX/IFE, and Smartlink Ethernet network. The maximum number of Acti 9 Smartlink devices that can be connected for Smartlink Modbus and EGX/IFE network is 10. The maximum number of Acti 9 Smartlink slave devices that can be connected for Smartlink Ethernet network is eight. The slave devices can include Acti 9 Smartlink Modbus.

The Acti 9 Smart Test software is used to update the Acti 9 Smartlink firmware.

The Acti 9 Smartlink Modbus can only be updated through IFE or Acti 9 Smartlink Ethernet. The firmware upgrade for Acti 9 Smartlink Modbus is not supported through EGX gateway.

When Acti 9 Smartlink Modbus firmware upgrade is initiated, Acti 9 Smartlink Modbus product should be in an isolated network along with the gateway. No other Modbus master should be polling any other Modbus device connected in the same network.

Main Functions

The Acti 9 Smart Test software has four main functions:

- Testing the installation
- Generating test reports
- Upgrading the firmware version of Acti 9 Smartlink
- Configuring the Acti 9 devices connected to Acti 9 Smartlink and recovering the configuration of Acti 9 Smartlink channels

In order to test the installation, the software:

- Tests the communication network (Modbus SL/Modbus TCP/IP).
- Tests the connection and the status of the electrical devices connected to Acti 9 Smartlink.

Also, the software provides the following reports:

- List of tested devices (*.pdf* and *.xlsx* files)
- Acti 9 Smartlink channels assignment (*.dxff* file)

The screenshot shows the main interface of the Acti 9 Smart Test software.

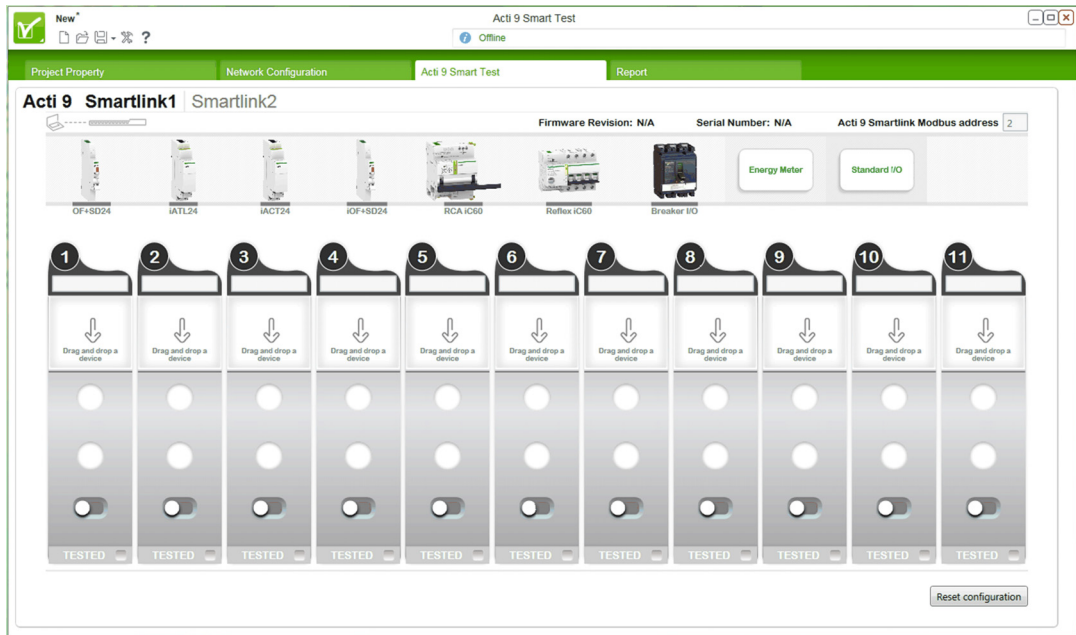

Downloading and Installation

Acti 9 Smart Test software can be downloaded from Schneider Electric website.

Acti 9 Smart Test software is available in two versions:

- Full version including Microsoft .NET Framework (package that contains light version and Microsoft .NET Framework)
- Light version without Microsoft .NET Framework

We recommend to install the full version of Microsoft .NET Framework (3.5 or later) if not installed on the PC.

The table describes the procedure for installing the Acti 9 Smart Test software:

Step	Description
1	Go to the Schneider Electric website: www.schneider-electric.com or Schneider Electric country website.
2	In the search field, enter SmartTest without space character.
3	Select "Acti 9 Smart Test Software 3.4.7 (with .NET Framework)" or "Acti 9 Smart Test Software 3.4.7 (without .NET Framework)".
4	Download the Acti 9 Smart Test software.
5	Install the Acti 9 Smart Test software.
6	Acti 9 Smart Test user guide can be downloaded from Schneider Electric web site. <ul style="list-style-type: none"> ● In the search field, enter: <ul style="list-style-type: none"> ○ DOCA0029EN for English user guide, ○ DOCA0029ES for Spanish user guide, ○ DOCA0029FR for French user guide, ○ DOCA0029DE for German user guide, ○ DOCA0029IT for Italian user guide, ○ DOCA0029PT for Portuguese user guide, ○ DOCA0029RU for Russian user guide, ○ DOCA0029ZH for Chinese user guide, ● Select the user manual. ● Download the user guide.

Acti 9 Smart Test software is also available in the Power Launcher library.

Chapter 8

Setting Up Modbus Communication

What Is in This Chapter?

This chapter contains the following topics:

Topic	Page
Modbus Master/Slave Principle	60
Setup	63
Resetting with Factory Parameters	64
Acti 9 Smartlink Device Functions	65
Modbus Functions	67
Modbus Exception Codes	68
Description of LEDs	69

Modbus Master/Slave Principle

Overview

The Modbus protocol exchanges data using a request/response mechanism between a master and a slave. The master/slave principle is a type of communication protocol in which a device (the master) controls one or more devices (the slaves). A standard Modbus network consists of one master and up to 31 slaves.

NOTE: For more information, a detailed description of the Modbus protocol is available on www.modbus.org.

Characteristics of the Master/Slave Principle

The master/slave principle has the following characteristics:

- Only one master at a time is connected to the network.
- Only the master can launch communication and send requests to slaves.
- The master can address each slave individually using its dedicated address or all slaves simultaneously using address 0.
- The slaves can only send responses to the master.
- Slaves cannot launch communication with either the master, or the other slaves.

Master/Slave Communication Modes

The Modbus protocol can exchange data using two communication modes:

- Request/response mode
- Broadcast mode

Each Acti 9 Smartlink has a Modbus address (1 to 99), and concentrates data from connected devices on its 11 channels (Ti24 interface).

The states and orders for each device connected to Acti 9 Smartlink are accessible in registers whose address depends on the channel (1 to 11) on which the device is connected.

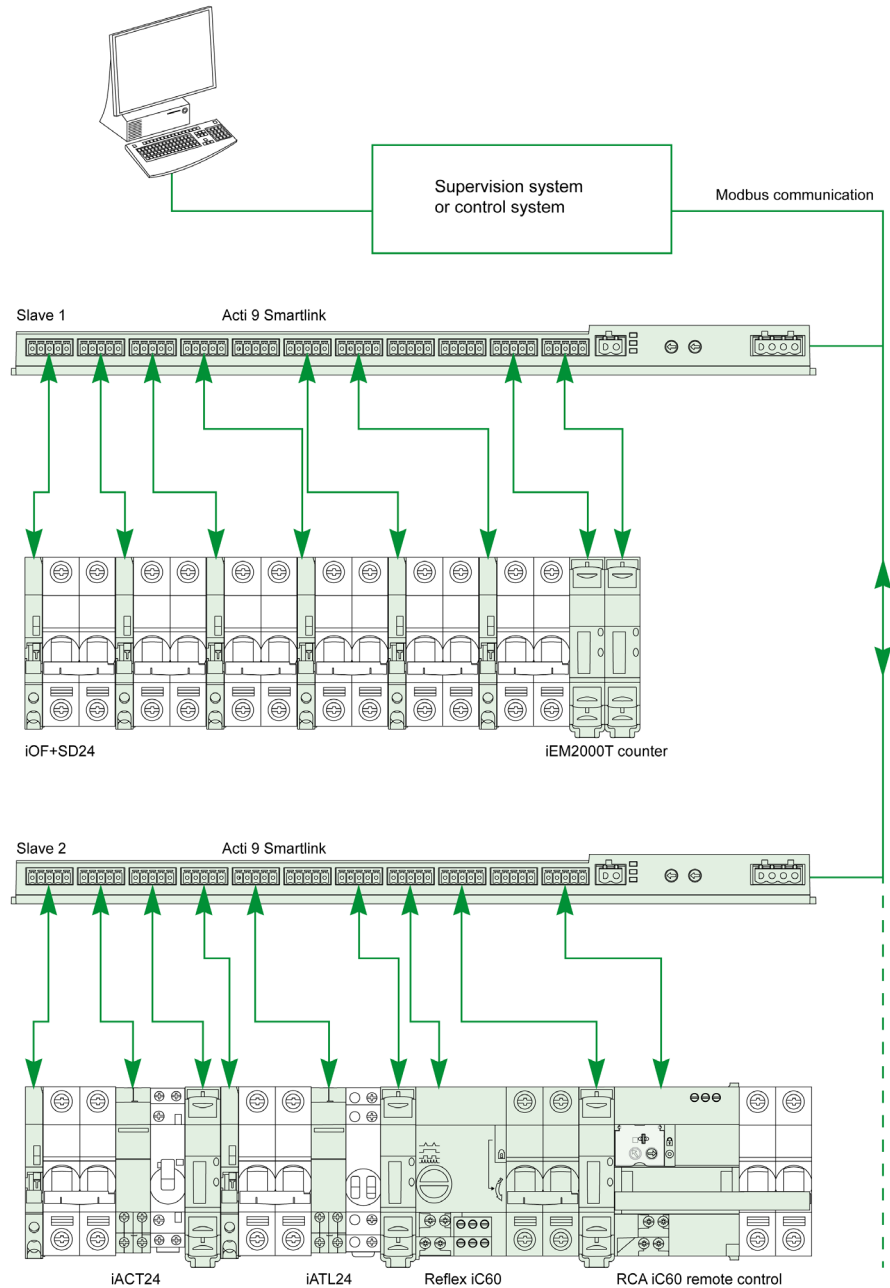

Request/Response Mode

In request/response mode, the master addresses 1 slave using the slave's dedicated address. The slave processes the request, then responds to the master.

Broadcast Mode

In broadcast mode, the master addresses all the slaves using address 0. Slaves do not respond to broadcast messages.

Turnaround Time

The turnaround time T_r is the time between the end of receipt of a request and sending the response.

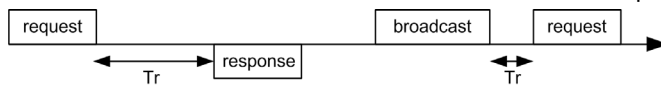

The typical value of the turnaround time T_r is less than 10 ms with the Modbus protocol.

Data Exchange

The Modbus protocol uses two data types:

- Bits
- 16-bit words called registers

Each register has a register number. Each data type (bit or register) has a 16-bit address.

Messages exchanged with the Modbus protocol contain the address of the data to be processed.

Frames

All frames exchanged with the Modbus protocol are 256 bytes maximum and consist of four fields:

Field	Definition	Size	Description
1	Slave number	1 byte	Destination of the request ● 0: broadcast (all slaves are affected) ● 1...247: unique destination
2	Function code	1 byte	Modbus (<i>see page 67</i>) Function
3	<ul style="list-style-type: none"> ● Data ● Sub-function code 	n bytes	<ul style="list-style-type: none"> ● Request or response data ● Sub-function code
4	Check	2 bytes	CRC16 (to check transmission errors)

Data Format

The data format is configured as shown in the following table according to Modbus RTU format:

Start	Data	Parity	Stop
1 bit	8 bits	1 bit	1 bit

NOTE: The Modbus RTU data format is composed of 11 bits.

Even parity is required, other modes (odd parity, no parity) may be also used.

If no parity is implemented in the Modbus Master, an additional stop bit must be transmitted by the Modbus Master to fill out the character frame to a full 11 bit asynchronous character.

NOTE: For more information, a detailed description of the Modbus protocol is available on www.modbus.org.

Setup

Initialization

The table describes the two initialization phases for the Acti 9 Smartlink device:

Phase	Description
1	<ul style="list-style-type: none"> Acti 9 Smartlink must be connected to a Modbus master. When the 24 Vdc power supply is activated, the Modbus communication for the Acti 9 Smartlink device is initialized and addressing is taken into account.
2	After receiving a maximum of 25 frames from the master, Acti 9 Smartlink automatically adapts its communication parameters to those of the master (speed, parity and number of stop bits).

NOTE: The Modbus network communication speed is the same for all serial connections for the Modbus devices used. It is imposed by the lowest communication speed of a slave device.

NOTE: Automatic adaptation to the communication parameters only occurs on powering up the Acti 9 Smartlink.

Setting the Modbus Address Parameters

The Acti 9 Smartlink device addressing is performed using two thumbwheels:

- The left-hand thumbwheel sets the tens
- The right-hand thumbwheel sets the units

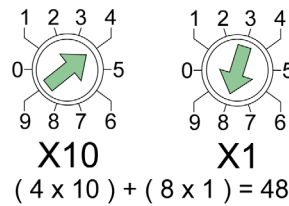
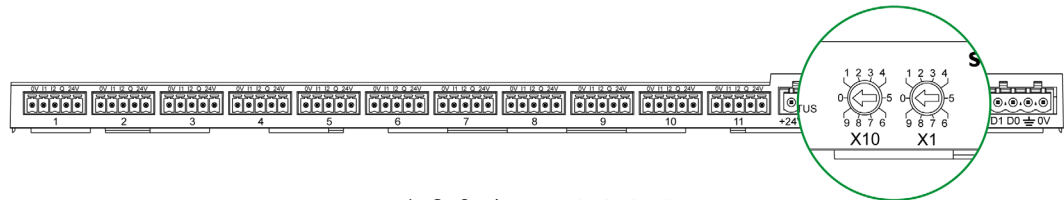

NOTE:

- The Acti 9 Smartlink device address must be between 01 and 99.
- A standard Modbus network consists of up to 31 slaves.
- In run mode, the user can change the Modbus slave address without having to de-energize the Acti 9 Smartlink.

Communication Parameters

The communication parameter values are as follows:

Settings	Authorized Values	Default Value
Data rate (in Baud)	4800, 9600, and 19,200	19,200
Parity	<ul style="list-style-type: none"> Even and one stop bit Odd and one stop bit No parity (parity bit eliminated), 2 stop bits are needed. 	Even (with one stop bit)

NOTE: The Modbus network communication speed is the same for all serial connections for the Modbus devices used. It is imposed by the lowest communication speed of a slave device.

Resetting with Factory Parameters

Description

To reset the Acti 9 Smartlink device, proceed as follows:

Step	Action
1	De-energize Acti 9 Smartlink.
2	Set the Modbus address to value 00.
3	Re-energize Acti 9 Smartlink.

The reset data is as follows:

- The communication parameters become: 19,200 Baud, even parity, one stop bit.
- The operation counters are set to 0.
- The running hours counters are set to 0.
- The counter modification dates are set to the value "1 January 2000".
- The counter pulse weights are set to 10.

Acti 9 Smartlink Device Functions

Acti 9 Device Command and Control Functions

The products concerned are:

- iOF+SD24
- OF+SD24
- iACT24
- iATL24
- Reflex iC60
- RCA iC60

Input state acquisition function:

- Open/closed state (input I1 of the Ti24 interface)
- Trip signal (input I2 of the Ti24 interface) for the protection devices

Open and close order function:

Each Acti 9 Smartlink channel offers an output (Q):

- Output Q is set to 1 by forcing the bit of the channel concerned to 1 in the activation register (ON). The Modbus command register bit is automatically set to 0 by Acti 9 Smartlink as soon as the order has been sent to output Q.
- Output Q is set to 0 by forcing the bit of the channel concerned to 1 in the deactivation register (OFF). The Modbus command register bit is automatically set to 0 by Acti 9 Smartlink as soon as the order has been sent to output Q.

Installation life management function:

- Acti 9 Smartlink stores the number of changes of state (or number of operations) for the control and protection devices, which allows the wear on these devices to be estimated. To do this, Acti 9 Smartlink counts the changes of state of input I1 (on falling edge) for each channel.
- Acti 9 Smartlink stores the number of protection device trips, thus highlighting faults in the electrical installation. To do this, Acti 9 Smartlink counts the changes of state of input I2 (on falling edge) for each channel.
- Acti 9 Smartlink stores the total time when control products are closed, which allows the wear on controlled loads to be estimated. To do this, Acti 9 Smartlink counts the changes of state of input I1 (OF state) for each channel.
- This data (number of changes of state, running hours) can be reset to 0, and the initialization date can be stored.

Command and Control Functions of Devices Not in the Acti 9 Range

Input state acquisition function:

All other types of device offering low level I/O (24 Vdc) can be connected to the 22 inputs and 11 outputs offered by Acti 9 Smartlink. Each Acti 9 Smartlink channel offers 2 inputs (I1 and I2).

Command function:

Each Acti 9 Smartlink channel offers an output (Q).

- Output Q is set to 1 by forcing the bit of the channel concerned to 1 in the activation register (ON). The Modbus command register bit is automatically set to 0 by Acti 9 Smartlink as soon as the order has been sent to output Q.
- Output Q is set to 0 by forcing the bit of the channel concerned to 1 in the deactivation register (OFF). The Modbus command register bit is automatically set to 0 by Acti 9 Smartlink as soon as the order has been sent to output Q.

Counting Functions

Schneider Electric energy meters with pulse output:

- iEM2000T (the pulse weight equals 10)
- iEM3110 (the pulse weight can be configured)
- iEM3155 (the pulse weight can be configured)
- iEM3210 (the pulse weight can be configured)
- iEM3255 (the pulse weight can be configured)

Acti 9 Smartlink calculates the energy consumption and the average power between two pulses.

Energy consumption = Number of pulses counted × pulse weight

Average power between two pulses = (3600 × Pulse weight)/t; the result is expressed for one hour.

With t, the time in seconds between the last two pulses received.

Other types of meter with pulse output:

- water, gas meters, etc.
- Any type of meter whose pulse output complies with standard IEC 62053-21 (minimum pulse 30 ms).

The pulse weight can be configured.

Acti 9 Smartlink calculates the consumption and the average flow between two pulses.

Consumption = Number of pulses counted × pulse weight

Average flow = (3600 × pulse weight)/t; the result is expressed for one hour.

With t, the time in seconds between the last two pulses received.

The average power data (or average flow) between two pulses is reset to 0:

- After a duration $d = 3 \times t$; if $3 \times t$ is less than 5 seconds, the duration d equals five seconds
With t, the time in seconds between the last two pulses received.
- After 24 hours without a pulse
- After loss of the 24 Vdc input/output voltage

Every 10 minutes, the meter values are saved in the EEPROM memory.

Each time it changes, the value of each pulse is saved instantly in the EEPROM memory.

The meter parameter setting dates are saved instantly in the EEPROM memory.

System Behavior in the Event of Loss of the 24 Vdc Power Supply

Up to a duration of 10 ms, Acti 9 Smartlink is unaffected by voltage dips. If the voltage is below 19.2 Vdc (24 Vdc - 20%) for more than 10 ms, Acti 9 Smartlink changes to downgraded mode:

- All the outputs are set to zero. However the Acti 9 control auxiliaries (iACT24, iATL24, Reflex iC60, RCA iC60) distinguish this loss of voltage event in actual order. They do not therefore change state.
- The time between two write operations in the EEPROM memory is 10 min. Data previously written to this memory is not modified on loss of voltage. Saved values therefore date back a maximum of 10 min.
- Calculated power (or flow) values are not saved. They are set to zero.

System Behavior at the Time the 24 Vdc Power Supply is Energized or Returns

NOTE: The Acti 9 Smartlink power supply must be between 19.2 Vdc (24 Vdc - 20%) and 28.8 Vdc (36 Vdc - 20%).

- The outputs remain at zero.
- The Acti 9 control auxiliaries (iACT24, iATL24, Reflex iC60, RCA iC60) do not change status since they operate according to rising or falling edge.
- Data stored in the EEPROM memory is written to the corresponding registers (pulse weights, event counters, impulse counters, running hours counters, counter reset dates). The values in the registers are therefore those of the last save to the EEPROM memory. These values may differ from the last values read in the registers before the power failure.

NOTE: If the Acti 9 Smartlink thumbwheels are set to zero during the loss of voltage, Acti 9 Smartlink is reset when the power returns. For more information, see Resetting with factory parameters ([see page 64](#)).

Modbus Functions

General Description

The Modbus protocol offers functions for reading or writing data on the Modbus network. This protocol also offers diagnostic and network management functions.

Only Modbus functions managed by the Acti 9 Smartlink device are described here.

Table of Modbus Functions

The following table describes in detail the functions supported by Acti 9 Smartlink devices:

Function Code	Sub-Function Code	Function Name
01	–	Read n output or internal bits
02	–	Read n input bits
03	–	Read n output or internal words
05	–	Write 1 bit
06	–	Write 1 word
08	(1)	Modbus diagnostics
15	–	Write n bits
16	–	Write n words
43	14 ⁽²⁾	Read identification
	15 ⁽³⁾	Read the date and time
	16 ⁽⁴⁾	Write the date and time
100	4 ⁽⁵⁾	Read n non-adjacent words where $n \leq 100$.
		<p>NOTE: Thanks to the read distributed holding register function, the user can:</p> <ul style="list-style-type: none"> ● Avoid reading a large block of adjacent words when only a few words are needed. ● Avoid multiple use of function 3 in order to read non-adjacent words.
<p>(1) For more details, see the appendix describing function 8 (<i>see page 118</i>) (2) For more details, see the appendix describing function 43–14 (<i>see page 119</i>) (3) For more details, see the appendix describing function 43-15 (<i>see page 121</i>) (4) For more details, see the appendix describing function 43-16 (<i>see page 122</i>) (5) For more details, see the appendix describing function 100-4 (<i>see page 123</i>)</p>		

NOTE: For more information, a detailed description of the Modbus protocol is available on www.modbus.org.

Modbus Exception Codes

Exception Responses

Exception responses issued by the master or a slave can be the result of data processing errors. One of the following events can occur after a request from the master:

- If the slave receives the request from the master without a communication error and manages the request correctly, it sends back a normal response.
- If the slave does not receive the request from the master due to a communication error, it does not send back a response. The master program ends by applying a time delay condition to the request.
- If the slave receives the request from the master but detects a communication error, it does not send back a response. The master program ends by applying a time delay condition to the request.
- If the slave receives the request from the master without a communication error but cannot manage it (for example, the request consists of reading a register that does not exist), the slave sends back an exception response to inform the master of the nature of the error.

Exception Frame

The slave sends an exception frame to the master to indicate an exception response. An exception response consists of four fields:

Field	Definition	Size
1	Slave number	1 byte
2	Exception function code	1 byte
3	Exception code	n bytes
4	Check	2 byte

Managing Modbus Exceptions

The exception response frame consists of 2 fields that distinguish it from a normal response frame:

- The exception response's exception function code is the same as the original request function code plus 128 (0x80).
- The exception code depends on the communication error detected by the slave.

The table describes the exception codes managed by the Acti 9 Smartlink device:

Exception Code	Name	Description
01	Illegal function	The function code received in the request is not a permitted action for the slave. It is possible that the slave is in an unsuitable state to process a specific request.
02	Illegal data address	The data address received by the slave is not a permitted address for the slave.
03	Illegal data value	The value of the request data field is not a permitted value for the slave.
04	Slave device failure	The slave is unable to perform a required action due to an unrecoverable error.
06	Slave device busy	The slave is busy processing another command. The master should send the request once the slave is free.

NOTE: For more information, a detailed description of the Modbus protocol is available on www.modbus.org.

Access to Variables

A Modbus variable can have the following attributes:

- Read-only
- Read/write
- Write-only

NOTE: An attempt to write to a read-only variable generates an exception response.

Description of LEDs

LED Status

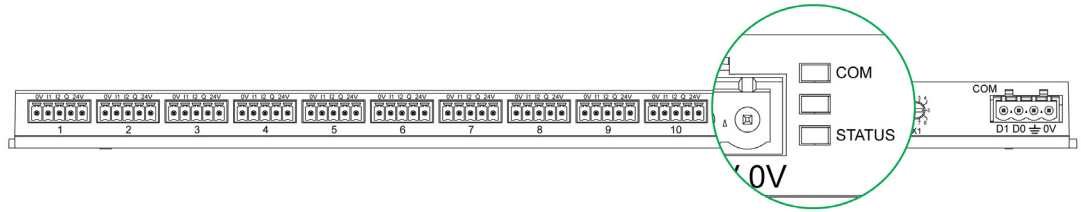

The table lists the LED status according to the operating mode:

Mode	LEDs	Status
Initialization	<p>COM: Yellow LED</p> <p>STATUS: Green LED</p>	<p>COM: On, yellow</p> <p>STATUS: On, green</p>
Start-up	<p>COM: Yellow LED</p> <p>STATUS: Alternating Green and Red LED</p>	<p>COM :</p> <ul style="list-style-type: none"> On yellow during communication with the Modbus serial port Off if there is no Modbus communication <p>STATUS: On alternately green and red once a second.</p>
Operation	<p>COM: Yellow LED</p> <p>STATUS: Green LED</p>	<p>COM :</p> <ul style="list-style-type: none"> On yellow during communication with the Modbus serial port Off if there is no Modbus communication <p>STATUS: Green LED permanently on</p>
Downgraded	<p>COM: Yellow LED</p> <p>STATUS: Orange LED</p>	<p>COM :</p> <ul style="list-style-type: none"> On yellow during communication with the Modbus serial port Off if there is no Modbus communication <p>STATUS: Permanently orange. Peripheral device problem:</p> <ul style="list-style-type: none"> Short-circuit or overload on the 24 Vdc I/O The power supply level is less than 19.2 Vdc
Failure	<p>COM: Yellow LED</p> <p>STATUS: Red LED</p>	<p>COM :</p> <ul style="list-style-type: none"> On yellow during communication with the Modbus serial port Off if there is no Modbus communication <p>STATUS: On, red (internal problem)</p>

Chapter 9

Tables of Modbus Registers

What Is in This Chapter?

This chapter contains the following sections:

Section	Topic	Page
9.1	General Description of Modbus Tables	72
9.2	Summary and Detailed Modbus Tables	78
9.3	Modbus Tables for Connected Products	91

Section 9.1

General Description of Modbus Tables

What Is in This Section?

This section contains the following topics:

Topic	Page
Overview	73
Modbus Table Format and Data Types	74
Global Modbus Address Table	77

Overview

Overview

All the Modbus tables in the Acti 9 Smartlink device have been designed to minimize the number of Modbus requests that the master system needs to send in order to collect the data prepared by Acti 9 Smartlink.

The Modbus tables in the Acti 9 Smartlink device are compact and are summaries of all the data collected on the 11 channels of the Acti 9 Smartlink device.

The Modbus tables in the Acti 9 Smartlink device are described in:

- The section presenting:
 - The overall list of Acti 9 Smartlink (*see page 77*) device address zones
 - The summary of channel 1 to 11 address zones (*see page 84*)
- The section presenting the address zones for each type of device that can be connected to Acti 9 Smartlink: iOF+SD24, OF+SD24, iACT24, iATL24, RCA iC60, Reflex iC60, iEM2000T, meter, contactor and impulse relay (*see page 91*)
- The section presenting the address zones for each type of data (status, orders, measurements and parameter settings) with a description of the summary zones and a description of the detailed data zones for each channel.

General Organization of Modbus Tables in Acti 9 Smartlink Devices

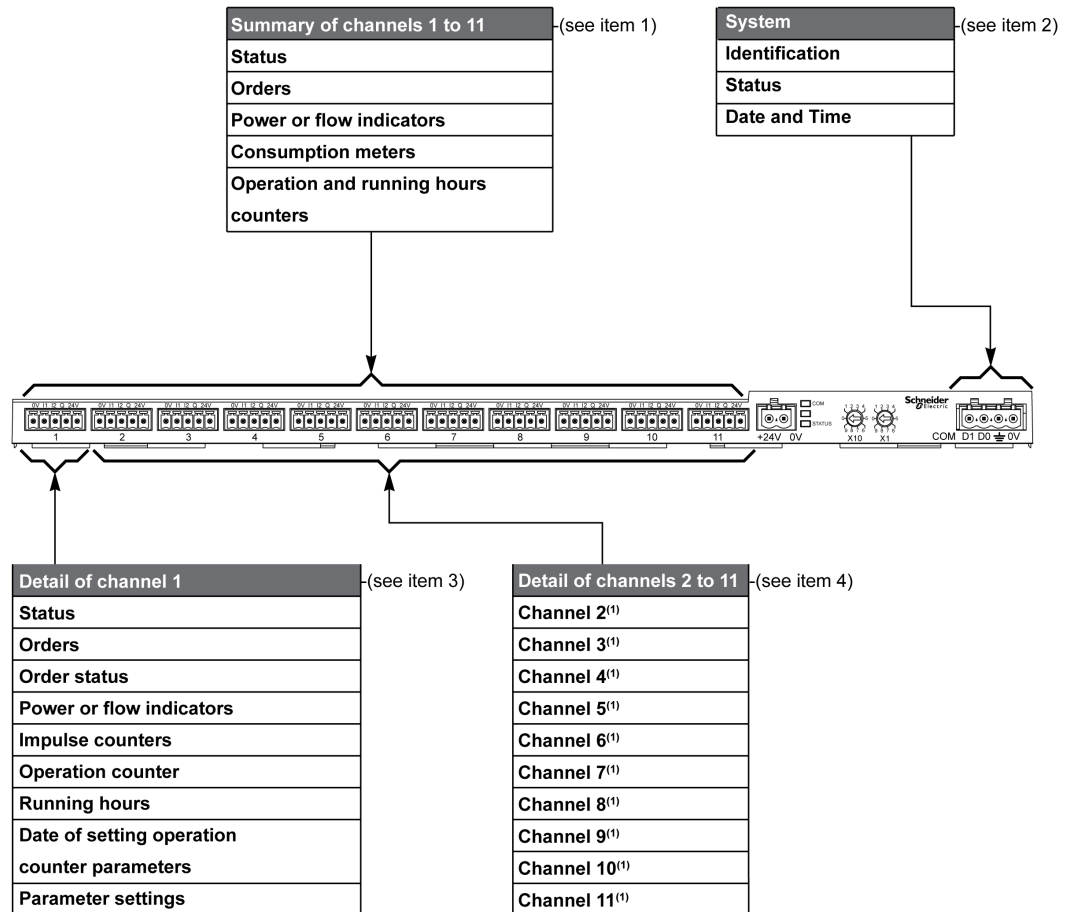

Item	Description	Link
1	Channel summary data	(see page 81)
2	System data independent of the channel	(see page 79)
3	Data for channel 1 Devices that can be connected to channel 1	(see page 84) (see page 91)
4	Data for channel 2 to 11 Devices that can be connected to channel 2 to 11	(see page 84) (see page 91)

Modbus Table Format and Data Types

Table Formats

Register tables have the following columns:

Address	No.	RW	X	Unit	Type	Range	Default Value	Svd	Function Code	Description
---------	-----	----	---	------	------	-------	---------------	-----	---------------	-------------

Designation	Description
Address	16-bit register address that allows the user to access the variable. The address is expressed in decimal notation. Modbus Address: The list of Modbus addresses, defined by the Modbus protocol, starts at 0. The detailed tables in subsequent chapters of this manual give the Modbus addresses. If the programmable controller (master) refers to the data model addresses, the addresses to be supplied to this controller must meet the following rule: Data model address = Modbus address + 1. If the programmable controller (Modbus master) refers to the protocol addresses, the addresses to be supplied to this controller must be the Modbus addresses.
No.	Number of 16-bit registers that need to be read/written to access the complete information.
RW	Whether the register is read only (R) or read-write (RW).
X	Scale factor: <ul style="list-style-type: none"> Scale "X1" means that the value of the register is the right one with the unit indicated. A scale of 10 means that the register contains the value multiplied by 10. The actual value is therefore the value of the register divided by 10. A scale of 0.1 means that the register contains the value multiplied by 0.1. The actual value is therefore the value of the register multiplied by 10.
Unit	Information unit of measurement: <ul style="list-style-type: none"> "-": no unit corresponding to the value expressed. "h": hours "D": the unit depends on the connected device.
Type	Coding data type (see "Data type" table later in this topic).
Range	Range of permitted values for the variable, usually a subset of what the format allows. For BITMAP type data, the content of this domain is "-".
Default value	Default value for the variable
Svd	Saving the value in the event of a power failure: <ul style="list-style-type: none"> "Y": the value of the register is saved in the event of a power failure. "N": the value is lost in the event of a power failure. <p>NOTE: On start-up or reset, the available values are retrieved.</p>
Function code	Code of functions that can be used in the register.
Description	Information about the register and the restrictions that apply.

Data Types

The following data types appear in the tables of Modbus registers:

Name	Description	Range
UINT	16-bit unsigned integer (1 word)	0...65535
INT	16-bit signed integer (1 word)	-32768...+32767
UINT32	32-bit unsigned integer (2 words)	0...4 294 967 295
INT32	32-bit signed integer (2 words)	-2 147 483 648...+2 147 483 647
Float32	32-bit value (2 words)	-3.4028E+38... +3.4028E+38
ASCII	8-bit alphanumeric character	Table of ASCII Characters
BITMAP	16-bit field (1 word)	-
DATE	See "Date" table later in this topic	-

NOTE:

Float32 type data: Single precision float with sign bit, 8 bits exponent, 23 bits mantissa (positive and negative normalized real)

For ASCII type data, the order of transmission of characters in words (16-bit registers) is as follows:

- Character n as least significant
- Character n + 1 as most significant

All registers (16-bit or 2 bytes) are transmitted with Big Endian coding:

- The most significant byte is transmitted first
- The least significant byte is transmitted second

32-bit variables saved on two 16-bit words (e.g. consumption meters) are in Big Endian format:

- The most significant word is transmitted first, then the least significant.

64-bit variables saved on four 16-bit words (e.g. dates) are in Big Endian format:

- The most significant word is transmitted first, and so on.

DATE

DATE format in accordance with TI081 standard:

Word	Bits																
	15	14	13	12	11	10	9	8	7	6	5	4	3	2	1	0	
1	Reserved (0)								R4 (0)	Year (0...127)							
2	0				Month (1...12)				WD (0)				Day (1...31)				
3	SU (0)	0		Hour (0...23)				iV	0	Minute (0...59)							
4	Millisecond (0...59,999)																
R4:								Bit reserved									
Year:								7 bits (year starting at 2000)									
Month:								4 bits									
Day:								5 bits									
Hour:								5 bits									
Minute:								6 bits									
Millisecond:								16 bits									
WD (day of the week) :								Bit at 0 if this parameter is not used.									
SU (summertime):								Bit at 1 for summertime, bit at 0 if this parameter is not used.									
iV (validity of the information received):								Bit at 1 if the information is not valid, bit at 0 if this parameter is not used.									

Direct Bit Addressing

Addressing is permitted for BITMAP type zones with functions 1, 2, 5 and 15.

The address of the first bit is constructed as follows: (register address x 16) + bit number.

This addressing mode is specific to Schneider Electric.

Example: For functions 1, 2, 5 and 15, bit 3 of register 0x0078 should be addressed; the bit address is therefore 0x0783.

NOTE: The register whose bit needs to be addressed should have an address ≤ 0x0FFF.

Example of Modbus Frames

Request

Definition	Number of Bytes	Value	Comment
Slave number	1 byte	0x05	Acti 9 Smartlink Modbus Address
Function code	1 byte	0x03	Reads n output or internal words
Address	2 bytes	0x36E2	Address of a consumption meter whose address is 14050 in decimal notation.
Number of words	2 bytes	0x002C	Reads 44 16-bit registers.
CRC	2 bytes	xxxx	Value of CRC16.

Response

Definition	Number of Bytes	Value	Comment
Slave number	1 byte	0x05	Acti 9 Smartlink Modbus Address
Function code	1 byte	0x03	Reads n output or internal words
Number of Bytes	2 bytes	0x0058	Number of bytes read
Value of words read	88 bytes	–	Reads 44 16-bit registers
CRC	2 bytes	xxxx	Value of CRC16.

Modbus Address

The list of Modbus addresses, defined by the protocol, starts at 0. The detailed tables in subsequent chapters of this manual give the addresses.

If the programmable controller (Modbus master) refers to the data model addresses, the addresses to be supplied to this controller must meet the following rule: Data model address = address + 1.

If the programmable controller (Modbus master) refers to the protocol addresses, the addresses to be supplied to this controller must be the addresses.

Global Modbus Address Table

Description	Address	No. of Words	Type	RW
System				
Identification	100	11	ASCII	R
Status	112	1	BITMAP	R
Date and Time	115	4	DATE	RW
Summary of channels 1 to 11				
Status	120	2	BITMAP	R
Orders	130	4	BITMAP	RW
Power or flow indicators	14000	44	Float32	R
Consumption meters	14050	44	UINT32	R
Operation counters	14100	44	UINT32	RW
Running hour counters	14144	22	UINT32	RW
Detail of channel 1				
Status	14200	1	BITMAP	R
Orders	14201	2	BITMAP	RW
Output status	14203	1	BITMAP	R
Power or flow indicators	14204	4	Float32	R
Consumption meters	14208	4	UINT32	R
Operation counters	14212	4	UINT32	RW
Running hour counters	14216	2	UINT32	RW
Setting date of operation counters	14218	12	DATE	R
Pulse weight settings (meters)	14230	2	UNIT	RW
Detail of channels 2 to 11				
Channel 2 ⁽¹⁾	14240	40	–	–
Channel 3 ⁽¹⁾	14280	40	–	–
Channel 4 ⁽¹⁾	14320	40	–	–
Channel 5 ⁽¹⁾	14360	40	–	–
Channel 6 ⁽¹⁾	14400	40	–	–
Channel 7 ⁽¹⁾	14440	40	–	–
Channel 8 ⁽¹⁾	14480	40	–	–
Channel 9 ⁽¹⁾	14520	40	–	–
Channel 10 ⁽¹⁾	14560	40	–	–
Channel 11 ⁽¹⁾	14600	40	–	–

⁽¹⁾The detailed information for channels 2 to 11 has the same structure as the detailed information for channel 1. To address the channel N ($1 \leq N \leq 11$) registers, add $40 \times (N - 1)$ to the channel 1 registers.

Modbus Address

The list of Modbus addresses, defined by the Modbus protocol, starts at 0. The detailed tables in subsequent chapters of this manual give the Modbus addresses.

If the programmable controller (Modbus master) refers to the data model addresses, the addresses to be supplied to this controller must meet the following rule: Data model address = Modbus address + 1.

If the programmable controller (Modbus master) refers to the protocol addresses, the addresses to be supplied to this controller must be the Modbus addresses.

Section 9.2

Summary and Detailed Modbus Tables

What Is in This Section?

This section contains the following topics:

Topic	Page
System	79
Summary of Channels 1 to 11	81
Details of Channels 1 to 11	84
Embedded Configuration Registers	90

System

Identification

Address	No.	RW	X	Unit	Type	Range	Default Value	Svd	Function Code	Description
100	6	R	–	–	ASCII	–	N/A	N	03, 100–4	Serial number on 12 ASCII characters; 11 alphanumeric digits maximum [SN] or [S/N]: PP YY WW [D[nnnn]] <ul style="list-style-type: none"> ● PP: SAP Bridge plant number ● YY: Year in decimal notation [05...99] ● WW: Week in decimal notation [1...53] ● D: Day of the week in decimal notation [1...7] ● nnnn: Sequence of numbers [0001...10.000–1]
109	3	R	–	–	ASCII	–	N/A	N	03, 100–4	Software version on 6 ASCII characters. Example: “V0.0.1”

Status

Address	No.	RW	X	Unit	Type	Range	Default Value	Svd	Function Code	Description
112	1	R	–	–	BITMAP	–	0x0000	N	01, 02, 03, 100–4	Acti 9 Smartlink device status and diagnostic register Bit 0 = 1: start-up phase Bit 1 = 1: operating phase Bit 2 = 1: downgraded mode ⁽¹⁾ Bit 3 = 1: failure mode Bit 4: not used Bit 5: not used Bit 6 = 1: invalid data Bit 7 = 1: invalid 24 V I/O Bit 8: not used Bit 9: not used Bit 10: not used Bit 11: not used Bit 12: not used Bit 13: E2PROM error Bit 14: RAM error Bit 15: FLASH error NOTE: Bits 0 to 3 are exclusive: only one mode is used at any given time.

⁽¹⁾Downgraded mode comes into effect:

- When the power supply is cut or less than 16 V DC.
- In the event of overcurrent (overload or short-circuit) on the Ti24 I/O.

If a short-circuit on an output has caused a change to downgraded mode, at the end of the short-circuit, the output is reset to 0 by the electronics: the Modbus master system sends a Modbus message to reset the output to 1 if it was at 1, before the short-circuit.

Failure mode intervenes if there is an FLASH and/or RAM and/or E2PROM error.

The data is invalid in the start-up phase, downgraded and failure modes. Invalid data include inputs 1 and 2, the power or flow indicator, the operation and running hours counter.

- The E2PROM error bit is activated during the operating phase when a checksum error is detected in an E2PROM page.
- The RAM error bit is activated during the product initialization phase when an error is detected during a test of the RAM.
- The FLASH error bit is activated during the start-up phase when a checksum error is detected on the FLASH memory.

Date and Time

Address	No.	RW	X	Unit	Type	Range	Default Value	Svd	Function Code	Description
115	4	RW	-	-	DATE	(1)	N/A	N	03, 16 100-4	Indicates the year, month, day, hour, minute and millisecond on the Acti 9 Smartlink device.

(1) See description of the DATE type ([see page 75](#)).

Summary of Channels 1 to 11

Status

Address	No.	RW	X	Unit	Type	Range	Default Value	Svd	Function Code	Description
120	1	R	–	–	BITMAP	–	0x0000	N	01, 02, 03, 100–4	Electrical status on input 1 of all channels ⁽¹⁾ .
121	1	R	–	–	BITMAP	–	0x0000	N	01, 02, 03, 100–4	Electrical status on input 2 of all channels ⁽¹⁾ .

(1)

- Bit 0 to 10: channel 1 to 11
- Bits 11 to 15: reserved

Each bit gives the electrical level of input 1 and 2:

- 0 = no current
- 1 = input current

Reserved bits do not mean anything.

Orders

Address	No.	RW	X	Unit	Type	Range	Default Value	Svd	Function Code	Description
130	1	RW	–	–	BITMAP	–	0x0000	N	01, 02, 03, 05, 06, 15, 16, 100–4	Open order for Acti 9 product ⁽¹⁾ .
131	1	RW	–	–	BITMAP	–	0x0000	N	01, 02, 03, 05, 06, 15, 16, 100–4	Close order for Acti 9 product ⁽¹⁾ .
132	1	RW	–	–	BITMAP	–	0x0000	N	01, 02, 03, 05, 06, 15, 16, 100–4	Deactivation order for product not in the Acti 9 range ⁽¹⁾ .
133	1	RW	–	–	BITMAP	–	0x0000	N	01, 02, 03, 05, 06, 15, 16, 100–4	Activation order for product not in the Acti 9 range ⁽¹⁾ .

(1)

- Bit 0 to 10: channel 1 to 11
- Bits 11 to 15: reserved

NOTE:

- Each bit corresponds to an open order (activated when the bit is at 1).
- The open order on several channels is possible.
- The Acti 9 Smartlink device resets the bit to state 0 when the order is taken into account (unless no product is connected to the channel).
- If a reserved bit is at 1, the Acti 9 Smartlink device resets it to 0.
- “No meaning” indicates that the bits are fixed at 0 or 1 and do not affect the system.
- If bits 0 and 1 are at 1, there is no effect on the system.

Power or Flow Indicators

	Channels										
	1	2	3	4	5	6	7	8	9	10	11
Input I1	14000	14002	14004	14006	14008	14010	14012	14014	14016	14018	14020
Input I2	14022	14024	14026	14028	14030	14032	14034	14036	14038	14040	14042

Address	No.	RW	X	Unit	Type	Range	Default Value	Svd	Function Code	Description
14000	2	R	X1	D	Float32	–	0	N	03, 100–4	Power or flow indicator for channel 1/input 1 ⁽¹⁾ .

(1)

- When the impulse counter (the unit depends on the connected device: energy, gas, water, etc.) is connected to input 1 or 2 of channel 1, the register contains the flow value. This is calculated as follows:
 - $(3600 \times \text{pulse weight})/t$, t representing the time in seconds between 2 pulses. The result is expressed for one hour.
- The pulse weight is 10 by default and can be configured by the Modbus command.

Example: This register indicates the active power between the last 2 pulses if an iEM2000T device is connected to the channel 1/input 1 (Pulse weight = 10 Wh).

NOTE:

This register is reset to 0:

- After a duration $d = 3 \times t$ (t being the time in seconds between the last 2 pulses), if $3 \times t$ is less than 5 seconds, the duration d equals 5 seconds
- After 24 hours without a pulse
- After loss of the 24 Vdc input/output voltage

The accuracy of the power or flow indication is:

- 5% if the pulse frequency is 5 Hertz or less
- 17% if the pulse frequency equals the maximum frequency of 17 Hertz

Consumption Meters

The consumption meters in this Modbus table indicate the consumption from meters connected to each Acti 9 Smartlink channel (1 to 11).

The consumption value (associated with a channel) is obtained by multiplying the number of pulses (received by inputs I1 and I2 of this channel) by the pulse weight.

	Channels										
	1	2	3	4	5	6	7	8	9	10	11
Input I1	14050	14052	14054	14056	14058	14060	14062	14064	14066	14068	14070
Input I2	14072	14074	14076	14078	14080	14082	14084	14086	14088	14090	14092

Address	No.	RW	X	Unit	Type	Range	Default Value	Svd	Function Code	Description
14050	2	R	X1	–	UINT32	–	0	Y	03, 100–4	Consumption meter on channel 1/input I1.

NOTE:

- The number of pulses from inputs I1 and I2 of each channel (1 to 11) are available in registers 14212 (channel 1) to 14614 (channel 11). The number of pulses can be preset by writing to the impulse counter register. See the Operation Counters chapter.
- The pulse weights of inputs I1 and I2 of each channel (1 to 11) are available and can be set in registers 14230 (channel 1) to 14631 (channel 11). The pulse weight is 10 by default. See the Parameter Settings chapter.

Operation Counters

	Channels										
	1	2	3	4	5	6	7	8	9	10	11
Input I1	14100	14102	14104	14106	14108	14110	14112	14114	14116	14118	14120
Input I2	14122	14124	14126	14128	14130	14132	14134	14136	14138	14140	14142

Address	No.	RW	X	Unit	Type	Range	Default Value	Svd	Function Code	Description
14100	2	RW	X1	–	UINT32	–	0	Y	03, 16, 100–4	Operation counter for channel 1/input 1: changes from state 1 to state 0.

Running Hour Counters

	Channels										
	1	2	3	4	5	6	7	8	9	10	11
Input I1	14144	14146	14148	14150	14152	14154	14156	14158	14160	14162	14164

Address	No.	RW	X	Unit	Type	Range	Default Value	Svd	Function Code	Description
14144	2	RW	X1	h	UINT32	–	0	Y	03, 16, 100–4	Running hours counter for channel 1/input 1. Counting starts when the input is activated.

Details of Channels 1 to 11

Channels 1 to 11 Overview

	Channels										
	1	2	3	4	5	6	7	8	9	10	11
Status											
Input I1 (bit 0)	14200	14240	14280	14320	14360	14400	14440	14480	14520	14560	14600
Input I2 (bit 1)	14200	14240	14280	14320	14360	14400	14440	14480	14520	14560	14600
Orders											
Commands output Q (bit 0 and bit 1): Acti 9 product	14201	14241	14281	14321	14361	14401	14441	14481	14521	14561	14601
Commands output Q (bit 0 and bit 1): non-Acti 9 product	14202	14242	14282	14322	14362	14402	14442	14482	14522	14562	14602
State of output Q (bit 0)	14203	14243	14283	14323	14363	14403	14443	14483	14523	14563	14603
Counters											
Input I1 power or flow indicator ⁽²⁾	14204	14244	14284	14324	14364	14404	14444	14484	14524	14564	14604
Input I2 power or flow indicator ⁽²⁾	14206	14246	14286	14326	14366	14406	14446	14486	14526	14566	14606
Input I1 consumption meter ⁽¹⁾⁽²⁾	14208	14248	14288	14328	14368	14408	14448	14488	14528	14568	14608
Input I2 consumption meter ⁽¹⁾⁽²⁾	14210	14250	14290	14330	14370	14410	14450	14490	14530	14570	14610
Operation and Running Hours Counters											
I1 operation counter ⁽¹⁾	14212	14252	14292	14332	14372	14412	14452	14492	14532	14572	14612
I2 operation counter ⁽¹⁾	14214	14254	14294	14334	14374	14414	14454	14494	14534	14574	14614
I1 input running hours ⁽¹⁾	14216	14256	14296	14336	14376	14416	14456	14496	14536	14576	14616
Setting Date of Operation Counters											
Input I1 date	14218	14258	14298	14338	14378	14418	14458	14498	14538	14578	14618
Input I2 date	14222	14262	14302	14342	14382	14422	14462	14502	14542	14582	14622
Running hours parameter setting date on input I1	14226	14266	14306	14346	14386	14426	14466	14506	14546	14586	14626
Pulse Weight Settings (Meters)											
Pulse weight for input I1 ⁽²⁾	14230	14270	14310	14350	14390	14430	14470	14510	14550	14590	14630
Pulse weight for input I2 ⁽²⁾	14231	14271	14311	14351	14391	14431	14471	14511	14551	14591	14631

⁽¹⁾ Data type: UINT32

⁽²⁾ Information specific to Meter type devices

Modbus Address

The list of Modbus addresses, defined by the Modbus protocol, starts at 0. The detailed tables in subsequent chapters of this manual give the Modbus addresses.

If the programmable controller (Modbus master) refers to the data model addresses, the addresses to be supplied to this controller must meet the following rule: Data model address = Modbus address + 1.

If the programmable controller (Modbus master) refers to the protocol addresses, the addresses to be supplied to this controller must be the Modbus addresses.

Reminder: The following figure shows the terminals for each channel.

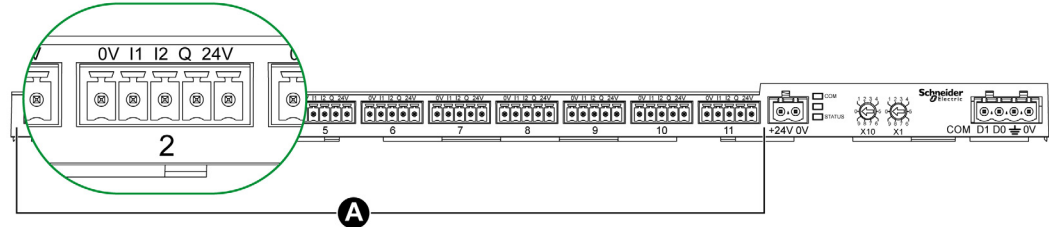

A Channels from 1 to 11

Description of Terminals for Each Channel (Ti24 Interface):

Terminal	Description
24 V	24 V of the 24 Vdc power supply
Q	Control output
I2	Input number 2
I1	Input number 1
0 V	0 V of the 24 Vdc power supply

Status

	Channels										
	1	2	3	4	5	6	7	8	9	10	11
Input I1 (bit 0)	14200	14240	14280	14320	14360	14400	14440	14480	14520	14560	14600
Input I2 (bit 1)	14200	14240	14280	14320	14360	14400	14440	14480	14520	14560	14600

Address	No.	RW	X	Unit	Type	Range	Default Value	Svd	Function Code	Description
14200	1	R	-	-	BITMAP	-	0x0000	N	03, 100-4	Electrical status of inputs 1 and 2 of all connected devices ⁽¹⁾ .

(1)

- Bit 0 = electrical level of input 1
- Bit 1 = electrical level of input 2
- Bits 2 to 15 = reserved

NOTE: "Reserved" means that the bits are fixed at 0 and do not mean anything.

Meaning of bits for inputs I1 and I2:

- 0 = no current
- 1 = input current

Orders

	Channels										
	1	2	3	4	5	6	7	8	9	10	11
Output Q (bit 0 and bit 1): Acti 9 product	14201	14241	14281	14321	14361	14401	14441	14481	14521	14561	14601

Address	No.	RW	X	Unit	Type	Range	Default Value	Svd	Function Code	Description
14201	1	RW	–	–	BITMAP	–	0x0000	N	03, 06, 16, 100–4	Close and open order for products in the Acti 9 range ⁽¹⁾ .

	Channels										
	1	2	3	4	5	6	7	8	9	10	11
Output Q (bit 0 and bit 1): non-Acti 9 product	14202	14242	14282	14322	14362	14402	14442	14482	14522	14562	14602

Address	No.	RW	X	Unit	Type	Range	Default Value	Svd	Function Code	Description
14202	1	RW	–	–	BITMAP	–	0x0000	N	03, 06, 16, 100–4	Deactivation and activation order for product not in the Acti 9 range ⁽²⁾ .

(1)

- Bit 0 = close order
- Bit 1 = open order
- Bits 2 to 15 = no meaning

(2)

- Bit 0 = deactivation order
- Bit 1 = activation order
- Bits 2 to 15 = no meaning

NOTE:

- The Acti 9 Smartlink device resets the bit to state 0 when the order is taken into account (unless no product is connected to the channel).
- If a reserved bit is at 1, the Acti 9 Smartlink device resets it to 0.
- “No meaning” indicates that the bits are fixed at 0 or 1 and do not affect the system.
- If bits 0 and 1 are at 1, there is no effect on the system.

Power or Flow Indicators

	Channels										
	1	2	3	4	5	6	7	8	9	10	11
Input I1 power or flow indicator ⁽⁶⁾	14204	14244	14284	14324	14364	14404	14444	14484	14524	14564	14604
Input I2 power or flow indicator ⁽⁶⁾	14206	14246	14286	14326	14366	14406	14446	14486	14526	14566	14606

Address	No.	RW	X	Unit	Type	Range	Default Value	Svd	Function Code	Description
14204	2	R	X1	D	Float32	–	0	N	03, 100–4	Power or flow indicator for input 1 ⁽¹⁾ .
14206	2	R	X1	D	Float32	–	0	N	03, 100–4	Power or flow indicator for input 2 ⁽¹⁾ .

⁽¹⁾ The same channel (Ti24 interface) on the Acti 9 Smartlink can take account of 2 counters:

- One counter connected to input I1
- One counter connected to input I2

Consumption Meters

	Channels										
	1	2	3	4	5	6	7	8	9	10	11
Input I1 consumption meter ⁽¹⁾	14208	14248	14288	14328	14368	14408	14448	14488	14528	14568	14608
Input I2 consumption meter ⁽¹⁾	14210	14250	14290	14330	14370	14410	14450	14490	14530	14570	14610

⁽¹⁾ The same channel (Ti24 interface) on the Acti 9 Smartlink can take account of 2 meters:

- One meter connected to input I1
- One meter connected to input I2

Address	No.	RW	X	Unit	Type	Range	Default Value	Svd	Function Code	Description
14208	2	R	X1	–	UINT32	–	0	Y	03, 100–4	Consumption meter on input 1.
14210	2	R	X1	–	UINT32	–	0	Y	03, 100–4	Consumption meter on input 2.

Operation Counters

	Channels										
	1	2	3	4	5	6	7	8	9	10	11
I1 operation counter	14212	14252	14292	14332	14372	14412	14452	14492	14532	14572	14612
I2 operation counter	14214	14254	14294	14334	14374	14414	14454	14494	14534	14574	14614

Address	No.	RW	X	Unit	Type	Range	Default Value	Svd	Function Code	Description
14212	2	RW	X1	–	UINT32	–	0	Y	03, 16 100–4	Operation counter for channel 1/input 1. This register indicates the number of changes of state of input 1 from state 1 to state 0.

Running Hour Counters

	Channels										
	1	2	3	4	5	6	7	8	9	10	11
I1 input running time	14216	14256	14296	14336	14376	14416	14456	14496	14536	14576	14616

Address	No.	RW	X	Unit	Type	Range	Default Value	Svd	Function Code	Description
14216	2	RW	X1	h	UINT32	–	0	Y	03, 16 100–4	Running hours counter for channel 1/input 1. Counting starts when the input is activated.

Setting Date of Operation Counters

	Channels										
	1	2	3	4	5	6	7	8	9	10	11
Input I1 date	14218	14258	14298	14338	14378	14418	14458	14498	14538	14578	14618
Input I2 date	14222	14262	14302	14342	14382	14422	14462	14502	14542	14582	14622
Running hours parameter setting date on input I1	14226	14266	14306	14346	14386	14426	14466	14506	14546	14586	14626

Address	No.	RW	X	Unit	Type	Range	Default Value	Svd	Function Code	Description
14218	4	R	–	–	DATE	(1)	(1)	Y	03, 100–4	Date when the operation counter parameter was last set. This register indicates the date and time when the operation counter parameter was last set on input 1.
14222	4	R	–	–	DATE	(1)	(1)	Y	03, 100–4	Date when the operation counter parameter was last set. This register indicates the date and time when the operation counter parameter was last set on input 2.
14226	4	R	–	–	DATE	(1)	(1)	Y	03, 100–4	Date when the running hours counter parameter was last set. This register indicates the date and time when the running hours counter parameter was last set on input 1.

(1) See description of the DATE type ([see page 75](#)).

Pulse Weight Settings (Meters)

	Channels										
	1	2	3	4	5	6	7	8	9	10	11
Pulse weight I1	14230	14270	14310	14350	14390	14430	14470	14510	14550	14590	14630
Pulse weight I2 ⁽¹⁾	14231	14271	14311	14351	14391	14431	14471	14511	14551	14591	14631

Address	No.	RW	X	Unit	Type	Range	Default Value	Svd	Function Code	Description
14230	1	RW	X1	D	UNIT	0...65,535	10	Y	03, 06, 16 100-4	Pulse weight: this register can be used to set the value of the pulse weight for the meter connected to input 1 of channel 1.
14231	1	RW	X1	D	UNIT	0...65,535	10	Y	03, 06, 16 100-4	Pulse weight: this register can be used to set the value of the pulse weight for the meter connected to input 2 of channel 1.

⁽¹⁾ The same channel (Ti24 interface) on the Acti 9 Smartlink can take account of 2 meters:

- One meter connected to input I1
- One meter connected to input I2

Embedded Configuration Registers

Details of Digital Channels 1 to 11

	Channels										
	1	2	3	4	5	6	7	8	9	10	11
Input I1	20009	20137	20265	20393	20521	20649	20777	20905	21033	21161	21289
Input I2	20073	20201	20329	20457	20585	20713	20841	20969	21097	21225	21353
Output	21417	21481	21545	21609	21673	21737	21801	21865	21929	21993	22057

Address	No.	RW	X	Unit	Type	Range	Default Value	Svd	Function Code	Description
20009	13	R	-	-	ASCII	-	-	Y	03, 100-4	User-defined name of the device (maximum 20 bytes and minimum 0 byte).
20022	13	R	-	-	ASCII	-	-	Y	-	User-defined label of the device (maximum 5 bytes and minimum 0 byte).
20035	1	R	-	-	UINT16	-	-	Y	-	Indicates the product type. 0 = Null 1 = Standard IO 2 = Standard counter (any pulse meter) 3 = OF+SD24 (breaker with status) 4 = iOF+SD24 (breaker with status) 5 = Reflex iC60 (breaker with control) 6 = RCAiC60 (breaker with control) 7 = iACT24 (contactor) 8 = iATL24 (relay) 10 = PM3210 12 = PM3255 13 = iEM3110 15 = iEM3155 16 = iEM3210 18 = iEM3255 18 = iEM3255 19 = iEM2000T 25 = Breaker IO 27 = iEM3355
20036	1	R	-	-	UINT16	-	10	Y	-	Indicates the pulse weight from 0...65535.
20037	1	R	-	-	UINT16	-	-	Y	-	Indicates the unit of the device. 0 = Wh 2 = M3 3 = L 4 = J 5 = Cal 8 = Gallon

NOTE: The above table provides the description of embedded configuration registers of the digital channels and it is read-only registers.

Section 9.3

Modbus Tables for Connected Products

What Is in This Section?

This section contains the following topics:

Topic	Page
iOF+SD24 Indication Auxiliary	92
OF+SD24 Indication Auxiliary	93
iEM2000T, iEM3110, iEM3155, iEM3210, iEM3255, iEM3355 Meters or Meter with Pulse Output (Standard CEI 62053-31)	94
iACT24 Auxiliary for iCT Contactor	95
iATL24 Auxiliary for iTL Impulse Relay	96
Contactor and Relay (Not in the Acti 9 Range)	97
Acti 9 RCA iC60 Remote Control with Ti24 Interface	98
Acti 9 Reflex iC60 Integrated Control Circuit Breaker With Ti24 Interface	99

iOF+SD24 Indication Auxiliary

Overview

The iOF+SD24 indication auxiliary is used to find out the status of the following devices:

- iC60 and iC65 circuit breaker (OF and \overline{SD} states)
- iID residual current circuit breaker (OF and \overline{SD} states)
- iSW-NA switch (OF status)
- iDPN circuit breaker (sold in China)

The Modbus information in the following table is given for an iOF+SD24 auxiliary connected to channel 1.

Description	Address ⁽¹⁾	No. of Register(s)	Type	Action	Values and Meanings
Status					
OF status	14200	1	BITMAP	R	bit 0 = 0: circuit breaker open bit 0 = 1: circuit breaker closed
status \overline{SD}	14200	1	BITMAP	R	bit 1 = 0: device tripped (fault present) bit 1 = 1: device not tripped
Counters					
Number of circuit breaker opening/closing cycles	14212	2	UINT32	RW	–
Number of trippings	14214	2	UINT32	RW	–
Load running time	14216	2	UINT32	RW	in hours

⁽¹⁾ To address the channel N ($1 \leq N \leq 11$) registers, add $40 \times (N - 1)$ to the channel 1 registers.

OF+SD24 Indication Auxiliary

Overview

The OF+SD24 indication auxiliary is used to find out the status of the following devices:

- C60 or C120 circuit breaker (OF and \overline{SD} states)
- DPN residual current circuit breaker (OF and \overline{SD} states)
- DPN switch (OF status)
- C60H-DC circuit breaker (OF and \overline{SD} states)
- iDPN circuit breaker (sold in every country except China)

The Modbus information in the following table is given for an OF+SD24 auxiliary connected to channel 1.

Description	Address ⁽¹⁾	No. of Register(s)	Type	Action	Values and Meanings
Status					
OF status	14200	1	BITMAP	R	bit 0 = 0: circuit breaker open bit 0 = 1: circuit breaker closed
status \overline{SD}	14200	1	BITMAP	R	bit 1 = 0: device tripped (fault present) bit 1 = 1: device not tripped
Counters					
Number of circuit breaker opening/closing cycles	14212	2	UINT32	RW	–
Number of trippings	14214	2	UINT32	RW	–
Load running time	14216	2	UINT32	RW	in hours

⁽¹⁾ To address the channel N ($1 \leq N \leq 11$) registers, add $40 \times (N - 1)$ to the channel 1 registers.

iEM2000T, iEM3110, iEM3155, iEM3210, iEM3255, iEM3355 Meters or Meter with Pulse Output (Standard CEI 62053-31)

Overview

The meter delivers a pulse output.

The Modbus information in the following table is given for a meter connected to channel 1.

The same channel (Ti24 interface) on the Acti 9 Smartlink can take account of 2 meters:

- One meter connected to input I1
- One meter connected to input I2

Description	Address ⁽¹⁾	No. of Register(s)	Type	Action	Values and Meanings
Status					
Pulse output (meter 1)	14200	1	BITMAP	R	bit 0
Pulse output (meter 2)	14200	1	BITMAP	R	bit 1
Counters					
Power or flow indicator (meter 1)	14204	2	Float32	R	(2)
Power or flow indicator (meter 2)	14206	2	Float32	R	(2)
Consumption meter (meter 1)	14208	2	UINT32	R	(3)
Consumption meter (meter 2)	14210	2	UINT32	R	(3)
Settings					
Pulse weight (meter 1)	14230	1	UINT	RW	(2)
Pulse weight (meter 2)	14231	1	UINT	RW	(2)

⁽¹⁾ To address the channel N (1 ≤ N ≤ 11) registers, add 40 × (N – 1) to the channel 1 registers.

⁽²⁾ The register contains the flow value.

- The flow is: (3600 x pulse weight)/t, with t representing the time in seconds between two pulses. The result is expressed for one hour.
- The pulse weight is 10 by default. The unit depends on the connected device: energy, gas, water, etc.

⁽³⁾ The consumption value (associated with a channel) is obtained by multiplying the number of pulses (received by inputs I1 and I2 of this channel) by the pulse weight.

iACT24 Auxiliary for iCT Contactor

Overview

The iACT24 auxiliary:

- Can be used to control an iCT contactor rated 25 A or higher via its Y1, Y2 and Y3 inputs.
The Y3 (24 Vdc) input can be controlled by one of the Acti 9 Smartlink device channels.
- Is used to find out the contactor status (O/C status: open/closed status)

The Modbus information in the following table is given for an iACT24 auxiliary connected to channel 1.

Description	Address ⁽¹⁾	No. of Register(s)	Type	Action	Values and Meanings
Status					
O/C status: open/closed status	14200	1	BITMAP	R	bit 0 = 0: contactor open bit 0 = 1: contactor closed
Device present	14200	1	BITMAP	R	bit 1 = 0: connection fault or no connected device bit 1 = 1: connected device
Orders					
Deactivate contactor coil	14201	1	BITMAP	RW	bit 0 = 1: deactivate coil ⁽²⁾
Activate contactor coil	14201	1	BITMAP	RW	bit 1 = 1: activate coil ⁽²⁾
Counters					
Number of contactor open/close cycles	14212	2	UINT32	RW	–
Load running time for an NO contactor	14216	2	UINT32	RW	in hours

⁽¹⁾ To address the channel N ($1 \leq N \leq 11$) registers, add $40 \times (N - 1)$ to the channel 1 registers.

⁽²⁾ The Acti 9 Smartlink device resets the bit to state 0 when the order is taken into account (unless no product is connected to the channel). If bits 0 and 1 of address 14201 are activated simultaneously, the Acti 9 Smartlink device does nothing.

iATL24 Auxiliary for iTL Impulse Relay

Overview

The iATL24 auxiliary:

- Can be used to control an iTL impulse relay via its Y1, Y2 and Y3 inputs
The Y3 (24 Vdc) input can be controlled by one of the Acti 9 Smartlink device channels.
- Can be used to find out the impulse relay status (O/C status open/closed status).

The Modbus information in the following table is given for an iATL24 auxiliary connected to channel 1.

Description	Address ⁽¹⁾	No. of Register(s)	Type	Action	Values and Meanings
Status					
O/C status: open/closed status	14200	1	BITMAP	R	bit 0 = 0: impulse relay open bit 0 = 1: impulse relay closed
Device present	14200	1	BITMAP	R	bit 1 = 0: connection fault or no connected device bit 1 = 1: connected device
Orders					
Impulse relay contact opening	14201	1	BITMAP	RW	bit 0 = 1: Impulse relay contact opening ⁽²⁾
Impulse relay contact closing	14201	1	BITMAP	RW	bit 1 = 1: Impulse relay contact closing ⁽²⁾
Counters					
Number of impulse relay opening/closing cycles	14212	2	UINT32	RW	–
Load running time	14216	2	UINT32	RW	in hours

⁽¹⁾ To address the channel N ($1 \leq N \leq 11$) registers, add $40 \times (N - 1)$ to the channel 1 registers.

⁽²⁾ The Acti 9 Smartlink device resets the bit to state 0 when the order is taken into account (unless no product is connected to the channel). If bits 0 and 1 of address 14201 are activated simultaneously, the Acti 9 Smartlink device does nothing.

Contactor and Relay (Not in the Acti 9 Range)

Overview

A contactor or relay powered with 24 Vdc can be connected to Acti 9 Smartlink. This should have the following characteristics:

- The contactor or relay coil must not draw more than 100 mA
- The indication contact must be low level type

Only contactors in the Acti 9 range can be connected to Acti 9 Smartlink using the iATL24 auxiliary.

The contactor can be controlled by one of the Acti 9 Smartlink device channels.

The Modbus information in the following table is given for a contactor connected to channel 1.

Description	Address ⁽¹⁾	No. of Register(s)	Type	Action	Values and Meanings
Status					
OF status	14200	1	BITMAP	R	bit 0 = 0: contactor open bit 0 = 1: contactor closed
Orders					
Deactivate contactor coil	14202	1	BITMAP	RW	bit 0 = 1: deactivate coil ⁽²⁾
Activate contactor coil	14202	1	BITMAP	RW	bit 1 = 1: activate coil ⁽²⁾
Counters					
Number of contactor open/close cycles	14212	2	UINT32	RW	–
Load running time for an NO contactor	14216	2	UINT32	RW	in hours

⁽¹⁾ To address the channel N ($1 \leq N \leq 11$) registers, add $40 \times (N - 1)$ to the channel 1 registers.

⁽²⁾ The Acti 9 Smartlink device resets the bit to state 0 when the order is taken into account (unless no product is connected to the channel). If bits 0 and 1 of address 14202 are activated simultaneously, the Acti 9 Smartlink device does nothing.

Acti 9 RCA iC60 Remote Control with Ti24 Interface

Overview

The Acti 9 RCA iC60 remote control:

- Should have a Ti24 interface (with product references A9C70122 and A9C70124)
- Can be used to control a iC60 circuit breaker via input Y3 of its Ti24 interface.
The Y3 (24 Vdc) input can be controlled by one of the Acti 9 Smartlink device channels
- Can be used to find out the OF and \overline{SD} states of the circuit breaker associated with the Acti 9 RCA iC60 remote control

The Modbus information in the following table is given for an Acti 9 RCA iC60 remote control connected to channel 1.

Description	Address ⁽¹⁾	No. of Register(s)	Type	Action	Values and Meanings
Status					
OF status	14200	1	BITMAP	R	bit 0 = 0: circuit breaker open bit 0 = 1: circuit breaker closed
status \overline{SD}	14200	1	BITMAP	R	bit 1 = 0: device tripped (fault present) bit 1 = 1: device not tripped
Orders					
Activation of the open order	14201	1	BITMAP	RW	bit 0 = 1: activation of the open order ⁽²⁾
Activation of the close order	14201	1	BITMAP	RW	bit 1 = 1: activation of the close order ⁽²⁾
Counters					
Number of circuit breaker open/close cycles	14212	2	UINT32	RW	–
Number of trippings	14214	2	UINT32	RW	–
Load running time	14216	2	UINT32	RW	in hours

⁽¹⁾ To address the channel N ($1 \leq N \leq 11$) registers, add $40 \times (N - 1)$ to the channel 1 registers.

⁽²⁾ The Acti 9 Smartlink device resets the bit to state 0 when the order is taken into account (unless no product is connected to the channel). If bits 0 and 1 of address 14201 are activated simultaneously, the Acti 9 Smartlink device does nothing.

Acti 9 Reflex iC60 Integrated Control Circuit Breaker With Ti24 Interface

Overview

The Acti 9 Reflex iC60 integrated control circuit breaker:

- Should have a Ti24 interface (with product references A9C6****).
- Can allow the device to be controlled via input Y3 of its Ti24 interface
The Y3 (24 Vdc) input can be controlled by one of the Acti 9 Smartlink device channels.
- Can be used to communicate its O/C and auto/OFF status

The Modbus information in the following table is given for an Acti 9 Reflex iC60 integrated control circuit breaker connected to channel 1.

Description	Address ⁽¹⁾	No. of Register(s)	Type	Action	Values and Meanings
Status					
O/C status: open/closed status	14200	1	BITMAP	R	bit 0 = 0: circuit breaker open bit 0 = 1: circuit breaker closed
auto/OFF status: handle position	14200	1	BITMAP	R	bit 1 = 0: handle in OFF position (device open) bit 1 = 1: handle in upper position: auto
Orders					
Activation of the open order	14201	1	BITMAP	RW	bit 0 = 1: activation of the open order ⁽²⁾
Activation of the close order	14201	1	BITMAP	RW	bit 1 = 1: activation of the close order ⁽²⁾
Counters					
Number of circuit breaker open/close cycles	14212	2	UINT32	RW	–
Number of trippings	14214	2	UINT32	RW	–
Load running time	14216	2	UINT32	RW	in hours

⁽¹⁾ To address the channel N ($1 \leq N \leq 11$) registers, add $40 \times (N - 1)$ to the channel 1 registers.

⁽²⁾ The Acti 9 Smartlink device resets the bit to state 0 when the order is taken into account (unless no product is connected to the channel). If bits 0 and 1 of address 14201 are activated simultaneously, the Acti 9 Smartlink device does nothing.

Chapter 10

Integration of Acti 9 Smartlink in an EGX System

What Is in This Chapter?

This chapter contains the following topics:

Topic	Page
Introduction to the EGX System	102
Connection	103
Configuration	105
Control	109
Monitoring	111
Diagnostics	114

Introduction to the EGX System

Overview

For Acti 9 Smartlink, the EGX300 gateway (version 4.200 or later) can be used in two different ways:

- Standard gateway function (see document EGX 63230-319-216B2 dated 11/2011)
- Function with Web Server page embedded in EGX300 and adapted for Acti 9 Smartlink

With the embedded Web Server page function, you can:

- View the discrete I/O status
- Set the energy meter parameters
- View energy consumption in the form of a graph (curves)
- Export the consumption data stored in the EGX300 in .csv format
- View the Modbus registers of Acti 9 Smartlink devices

The following chapters describe configuration and the functions accessible in the embedded Web Server for Acti 9 Smartlink.

After configuring the EGX300 gateway Ethernet parameters, you can access the EGX300 gateway on a local area network, using a standard Web browser.

The following diagram shows the home page:

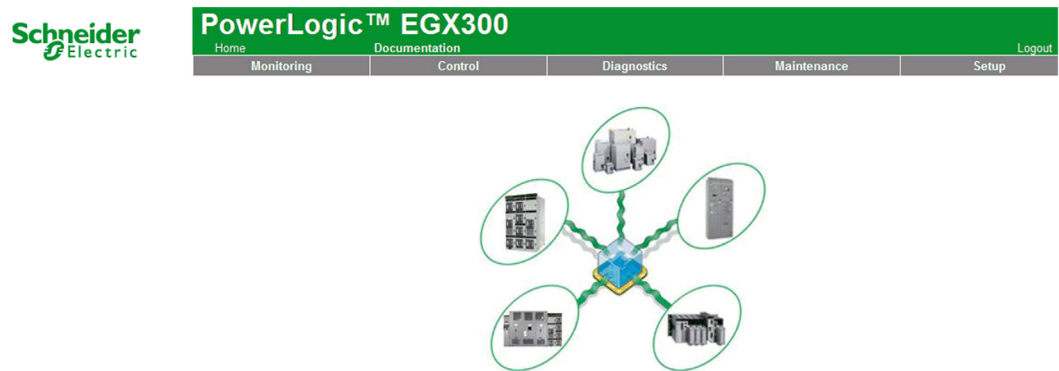

To close the EGX300 session, click **Logout**.

We recommend that you log out when you no longer need to access the EGX300 gateway.

Connection

Possible Connections

The first operation consists of connecting the Acti 9 Smartlink device(s) to the EGX gateway.
The following figure shows the options for connecting devices on EGX:

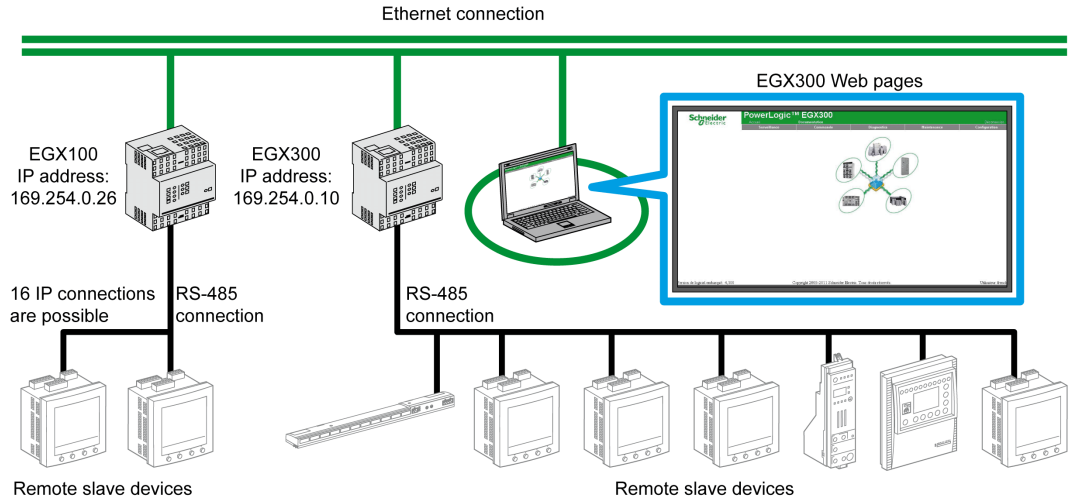

The Acti 9 Smartlink device can be connected as a serial slave device or as a remote slave device.

Selector Switch Position

The EGX gateway selector switches must be configured for operation on a two-wire network.
The following figure shows the required selector switch configuration:

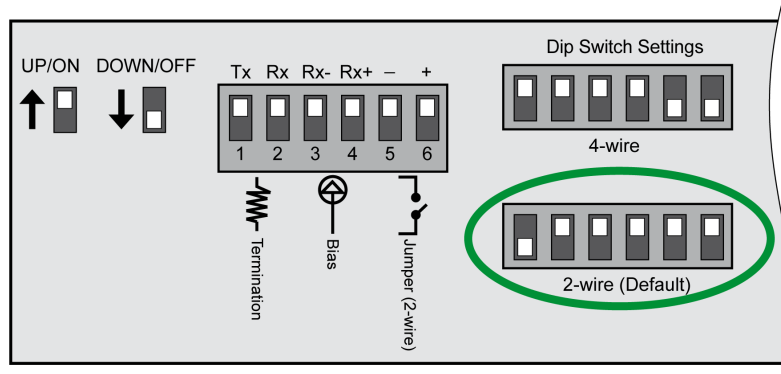

Wiring

The link used between the EGX gateway and the Acti 9 Smartlink device(s) is a two-wire link plus an earthing braid.

The physical connection between the EGX connector and the Modbus connectors on Acti 9 Smartlink devices must be made as follows:

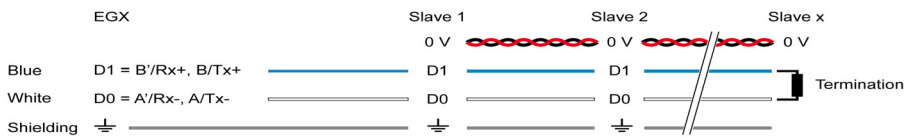
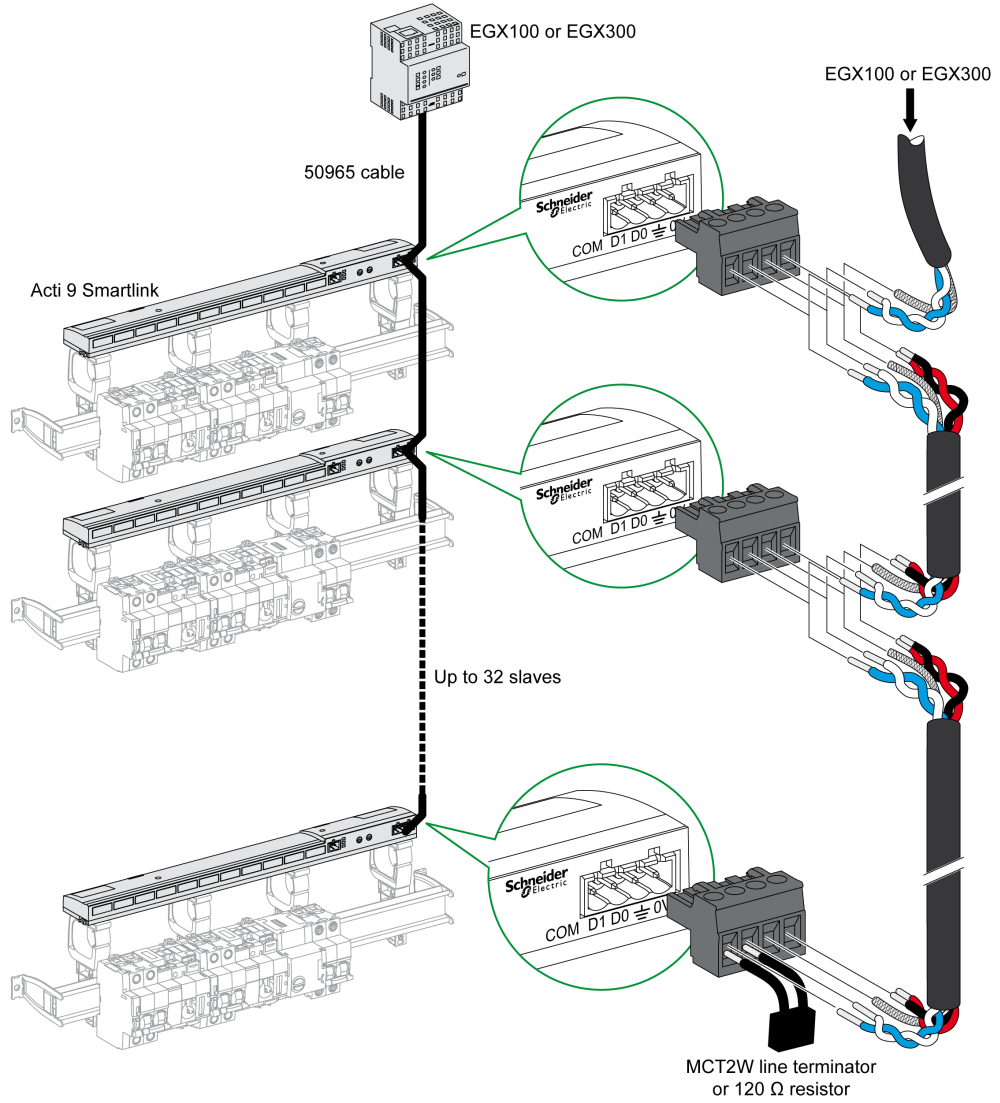

Configuration

Device List

The **Device List** page can be used to detect and configure devices connected to the EGX300 gateway. To go to this page, select the **Configuration** tab, then click on **Device List** on the left of the screen. The following illustration shows the **Device List** page:

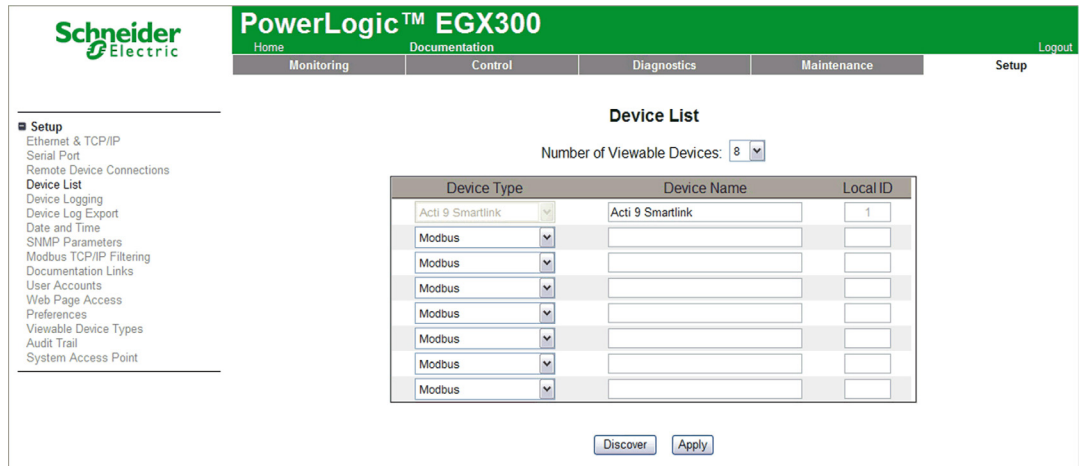

Automatic Detection

From the **Device List** page, click the **Detection** button. The following page will appear:

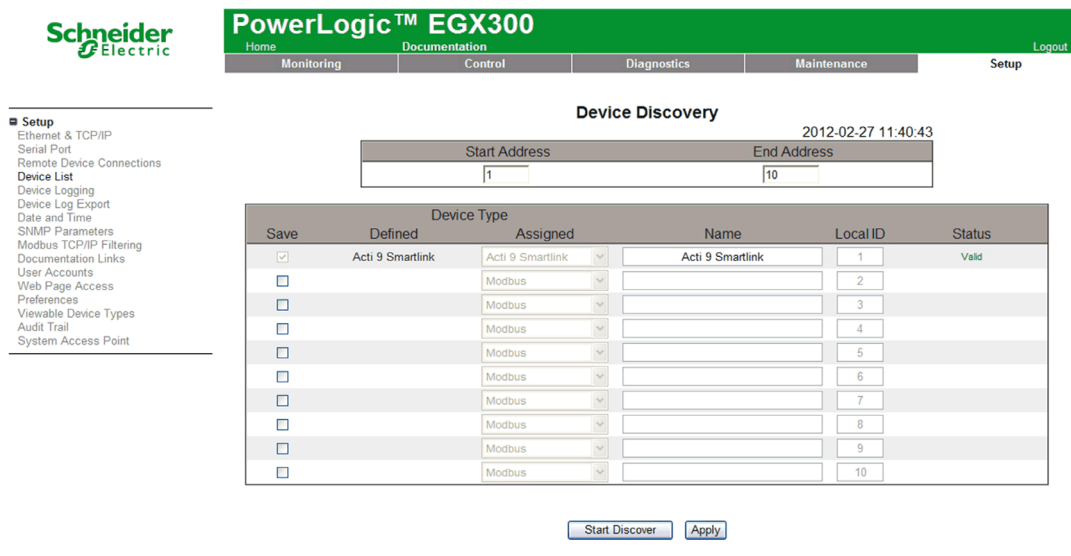

The table describes the automatic detection procedure:

Step	Action
1	Select the Start Address box.
2	Enter the Modbus address where detection is to start.
3	Select the End Address box.
4	Enter the Modbus address up to which detection is to be performed.
5	Click the Start Detection button.
6	If necessary, repeat step 5.

NOTE:

- The automatic detection process can be interrupted at any time by clicking the **Stop Detection** button.
- The device names should be configured manually. Perform steps 1 and 3 of manual configuration.

Manual Configuration

The procedure for manually configuring devices connected to the EGX300 gateway is as follows:

Step	Action
1	Select the Device List page.
2	In the Assigned drop-down menu, select Acti 9 Smartlink .
3	If necessary, in the Name box, type in a name.
4	If necessary, fill in the Local ID field.

Device Logging

The **Device Logging** page is used to configure energy meters connected to the Acti 9 Smartlink device and the file storage and sending parameters.

To go to this page, select the **Configuration** tab, then click on **Device Logging** on the left of the screen.

The following illustration shows the **Device Logging** page:

On this page you need to declare the time interval between 2 recordings. The desired interval is selected from the drop-down list of **Recording Interval** options.

Energy Meter Declarations

From the **Device Logging** page, click on **values**.

The following page will appear:

The procedure for assigning impulse counters to the channels of an Acti 9 Smartlink device is as follows:

Step	Action
1	Check the desired box(es) opposite the Channel x Input y identification.
2	Use the vertical scroll bar to go to the bottom of the page.
3	Click on the Apply button.

NOTE:

For each channel, it is possible to select the type of information required:

- Real energy
- Real power

Declaration of the Device Log Export Type

From the declarations assigning the impulse counter to channels on the Acti 9 Smartlink device, the EGX300 gateway stores each measurement point at the selected frequency and offers the option of exporting the backup files via email or via FTP server.

To define these parameters, in the **Configuration** page, click on **Device Log Export**.

The following page will appear:

The screenshot shows the configuration interface for the PowerLogic™ EGX300. The page title is "Device Log Export". On the left, there is a navigation menu under "Setup" with options like Ethernet & TCP/IP, Serial Port, Remote Device Connections, Device List, Device Logging, Device Log Export (selected), Date and Time, SNMP Parameters, Modbus TCP/IP Filtering, Documentation Links, User Accounts, Web Page Access, Preferences, Viewable Device Types, Audit Trail, and System Access Point. The main content area is divided into three sections: "Transport", "Schedule", and "E-Mail Parameters".

- Transport:** Radio buttons for Disabled, E-Mail (selected), FTP, and HTTP. An "Incremental" checkbox is checked.
- Schedule:** Radio buttons for Logging Interval, Hourly (selected), Daily, Weekly, and Monthly. "Time of Day" is set to 02:00, "Day of the Week" is Sunday, and "Day of the Month" is 1.
- E-Mail Parameters:** "From Address" is david.pellissier@schneider-electric.com. "To Addresses" is also david.pellissier@schneider-electric.com. "Server IP Address" is 0.0.0.0, "Server TCP Port" is 25. There is a checkbox for "SMTP server requires login" which is unchecked. "Username" and "Password" fields are empty.

At the bottom, there are buttons for "Manual Export", "Test E-Mail", "Test FTP", "Test HTTP", and "Apply".

Control

Overview

The **Control** page allows the user to change the Acti 9 Smartlink internal parameters:

- Energy meter pulse weight
- Energy meters

Interface

To access the **Control** page, proceed as follows:

Step	Action
1	Click on the Control tab.
2	Click Acti 9 Smartlink on the left of the screen.
3	The following page displays all the channels and inputs to which an impulse counter is connected.

Schneider Electric **PowerLogic™ EGX300**

Home Documentation **Control** Diagnostics Maintenance Setup Logout

Monitoring

Resets: Acti 9 Smartlink (Acti 9 Smartlink)

Parameter	Preset Value	Pulse Weight	Status
Channel 1 Status Input 1	11414	3	---
Channel 1 Status Input 2	0	10	---
Channel 2 Status Input 1	0	10	---
Channel 2 Status Input 2	0	10	---
Channel 3 Status Input 1	0	10	---
Channel 3 Status Input 2	0	10	---
Channel 4 Status Input 1	0	10	---
Channel 4 Status Input 2	0	10	---
Channel 5 Status Input 1	1616	10	---
Channel 5 Status Input 2	0	10	---
Channel 6 Status Input 1	0	10	---
Channel 6 Status Input 2	0	10	---
Channel 7 Status Input 1	3	10	---
Channel 7 Status Input 2	3	10	---
Channel 8 Status Input 1	0	10	---
Channel 8 Status Input 2	0	10	---
Channel 9 Status Input 1	0	10	---
Channel 9 Status Input 2	0	10	---
Channel 10 Status Input 1	0	10	---
Channel 10 Status Input 2	0	10	---
Channel 11 Status Input 1	1607	10	---
Channel 11 Status Input 2	0	10	---

Reset

Pulse Weight Parameter Setting

If impulse counters have been assigned to the I/O of an Acti 9 Smartlink device, it is possible (or even essential) to configure the counter pulse weight to be able to calculate the real energy and real power.

The table shows how to assign the pulse weight:

Step	Action
1	Check the box opposite the desired channels to change their weight.
2	Check the desired box in the Pulse Weight column.
3	Type in the value of the desired pulse weight.
4	Repeat steps 2 and 3 for each value to be changed.
5	Click the Reset button.

NOTE: If no energy meter has been assigned to a channel of the Acti 9 Smartlink device, we recommend setting the pulse weight to 0.

Resetting Meters

It is possible, if the application requires it, to reset the values of the Acti 9 Smartlink device energy meters.

The table shows how to reset the meters:

Step	Action
1	Check the box opposite the desired channels to change their weight.
2	Check the desired box in the Preset Value column.
3	Type in the new value you wish to assign to the impulse counter concerned.
4	Repeat steps 2 and 3 for each value to be changed.
5	Click the Reset button.

Monitoring

Interface

To display the status of the Acti 9 Smartlink device I/O, go to the **Monitoring** page:

Viewing the I/O

The table describes the procedure for accessing the Acti 9 Smartlink device I/O data:

Step	Action
1	Click on Real Time Data in the left-hand panel.
2	Click on Single Device Pages in the left-hand panel.
3	Click on Acti 9 Smartlink in the left-hand panel.
4	The <i>I/O data (basic readings)</i> screen is displayed.

Parameter	Channel 1	2	3	4	5	6	7	8	9	10	11
Connected Device	Channel 1	Channel 2	Channel 3	Channel 4	Channel 5	Channel 6	Channel 7	Channel 8	Channel 9	Channel 10	Channel 11
Status Input 1	0	0	0	0	0	0	0	0	0	0	0
Status Input 2	0	0	0	0	0	0	0	1	0	0	0
Status Output 1	0	0	0	0	0	0	0	0	0	0	0

Assigning Channel Names

A specific name can be assigned to each channel. The procedure is as follows:

Step	Action
1	On the <i>I/O data (basic readings)</i> screen, click on Channel Names .
2	Click on the channel name to be changed.
3	Type in the new channel name. The number of characters is limited to 10.
4	Repeat steps 2 and 3 for all the channel names to be changed.
5	Click on the Apply button.

The following illustration gives an example of changed channel names:

Channel Names

Channel	Name
1	Channel 1
2	Channel 2
3	Channel 3
4	Channel 4
5	Channel 5
6	Channel 6
7	Channel 7
8	Channel 8
9	Channel 9
10	Channel 10
11	Channel 11

Buttons:

Graphic Representation of Consumption

If impulse counters have been configured, consumption can be displayed in graphic form. The procedure is as follows:

Step	Action
1	In the Monitoring page, click on Device Logging .
2	In the Device drop-down menu, select Acti 9 Smartlink .
3	To select the values to be displayed, press the New Value(s) button.
4	Choose the values to be displayed and press the Apply button.
5	Use the mouse to select an area to be enlarged.

The following illustration gives an example of graphic representation of the meter consumption:

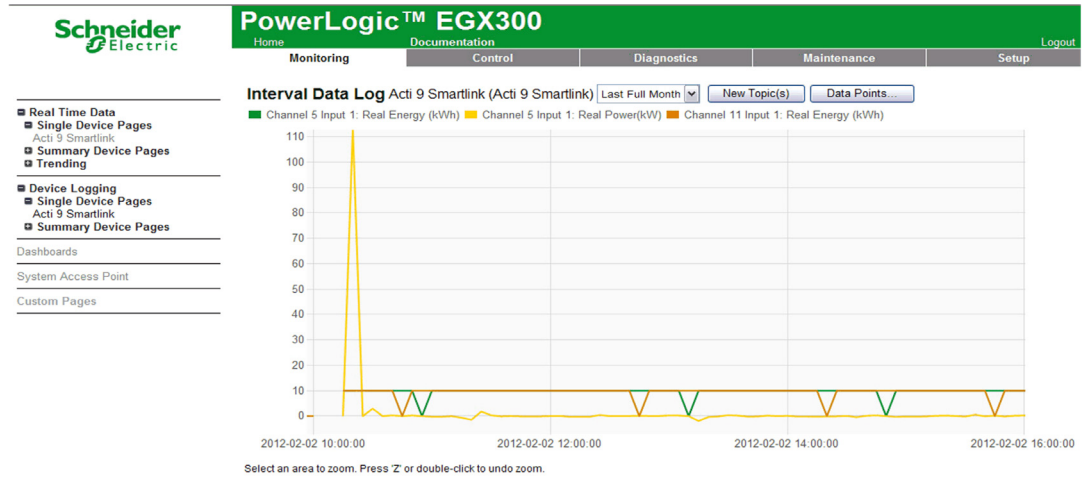

NOTE: By default, only the first channel declared is represented. To display other channels, repeat steps 3 to 5.

Viewing Data

The data is displayed, according to the type of channel and data selected:

- Either discrepancies in total energy between 2 successive recordings
- Or the active power of each recording.

To display these stored values since commissioning, click on the **Access Data** button.

The following page will appear:

Error	Timestamp	Channel 1 Input 1 Real Energy (kWh)	Channel 1 Input 1 Real Power(kW)	Channel 5 Input 1 Real Energy (kWh)	Channel 5 Input 1 Real Power(kW)	Channel 11 Input 1 Real Energy (kWh)	Channel 11 Input 1 Real Power(kW)
0	2012-01-23 09:30:00	10	116.162	10	0	10	0
0	2012-01-23 09:35:00	19	116.718	20	116.480	20	114.821
0	2012-01-23 09:40:00	29	116.792	30	116.116	30	114.354
0	2012-01-23 09:45:00	39	116.016	40	116.336	40	114.573
0	2012-01-23 09:50:00	48	116.830	50	116.436	50	114.693
0	2012-01-23 09:55:00	58	116.279	60	116.369	60	114.887
0	2012-01-23 10:00:00	68	116.050	70	116.614	70	114.887
0	2012-01-23 10:05:00	77	116.979	80	116.426	80	114.878
0	2012-01-23 10:10:00	87	116.391	90	116.488	90	114.708
0	2012-01-23 10:15:00	97	116.364	100	116.647	100	114.876
0	2012-01-23 10:20:00	106	116.391	110	116.741	110	114.971
0	2012-01-23 10:25:00	116	116.391	120	116.818	120	115.052
0	2012-01-23 10:30:00	126	116.580	130	116.953	130	115.181
0	2012-01-23 10:35:00	135	116.487	140	116.953	140	115.122
0	2012-01-23 10:40:00	145	116.504	150	116.893	150	115.115
0	2012-01-23 10:45:00	155	111.111	160	116.889	160	115.115
0	2012-01-23 10:50:00	164	113.888	170	113.236	170	113.029
0	2012-01-23 10:55:00	174	113.672	180	113.196	180	112.993
0	2012-01-23 11:00:00	183	113.600	190	113.050	190	112.335
0	2012-01-23 11:05:00	193	113.314	200	112.952	200	112.208
0	2012-01-23 11:10:00	202	112.528	210	112.796	210	112.055
0	2012-01-23 11:15:00	211	113.636	220	112.804	220	112.093
0	2012-01-23 11:20:00	221	112.852	230	112.888	230	112.166
0	2012-01-23 11:25:00	230	113.171	240	112.306	240	111.579
0	2012-01-23 11:30:00	240	113.207	250	112.507	250	111.776
0	2012-01-23 11:35:00	249	113.171	260	112.651	260	111.902
0	2012-01-23 11:40:00	259	113.350	270	112.485	270	111.752
0	2012-01-23 11:45:00	268	113.493	280	112.395	280	109.683
0	2012-01-23 11:50:00	277	113.421	290	112.902	290	112.156
0	2012-01-23 11:55:00	287	113.584	300	112.973	300	112.233
0	2012-01-23 12:00:00	296	114.649	310	112.973	310	113.122
0	2012-01-23 12:05:00	305	115.722	320	113.895	320	113.346
0	2012-01-23 12:10:00	315	115.015	330	114.111	330	113.794
0	2012-01-23 12:15:00	325	115.199	340	114.405	340	114.021
0	2012-01-23 12:20:00	335	115.468	350	114.536	350	114.147
0	2012-01-23 12:25:00	344	115.589	360	114.784	360	114.259
0	2012-01-23 12:30:00	354	115.495	370	114.902	370	114.334
0	2012-01-23 12:35:00	364	115.199	380	114.765	380	113.952
0	2012-01-23 12:40:00	373	115.310	390	114.726	390	113.934
0	2012-01-23 12:45:00	382	115.458	400	114.719	400	114.688
0	2012-01-23 12:50:00	392	115.606	410	114.752	410	114.003
0	2012-01-23 12:55:00	402	115.644	420	114.876	420	114.688
0	2012-01-23 13:00:00	412	115.347	430	114.946	430	114.224
0	2012-01-23 13:05:00	421	115.126	440	114.722	440	113.896
0	2012-01-23 13:10:00	431	115.089	450	114.532	450	113.783

Diagnostics

Interface

From the EGX300 gateway, diagnostics can be performed on all connected devices. To do this, go to the **Diagnostics** page.

The screenshot shows the Schneider Electric PowerLogic™ EGX300 web interface. The top navigation bar includes Home, Documentation, Diagnostics (selected), Maintenance, and Setup. The left sidebar has a menu with Diagnostics, Statistics, Read Device Registers, and Communications Check. The main content area is titled 'Statistics' and shows the following data:

- Boot Time:** 2012-02-27 08:15:13
- Current Time:** 2012-02-27 12:29:50
- Ethernet:**
 - Link Status: 10BaseTx-HD
 - Frames Transmitted OK: 4849
 - Collisions: 195
 - Excessive Collisions: 0
 - Frames Received OK: 207045
 - CRC Errors: 0
 - Alignment Errors: 0
 - Frames Too Long: 0
 - Frames Too Short: 0
- Serial Port:**
 - Frames Sent: 690
 - Frames Received: 672
 - CRC Errors: 0
 - Protocol Errors: 0
 - Timeouts: 18
 - Exceptions Received: 0
 - Outbound Read Messages: 688
 - Outbound Write Messages: 0
 - Inbound Read Messages: 0
 - Inbound Write Messages: 0
- Gateway Information:**
 - Firmware Version: 4.100
 - System Idle Time: 89%
 - MAC Address: 00:80:67:82:6D:B1
 - Serial Number: 53006800
- Modbus TCP/IP:**
 - Server:**
 - Frames Sent: 0
 - Frames Received: 0
 - Protocol Errors: 0
 - Active Connections: 0
 - Accumulative Connections: 0
 - Maximum Connections: 0
 - Inbound Read Messages: 0
 - Inbound Write Messages: 0
 - Outbound Reply Messages: 0
 - Client:**
 - Frames Sent: 0
 - Frames Received: 0
 - Protocol Errors: 0
 - Timeouts: 0
 - Connection Timeouts: 0
 - Exceptions Received: 0
 - Outbound Read Messages: 0
 - Outbound Write Messages: 0
 - Inbound Reply Messages: 0
- HTTP Server:**
 - Frames Sent: 330
 - Frames Received: 327
 - Active Connections: 4
 - Accumulative Connections: 81
 - Maximum Connections: 5

Reading Registers

On the **Diagnostics** page, click on **Read Device Registers**. The following page will appear:

The screenshot shows the 'Read Device Registers' page in the Schneider Electric PowerLogic™ EGX300 web interface. The page includes a form for selecting a device and reading registers. The 'Device Name' is set to '1'. The 'Starting Register' is '1000' and the 'Number of Registers' is '10'. Below this, a table shows the register values for registers 1000 through 1009, all currently showing '0'. The 'Data Type' is set to 'Holding Registers'.

Register	Value
1000	0
1001	0
1002	0
1003	0
1004	0
1005	0
1006	0
1007	0
1008	0
1009	0

The table describes the procedure for reading registers:

Step	Action
1	In the Device Name drop-down menu, select the desired device.
2	Select the Starting Register field.
3	Enter the address of the first register to be read.
4	Select the Number of Registers field.
5	Enter the number of registers to be read.
6	Click on the Read button.

Appendices



What Is in This Appendix?

The appendix contains the following chapters:

Chapter	Chapter Name	Page
A	Details of Modbus Functions	117
B	Connecting Acti 9 Devices Directly to a PLC	125

Appendix A

Details of Modbus Functions

Overview

This appendix describes Modbus functions supported by the Acti 9 Smartlink device that are not available on the www.modbus.org website. It is not attempting to describe the whole protocol.

What Is in This Chapter?

This chapter contains the following topics:

Topic	Page
Function 8: Modbus Diagnostics	118
Function 43-14: Read Acti 9 Smartlink ID	119
Function 43-15: Read Date and Time	121
Function 43-16: Write Date and Time	122
Function 100-4: Read n Non-Adjacent Words	123

Function 8: Modbus Diagnostics

Structure of Modbus Messages Concerning Acti 9 Smartlink Diagnostic Counter Management

Request

Definition	Number of Bytes	Value
Slave number	1 byte	0x00 to 0x63
Function code	1 byte	0x08
Sub-function code	1 byte	See the table "Sub-function codes" later in this topic
Reserved	2 bytes	0x0000

Sub-function codes

Sub-function Codes (Decimal)	Description
10	Resets all the diagnostic counters
11	Reads the correct bus messages managed by the slave counter
12	Reads the incorrect bus messages managed by the slave counter
13	Reads the exception responses managed by the slave counter
14	Reads the messages sent to the slave counter
15	Reads the broadcast message counter
17	Reads the messages sent to the slave counter sent to the slave but without a response because of exception code 06: slave device busy
18	Reads the incorrect bus messages due to overload errors counter

Response

Definition	Number of Bytes	Value
Slave number	1 byte	0x00 to 0x63
Function code	1 byte	0x08
Sub-function code	1 byte	See the preceding list
Diagnostic counter	2 bytes	Value of diagnostic counter corresponding to the sub-function code

Resetting Counters

The counters are reset to 0:

- When they reach the maximum value 65535.
- When they are reset by a Modbus command (function code 8, sub-function code 10).
- When the power is cut off, or
- When the communication parameters are modified.

Function 43-14: Read Acti 9 Smartlink ID

Structure of Modbus Read Acti 9 Smartlink ID Messages

The ID consists of ASCII characters called objects.

Request for basic information

Definition	Number of Bytes	Value
Slave number	1 byte	0x00...0x63
Function code	1 byte	0x2B
Sub-function code	1 byte	0x0E
Product ID	1 byte	0x01
Object identifier	1 byte	0x00

Response with basic information

Definition	Number of Bytes	Value
Slave number	1 byte	0x00...0x63
Function code	1 byte	0x2B
Sub-function code	1 byte	0x0E
Product ID	1 byte	0x01
Conformity level	1 byte	0x01
Reserved	1 byte	0x00
Reserved	1 byte	0x00
Number of objects	1 byte	0x03
Object 0: manufacturer name	Object number	1 byte 0x00
	Object length	1 byte 0x12
	Object content	18 bytes Schneider Electric
Object 1: product code	Object number	1 byte 0x01
	Object length	1 byte 0x08
	Object content	8 bytes "A9XMSB11"
Object 2: version number	Object number	1 byte 0x02
	Object length	1 byte 0x06 (minimum)
	Object content	6 bytes minimum "Vx.y.z"

Request for complete information

Definition	Number of Bytes	Value
Slave number	1 byte	0x00...0x63
Function code	1 byte	0x2B
Sub-function code	1 byte	0x0E
Product ID	1 byte	0x02
Object identifier	1 byte	0x00

Response with complete information

Definition		Number of Bytes	Value
Slave number		1 byte	0x00...0x63
Function code		1 byte	0x2B
Sub-function code		1 byte	0x0E
Product ID		1 byte	0x02
Conformity level		1 byte	0x02
Reserved		1 byte	0x00
Reserved		1 byte	0x00
Number of objects		1 byte	0x05
Object 0: manufacturer name	Object number	1 byte	0x00
	Object length	1 byte	0x12
	Object content	18 bytes	"Schneider Electric"
Object 1: product code	Object number	1 byte	0x01
	Object length	1 byte	0x08
	Object content	8 bytes	"A9XMSB11"
Object 2: version number	Object number	1 byte	0x02
	Object length	1 byte	0x06 (minimum)
	Object content	6 bytes minimum	"Vx.y.z"
Object 3: manufacturer URL	Object number	1 byte	0x03
	Object length	1 byte	0x1A
	Object content	26 bytes	"www.schneider-electric.com"
Object 4: product name	Object number	1 byte	0x04
	Object length	1 byte	0x12
	Object content	18 byte	"Acti 9 Smartlink"

NOTE: The preceding table describes how to read the ID of a Modbus Acti 9 Smartlink slave.

Function 43–15: Read Date and Time

Structure of Modbus Read Date and Time Messages

Request

Definition	Number of Bytes	Value	Example
Slave number	1 byte	0x2F	47
Function code	1 byte	0x2B	43
Sub-function code	1 byte	0x0F	15
Reserved	1 byte	0x00	Reserved

Response

Definition			Number of Bytes	Value	Example
Slave number			1 byte	0x2F	47
Function code			1 byte	0x2B	43
Sub-function code			1 byte	0x0F	15
Reserved			1 byte	0x00	Reserved
Date and time ⁽¹⁾	byte 1	Not used	1 byte	0x00	Not used
	byte 2	Year	1 byte	0x0A	Year 2010
	byte 3	Month	1 byte	0x0B	Month of November
	byte 4	Day of the month	1 byte	0x02	Second day of the month
	byte 5	Hour	1 byte	0x0E	14 hours
	byte 6	Minute	1 byte	0x20	32 minutes
	byte 7 and byte 8	Millisecond	2 bytes	0x0DAC	3.5 seconds

(1) See description of the DATE type ([see page 74](#)).

Function 43-16: Write Date and Time

Structure of Modbus Write Date and Time Messages

Request

Definition		Number of Bytes	Value	Example	
Slave number		1 byte	0x2F	47	
Function code		1 byte	0x2B	43	
Sub-function code		1 byte	0x10	16	
Reserved		1 byte	0x00	Reserved	
Date and time ⁽¹⁾	byte 1	not used	1 byte	0x00	Not used
	byte 2	Year	1 byte	0x0A	Year 2010
	byte 3	Month	1 byte	0x0B	Month of November
	byte 4	Day of the month	1 byte	0x02	Second day of the month
	byte 5	Hour	1 byte	0x0E	14 hours
	byte 6	Minute	1 byte	0x20	32 minutes
	byte 7 and byte 8	Millisecond	2 bytes	0x0DAC	3.5 seconds
(1) See description of the DATE type (see page 74).					

Response

Definition		Number of Bytes	Value	Example	
Slave number		1 byte	0x2F	47	
Function code		1 byte	0x2B	43	
Sub-function code		1 byte	0x10	15	
Reserved		1 byte	0x00	Reserved	
Date and time ⁽¹⁾	byte 1	Not used	1 byte	0x00	Not used
	byte 2	Year	1 byte	0x0A	Year 2010
	byte 3	Month	1 byte	0x0B	Month of November
	byte 4	Day of the month	1 byte	0x02	Second day of the month
	byte 5	Hour	1 byte	0x0E	14 hours
	byte 6	Minute	1 byte	0x20	32 minutes
	byte 7 and byte 8	Millisecond	2 bytes	0x0DAE	3.502 seconds
(1) See description of the DATE type (see page 74).					

Function 100–4: Read n Non-Adjacent Words

Structure of Modbus Read n Non-Adjacent Words Messages Where $n \leq 100$

Request

Definition	Number of Bytes	Value
Modbus slave number	1 byte	0x2F
Function code	1 byte	0x64
Length of data in bytes	1 byte	0x06
Sub-function code	1 byte	0x04
Transmission number ⁽¹⁾	1 byte	0xXX
Address of the first word to be read (MSB)	1 byte	0x00
Address of the first word to be read (LSB)	1 byte	0x65
Address of the second word to be read (MSB)	1 byte	0x00
Address of the second word to be read (LSB)	1 byte	0x67
(1) The master gives the transmission number in the request.		

NOTE: The preceding table describes how to read addresses 101 = 0x65 and 103 = 0x67 of a Modbus slave. The Modbus slave number is 47 = 0x2F.

Response

Definition	Number of Bytes	Value
Modbus slave number	1 byte	0x2F
Function code	1 byte	0x64
Length of data in bytes	1 byte	0x06
Sub-function code	1 byte	0x04
Transmission number ⁽¹⁾	1 byte	0xXX
First word read (MSB)	1 byte	0x12
First word read (LSB)	1 byte	0x0A
Second word read (MSB)	1 byte	0x74
Second word read (LSB)	1 byte	0x0C
(1) The slave sends back the same number in the response.		

NOTE: The preceding table describes how to read addresses 101 = 0x65 and 103 = 0x67 of a Modbus slave. The Modbus slave number is 47 = 0x2F.

Appendix B

Connecting Acti 9 Devices Directly to a PLC

What Is in This Chapter?

This chapter contains the following topics:

Topic	Page
iACT24 Auxiliary for iCT Contactor	126
iATL24 Auxiliary for iTL Impulse Relay	127
iOF+SD24 Indication Auxiliary	128
OF+SD24 Indication Auxiliary	129
Acti 9 RCA iC60 Remote Control with Ti24 Interface	130
Acti 9 Reflex iC60 Integrated Control Circuit Breaker With Ti24 Interface	131

iACT24 Auxiliary for iCT Contactor

Description

The iACT24 auxiliary:

- Can be used to control an iCT contactor rated 25 A or higher via its Y1, Y2 and Y3 inputs.
The Y3 (24 Vdc) input can be directly controlled by a PLC (Programmable Logic Controller).
- Is used to find out the contactor status (O/C status: open/closed status)

An iACT24 auxiliary for iCT contactor can also be connected with an A9XCAU06 or A9XCAC01 pre-wired cable: molded connector (at iACT24 end), and with 5 wires (at PLC end).

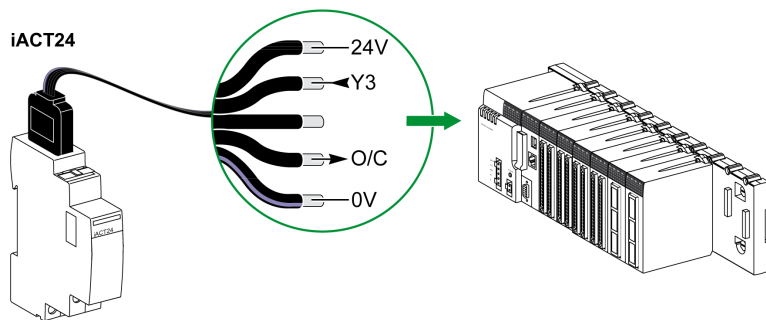

Description of Ti24 Connector at iACT24 End (Using an A9XCAU06 or A9XCAC01 Cable)	
Terminal	Description
24 V	24 V of the 24 Vdc power supply
Y3	Control input
Unused terminal	–
O/C	Open/closed contactor state
0 V	0 V of the 24 Vdc power supply

NOTE:

- Do not connect 2 wires in each of the Ti24 connector terminals (A9XC2412).
- Do not connect a wire with cable end in each of the Ti24 connector terminals.

iATL24 Auxiliary for iTL Impulse Relay

Description

The iATL24 auxiliary:

- Can be used to control an iTL impulse relay via its Y1, Y2 and Y3 inputs
The Y3 (24 Vdc) input can be directly controlled by a PLC.
- Is used to find out the impulse relay status (O/C status: open/closed status)

An iATL24 auxiliary for iTL impulse relay can also be connected with an A9XCAU06 or A9XCAC01 pre-wired cable: molded connector (at iATL24 end), and with 5 wires (at PLC end).

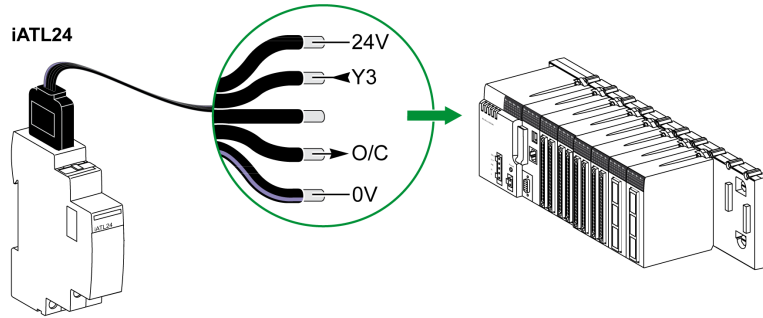

Description of Ti24 Connector at iATL24 End (Using an A9XCAU06 or A9XCAC01 Cable)	
Terminal	Description
24 V	24 V of the 24 Vdc power supply
Y3	Control input
Unused terminal	–
O/C	Open/closed impulse relay status
0 V	0 V of the 24 Vdc power supply

NOTE:

- Do not connect 2 wires in each of the Ti24 connector terminals (A9XC2412).
- Do not connect a wire with cable end in each of the Ti24 connector terminals.

iOF+SD24 Indication Auxiliary

Description

The iOF+SD24 indication auxiliary is used to find out the status of the following devices:

- iC60 and iC65 circuit breaker (OF and \overline{SD} states)
- iID residual current circuit breaker (OF and \overline{SD} states)
- iSW-NA switch (OF status)
- iDPN circuit breaker (sold in China)

The iOF+SD24 indication auxiliary for iC60 circuit breaker can also be connected with an A9XCAU06 or A9XCAC01 pre-wired cable: molded connector (at iOF+SD24 end), and with 5 wires (at PLC end).

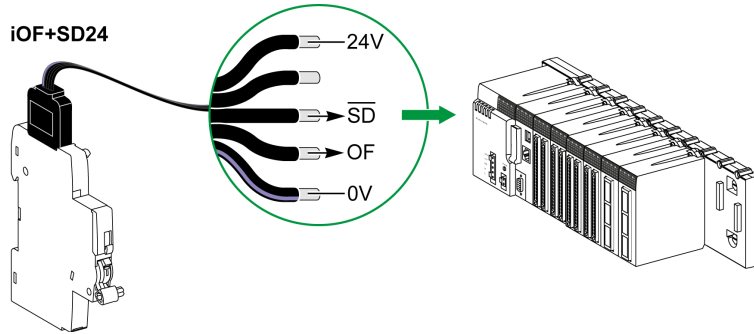

Description of Ti24 Connector at iOF+SD24 End (Using an A9XCAU06 or A9XCAC01 Cable)	
Terminal	Description
24 V	24 V of the 24 Vdc power supply
Unused terminal	–
\overline{SD}	Fault indication
OF	Open/closed circuit breaker status
0 V	0 V of the 24 Vdc power supply

NOTE:

- Do not connect 2 wires in each of the Ti24 connector terminals (A9XC2412).
- Do not connect a wire with cable end in each of the Ti24 connector terminals.

OF+SD24 Indication Auxiliary

Description

The OF+SD24 indication auxiliary is used to find out the status of the following devices:

- C60 or C120 circuit breaker (OF and \overline{SD} states)
- DPN residual current circuit breaker (OF and \overline{SD} states)
- DPN switch (OF status)
- C60H-DC circuit breaker (OF and \overline{SD} states)
- iDPN circuit breaker (sold in every country except China)

The OF+SD24 indication auxiliary for C60 and C120 circuit breakers can also be connected with an A9XCAU06 or A9XCAC01 pre-wired cable: molded connector (at OF+SD24 end), and with 5 wires (at PLC end).

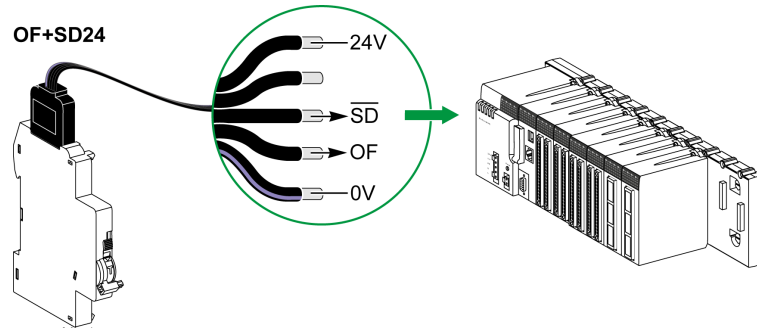

Description of Ti24 Connector at OF+SD24 End (Using an A9XCAU06 or A9XCAC01 Cable)	
Terminal	Description
24 V	24 V of the 24 Vdc power supply
Unused terminal	–
\overline{SD}	Fault indication
OF	Open/closed circuit breaker status
0 V	0 V of the 24 Vdc power supply

NOTE:

- Do not connect 2 wires in each of the Ti24 connector terminals (A9XC2412).
- Do not connect a wire with cable end in each of the Ti24 connector terminals.

Acti 9 RCA iC60 Remote Control with Ti24 Interface

Description

The Acti 9 RCA iC60 remote control:

- Should have a Ti24 interface (product references A9C70122 and A9C70124)
- Can be used to control a iC60 circuit breaker via input Y3 of its Ti24 interface. The Y3 (24 Vdc) input can be directly controlled by a PLC.
- Can be used to find out the OF and \overline{SD} states of the circuit breaker associated with the Acti 9 RCA iC60 remote control

An RCA iC60 remote control with Ti24 interface can also be connected with an A9XCAU06 or A9XCAC01 pre-wired cable: molded connector (at RCA iC60 end with Ti24 interface), and with 5 wires (at PLC end).

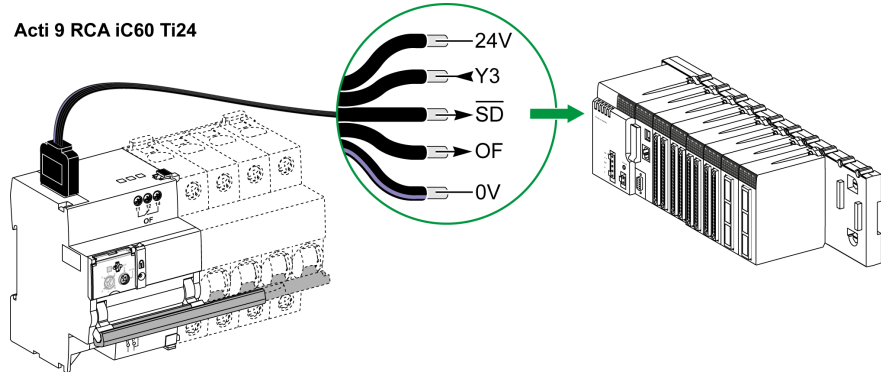

Description of Ti24 Connector at Acti 9 RCA iC60 End with Ti24 Interface (Using an A9XCAU06 Cor A9XCAC01 Cable)	
Terminal	Description
24 V	24 V of the 24 Vdc power supply
Y3	Control input
\overline{SD}	Fault indication
OF	Open/closed status of the RCA iC60 with Ti24 interface
0 V	0 V of the 24 Vdc power supply

NOTE:

- Do not connect 2 wires in each of the Ti24 connector terminals (A9XC2412).
- Do not connect a wire with cable end in each of the Ti24 connector terminals.

Acti 9 Reflex iC60 Integrated Control Circuit Breaker With Ti24 Interface

Description

The Acti 9 Reflex iC60 integrated control circuit breaker:

- Should have a Ti24 interface (with product references A9C6****)
- Can allow the device to be controlled via input Y3 of its Ti24 interface.
The Y3 (24 Vdc) input can be directly controlled by a PLC.
- Can be used to communicate its O/C and auto/OFF status

An Acti 9 Reflex iC60 integrated control circuit breaker with Ti24 interface can also be connected with an A9XCAU06 or A9XCAC01 pre-wired cable: molded connector (at Reflex iC60 end with Ti24 interface), and with 5 wires (at PLC end).

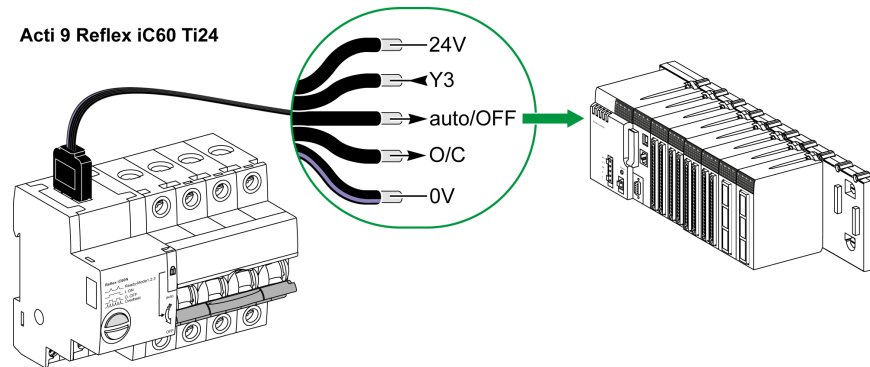

Description of Ti24 Connector at Acti 9 Reflex iC60 End With Ti24 Interface (Using an A9XCAU06 or A9XCAC01 Cable)	
Terminal	Description
24 V	24 V of the 24 Vdc power supply
Y3	Control input
auto/OFF	Handle position (upper position: auto; lower position: OFF)
O/C	Open/closed status of the Reflex iC60 with Ti24 interface
0 V	0 V of the 24 Vdc power supply

NOTE:

- Do not connect 2 wires in each of the Ti24 connector terminals (A9XC2412).
- Do not connect a wire with cable end in each of the Ti24 connector terminals.



DOCA0004EN-06

Schneider Electric Industries SAS

35, rue Joseph Monier
CS30323
F - 92506 Rueil Malmaison Cedex

www.schneider-electric.com

As standards, specifications and designs change from time to time, please ask for confirmation of the information given in this publication.

04/2016