

THORGEON
SENSORS

PRESENCE SENSOR

02024



Manufactured in PRC

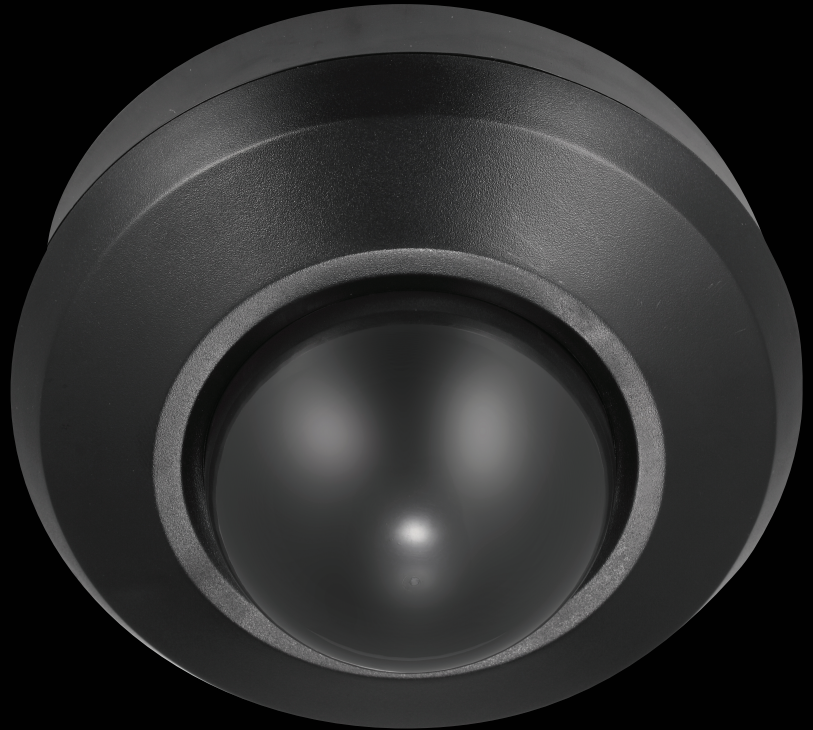

BUILT-IN



1000W



360°



<20m



220-240V



2000W



50-60



IP44



THORGEON



www.thorgeon.com
SIA "ATTA-1", Daugavgrivas street 77,
Riga, Latvia, LV-1007



4751029898579

Developed in Latvia

Welcome to the infrared presence sensor!

Congratulations on purchasing our new sensor. You have chosen a high-quality product that has been manufactured, tested and packed with the greatest care. Please familiarize yourself with these instructions before attempting to install the product. The prolonged, reliable and trouble-free operation will only be ensured if it is fitted and used properly. We hope your new sensor will bring you lasting pleasure.

SPECIFICATION:

Power Source:	220-240V/AC	Detection Range:	360°
Power Frequency:	50/60Hz	Detection Distance:	20m max(<24°C)
Ambient Light (adjustable):	<3-2000LUX	Working Temperature:	-20~+40°C
Time Delay:	Min. 10sec±3sec Max. 30min±2min	Working Humidity:	<93% RH
Max Rated Load:	2000W  1000W 	Power Consumption:	0.5W
		Installation Height:	2.2-6m

FUNCTION:

- Sensor can identify day and night: the consumer can adjust working state in different ambient light. It can work in the daytime and at night when it is adjusted on the “sun” position (max). It can work in ambient light less than 3LUX, when it is adjusted on the “3” position (min). As for the adjustment pattern, please refer to the testing pattern.
- Time-Delay is added continually: When sensor receives the second induction signals within the first induction, it will restart to time from the moment.

MANUAL OVERRIDE FUNCTION:

1. Sensor mode → Stays ON

Use sensor OFF-ON switch twice within 3 sec. - the sensor will now hold your light ON continuously just like a normal light.

2. Stays ON → Sensor mode (either of following methods can be used)

- 1) Turn switch position to OFF, then switch ON after 0.3 sec.
- 2) If the light is left ON (not changed in switch positions by hand), the sensor will also automatically return to the sensor mode after 8 hours.

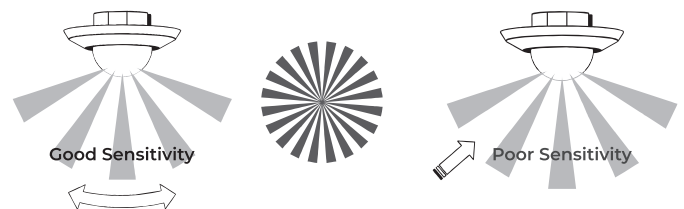

INSTALLATION ADVICE:

As the detector responds to changes in temperature, avoid the following situations:

- Avoid pointing the detector towards objects with highly reflective surfaces, such as mirrors etc.
- Avoid mounting the detector near heat sources, such as heating vents, air conditioning units, light etc.
- Avoid pointing the detector towards objects that may move in the wind, such as curtains, tall plants etc.

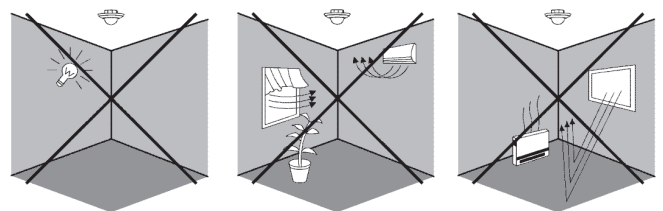

Warning. Danger of death through electric shock!



- Must be installed by a professional electrician.
- Disconnect from power source.
- Cover or shield any adjacent “live” components.
- Ensure device cannot be switched ON.

INSTALLATION (3 METHODS):

Method 1: Recessed mounting

- Unload the vinyl cover at the bottom of the sensor.
- Loose the screws in the connection terminal, and then connect the power to connection terminal of sensor according to connection-wire diagram.
- Install back the vinyl cover into the original location.
- Fold the metal spring of the sensor upwards, until they are in "I" position with sensor, and then put the sensor into the hole or installation box which is on the ceiling and has the similar size with the sensor. Releasing the spring, the sensor will be set in this installation position.
- After finishing installing, turn on the power and then test it.

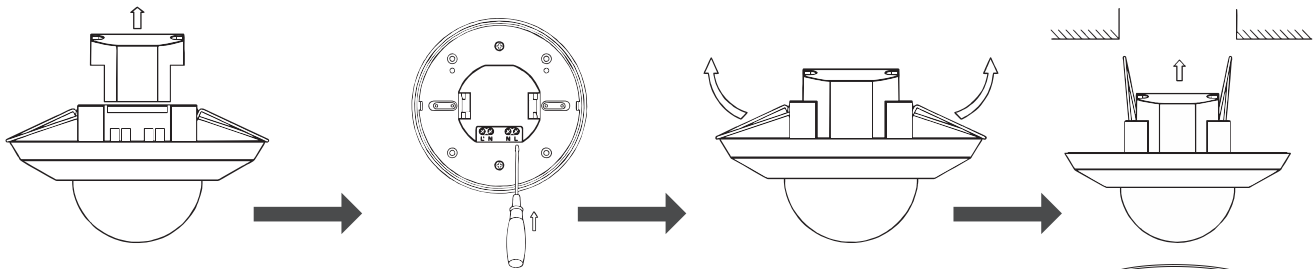

Method 2: Surface mounting

- Remove the metal spring from the sensor and use the bottom casing.
- Move the upper cover anti-clockwise whirl as per the diagram.
- Connect the power and the load according to the connection-wire diagram.
- Fix the bottom casing on the selected position with the inflated screw.
- Install the upper cover back on the sensor, then you can switch on the power and test it.

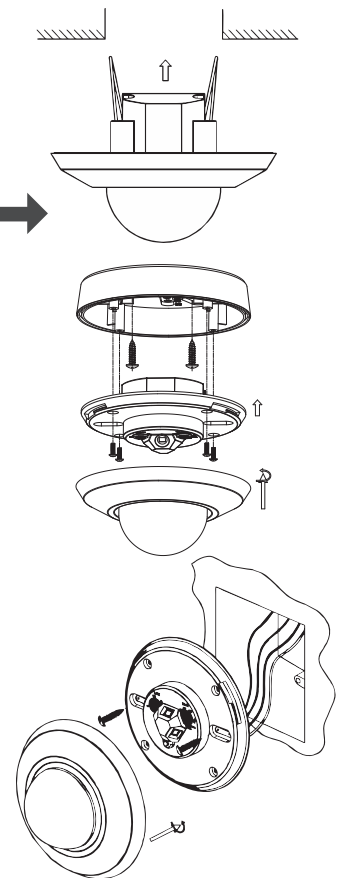

Method 3: Mounting in junction box.

- Remove the metal spring and bottom casing of the sensor.
- Loose the screws in the connection terminal, and then connect the power to connection terminal of sensor according to connection-wire diagram.
- Install the sensor into the junction box, fix the screw through the mounting hole.
- Install the faceplate, switch on the power and test the sensor.

SENSOR INFORMATION:

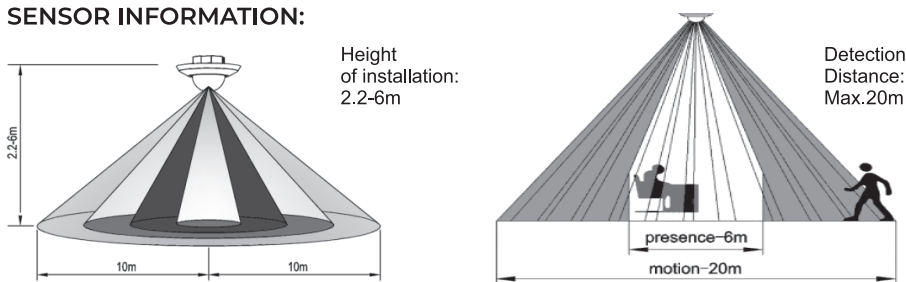

- Turn the TIME knob anti-clockwise to the minimum (10s). Turn the LUX knob clockwise to the maximum (sun).
- Switch on the power; the sensor and its connected lamp will have no signal at the beginning. After warm-up (30 sec), the sensor can start working. If the sensor receives the induction signal, the lamp will turn on. While there is not another induction signal any more, the load should stop working within 10 sec±3 sec and the lamp would turn off.
- Turn LUX knob anti-clockwise on the minimum (3). If the ambient light is more than 3 LUX, the sensor would not work, and the lamp would stop working too. If the ambient light is less than 3 LUX (darkness), the sensor would work. Under no induction signal condition, the sensor should stop working within 10 sec±3sec.

CONNECTION-WIRE DIAGRAM:

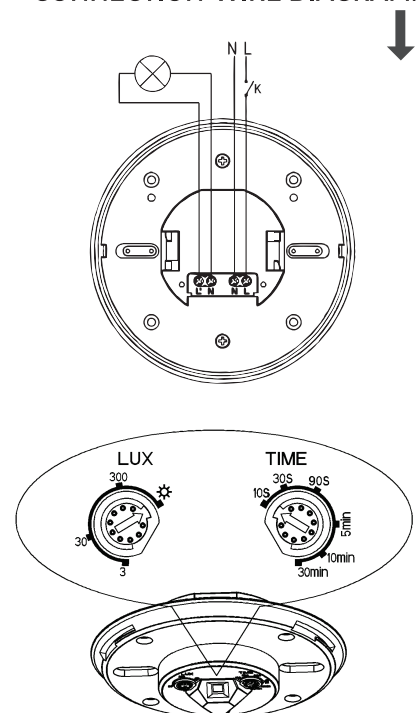

Note: when testing in daylight, please turn LUX knob to ☀ (SUN) position, otherwise the sensor lamp will not work! If the lamp is more than 60W, the distance between lamp and sensor should be at least 60cm.

SOME PROBLEM AND SOLVED WAY:

The load does not work:

- a. Check if the connection-wiring of power and load is correct.
- b. Check if the load is good.
- c. Check if the working light sets correspondingly to ambient light.

The sensitivity is poor:

- a. Check if there is any hindrance in front of the detection window to affect the received signal.
- b. Check if the ambient temperature is too high.
- c. Check if the induction signal source is in the detection fields.
- d. Check if the installation height corresponds to the height shown in the instruction.
- e. Check if the moving orientation is correct.

The sensor cannot shut off the load automatically:

- a. Check if there is continual signal in the detection field.
- b. Check if the time delay is the longest.
- c. Check if the power corresponds to the instruction.

