

Product Data Sheet

GW10496M

CHORUSMART - Domestic range

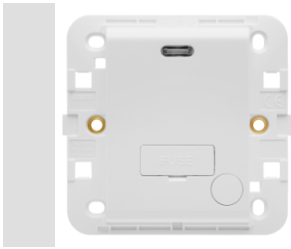

Wiring devices system characterized by its profile and shape inspired to the Chorus family feeling. Wide range of plates with an Italian design, articulated into two families, GEO and LUX cover plates, available in many materials and finishes. The range is available in three colors: glossy white, satin black, painted titanium and fits in 3x3 inches (1-gang) and 3x6 inches (2-gang) British Standard boxes. Range expandable thanks to the Chorus modular devices.

Category	Unswitched fused connection unit	Description	13 A
Colour	White	Type	Backlit
Voltage	250V ac	Wiring terminals	With screw
Standard	BS 1363-4	Resistance at test voltage	2000 V at 50 Hz for 1 minute
Insulation resistance	> 5 MOhm	Thermo-pressure with ball	125 °C
Glow Wire Test	850 °C	Terminal grip on cable traction	> 50 N
Terminal tightening capacity stranded cables (mm ²)	min. 1 - max. 2,5	Terminal tightening capacity solid cables (mm ²)	min. 1 - max. 2,5
Cable Ø min	5 mm	Cable Ø max	11 mm

DIMENSIONAL

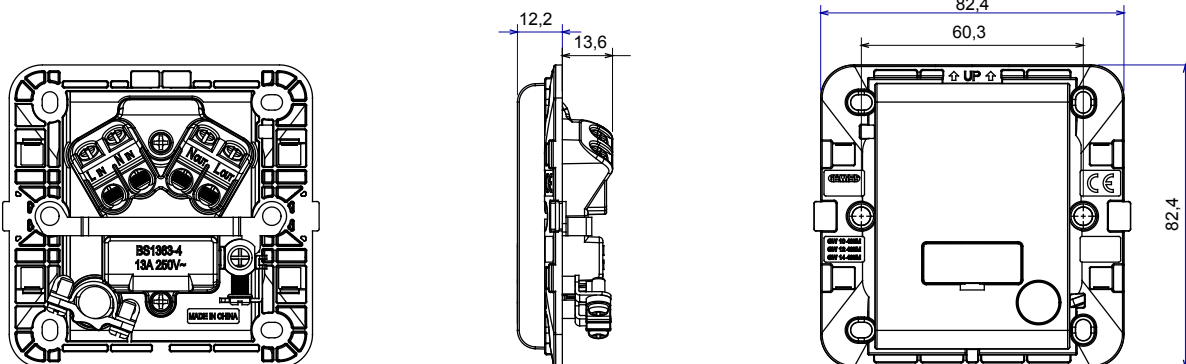

TECHNICAL SYMBOLOGY



STANDARDS/APPROVALS

