

Product Data Sheet

GWS6911

ESALITE HB

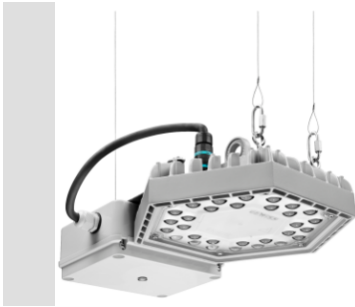

Industrial LED lighting fixture made of die-cast EN AB 46100 aluminum with polyester powder coating. Correct lighting is provided by an optical system composed of different versions of lenses. Silicone gaskets, breathing and anti-condensation device in Goretex, waterproof connectors for 1.5 mm² cables and stainless steel external screws. Suspension fixing system with steel cables. The die-cast aluminum structure guarantees optimal performance conditions both @ Ta25 ° and @ Ta50 ° thanks to specific thermal sizing tests. The correct heat dispersion inside ESALITE is guaranteed by the special passive heat sink with a very low copper content that offers high qualitative and quantitative performances. Permanent emergency version with 3h autonomy and high temperature NiMH batteries. Signalling LED for charge status.

GENERAL INFORMATION		OPTIC AND ILLUMINATING FEATURES	
Context	Logistics and industrial manufacturing lighting	Optic	Wide 90°
Luminaire	LED Industrial Reflector	Unified Glare Rating	UGR ≤ 25
Application	Internal	Lumen output (lm)	6700 (650 em.)
Unique digital code (Datamatrix)	Datamatrix	Efficacy (lm/W)	129
Colour	Grey RAL 9006	Colour temperature	4000 K
Type of light source	LED	Colour Rendering Index	CRI>80
System power	52W (+5W Emerg.)	Standard Deviation Colour Matching	SDCM = 3
LED Lifetime	L90B10 (Tq 25°) 100000 h; L90B10 (Tq 50°) 55000 h	Photobiological Risk Class	RG0
Weight (kg)	4.5	Standard	EN60598-1; EN60598-2-22; IEC 62778; IEC62471
Warranty	5 years	ELECTRICAL AND LIGHTING FEATURES	
Stocking temperature	0°C ÷ +50°C / HR 10% ÷ 85%	Supply voltage	220-240 V
Operating temperature	0°C ÷ +40 °C	Rated frequency (Hz)	50 / 60
MATERIALS		Driver	-
Body	Die-cast aluminium	Driver failure rate	-
Shield type	High transparency PMMA	Overvoltage protection	DM 6KV / CM 8KV
Optic	PMMA lens	Control System	DALI
Gasket	Silicon	INSTALLATION AND MAINTENANCE	
Locking Hook	-	Mounting and installation	Suspended
External screw	Stainless steel	Tilt	Not possible
Colour	Polyester powder coated	Wiring	With watertight connector
STANDARDS AND APPROVALS		Fixing	-
Classification	Emergency 3h	Light source replaceability	Non-replaceable
Device with reduced surface temperature	-	Controlgear replaceability	By professional
DIN 18032-3 certification	No	Driver Box	Built-in
IPEA	-	Maximum surface exposed to the wind	0,06 m ²
Insulation class	I		
IP degree	IP55		
Mechanical resistance	IK06		
Glow Wire Test	650 °C		

DIMENSIONAL

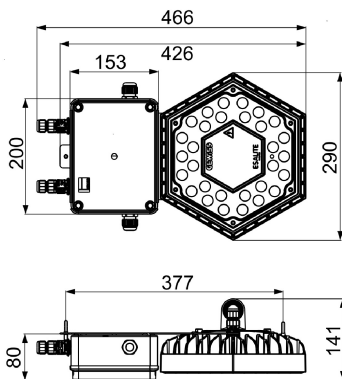

PHOTOMETRIC DISTRIBUTION

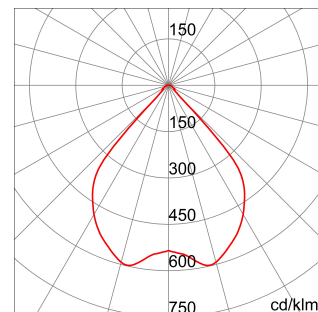

TECHNICAL SYMBOLOGY



IP
IP55

IK
IK06

GWT
650 °C

Product Data Sheet

GWS6911

ESALITE HB

STANDARDS/APPROVALS

