

Autonomous Mobile Robots

LD Series

Designed to automate material transport tasks in factories and indoor facilities.

- Natural-feature navigation:
Automatically plans efficient routes and prevents collisions
- Fleet management:
Supervises and coordinates the entire fleet of up to 100 vehicles
- Easy deployment:
Short installation time, no facility modifications



Ordering Information

Product Name	Maximum Load	Docking Station Kit *1	Top Plate	Pendant (Joystick)	Part Number
LD-60	60 kg		No		37032-00000
		Yes		No	37032-00002
			Yes		37032-10004
LD-60 ESD *2			No		37032-20000
		Yes		No	37032-20002
			Yes		37032-20004
LD-90	90 kg		No		37042-00000
		Yes		No	37042-00002
			Yes		37042-10004
LD-90x *3			No		37062-00000
		Yes		No	37062-00002
			Yes		37062-10004
LD-90 ESD *2			No		37042-20000
		Yes		No	37042-20002
			Yes		37042-20004
LD-90x ESD *2 *3			No		37062-20000
		Yes		No	37062-20002
			Yes		37062-20004
LD-250	250 kg		No		37222-00000
		Yes		No	37222-00002
			Yes		37222-10004
LD-250 ESD *2			No		37222-20000
		Yes		No	37222-20002
			Yes		37222-20004

*1. Includes Battery Power Cable.

*2. For use in electrostatic-sensitive environments, compliant to the IEC 61340-5-1 standard.

*3. For use in cart transporter applications.

Note: 1. To ensure proper fleet management, please contact an OMRON representative before ordering AMRs to add to an existing fleet.











2. The battery for the AMR must be ordered separately (part number 20452-000). Before ordering lithium-ion batteries, please verify local shipping regulations to ensure compliance with applicable laws and restrictions.





LD Series

Items Included With the AMR

Item	Description
HMI Jumper	HDB15 male plug
Wireless Antennas	Two rubber duck antennas with SMA plugs
Labels	Warning and product labels
USB drive	Contains digital product documentation and software for operating the AMR
Printed Documentation	Printed manuals and guides for unpacking and operating the AMR

Accessories and Optional Items

Appearance	Item	Details	Part Number
	EM2100 Appliance	Appliance that runs any Fleet Operations Workspace Solutions software. 120 day factory trial license included. Refer to Fleet Operations Workspace (FLOW) Licenses below for more information.	20271-900 (Primary Fleet Manager) 20271-901 (Secondary Fleet Manager) 20271-903 (Bundle with Fleet Simulator License)
	Mobile I/O Box	Used with a Fleet Manager to summon an AMR to a goal or control connected devices with I/O	23419-802
	Mobile I/O Box Power Supply	Recommended for purchase with the Mobile I/O Box	23419-812
	High Accuracy Positioning System (HAPS) Single sensor	AMR Alignment using magnetic floor tape. Includes single HAPS sensor kit, one mounting bracket, cabling, hardware, and magnetic tape (254 mm wide, 49 m long)	LD-60/90: 13660-100 LD-250: 21374-100
	High Accuracy Positioning System (HAPS) Double sensor	AMR Alignment using magnetic floor tape. Includes double HAPS sensor kit, two mounting brackets, cabling, hardware, and magnetic tape (254 mm wide, 49 m long)	LD-60/90: 13660-000 LD-250: 21374-000
	Magnetic tape	25 mm wide magnetic tape (South top side, 49 m roll)	14925-000
	Acuity Localization	Camera, mounting kit, cables, leveling kit	13700-000
		Camera, mounting kit, cables, no leveling kit	13700-100
	Side Laser Bundle	Includes two Lasers, mounting kit, and cable	13456-000
	Side Laser Kit	Includes two lasers, two mounting kits, two metal covers, and cable	13456-100
	Battery *	Removable and rechargeable power source for the AMR.	20452-000
	Docking Station	Used to autonomously charge the battery inside an AMR or to charge an AMR battery outside of the AMR with a battery power cable (sold separately)	12477-000
	Battery Power Cable	Cable length: 0.45 m	12676-000L
	Pendant (Joystick)	Handheld device for manually driving an AMR and map creation, 3 m cable length	13558-000

Appearance	Item	Details	Part Number
	Digital I/O Terminal Block Kit	Provides a terminal block for the Digital I/O connector on the Core. Includes a 0.76 m male to female cable, terminal block, and a mounting bracket	14165-000
	Top Plate - LD-60, LD-90, LD-90x	Provides additional protection for the AMR.	12944-000
	Top Plate - LD-250	Provides additional protection for the AMR.	20458-002
	Top Plate - LD-250 ESD		20458-202
	Rear Facing Laser Bundle	Provides CAPS functionality while the AMR is traveling in the reverse direction. Includes TiM laser and required cables.	21446-000

* Before ordering lithium-ion batteries, please verify local shipping regulations to ensure compliance with applicable laws and restrictions.

Software Licenses

Product Name	Applicable For	Configuration	Part Number
Fleet Operations Workspace (FLOW) Core Fleet Manager License, 3 Year	Virtual Fleet Manager	Initial entitlement for a 3 year renewable FLOW Core license. Replace □□ with 05, 10, 15, 20, 25, 30, 50 to indicate the number of AMRs licensed to connect, where 50 represents an unlimited number of AMRs.	30271-1□□ *1
Fleet Operations Workspace (FLOW) Core Fleet Upgrade		Entitlement for fleet connection limit increase by one additional AMR (used for existing installations).	30271-001
Fleet Operations Workspace (FLOW) Core Renewal		Entitlement for a 1 year (verify) renewal of the FLOW Core license. Replace □□ with a value of 05 to 30, or 50 to indicate the number of AMRs licensed to connect, where 50 represents an unlimited number of AMRs.	30271-2□□
Fleet Operations Workspace (FLOW) iQ License		Entitlement for a 1 year renewable FLOW iQ license. Entitlement for a 3 year renewable FLOW iQ license.	30271-701 30271-703
Primary Fleet Operations Workspace (FLOW) Core License, 1 Year	EM2100	Entitlement for a 1 year renewable Primary FLOW Core license, runtime and development, per AMR connection	20271-800 *2
Primary Fleet Operations Workspace (FLOW) Core License, 5 Year		Entitlement for a 5 year renewable Primary FLOW Core license, runtime and development, per AMR connection	20271-806 *2
Secondary Fleet Operations Workspace (FLOW) Core License, 1 Year		Entitlement for a 1 year renewable Secondary FLOW Core license per fleet, redundant runtime	20271-802 *2
Secondary Fleet Operations Workspace (FLOW) Core License, 5 Year		Entitlement for a 5 year renewable Secondary FLOW Core license per fleet, redundant runtime	20271-807 *2
License, Fleet Operations Workspace iQ		Entitlement for a 1 year renewable FLOW iQ license Entitlement for a 5 year renewable FLOW iQ license	20271-701 20271-705
Cell Alignment Positioning System (CAPS) License		AMR	AMR Alignment using software-defined target. Entitlement for a perpetual CAPS license

*1. After expiration of a FLOW Core Fleet Manager license, all Virtual Fleet Manager functionality will continue to operate without requiring subscription renewals. An active subscription will still be required to access subsequent software releases, including bug fixes, feature upgrades, and performance improvements.

*2. Expiration of a 1 year subscription license without renewal will result in cessation of the EM2100 fleet management functions of the OMRON AMR solution until the license is renewed. This does not apply to Virtual Fleet Manager.
After five consecutively licensed years (either one 5 year license or five 1 year licenses), all EM2100 fleet management functions will continue to operate without requiring subsequent subscription renewals. An active subscription will still be required to access new software releases, including bug fixes, feature upgrades, and performance improvements.

Note: To upgrade to the latest version of the FLOW Core software, contact your local OMRON representative. Please note that an active subscription is required for access to software upgrades.

LD Series

Features and Components

LD-60, LD-90, LD-90x, LD-60 ESD, LD-90 ESD, and LD-90x ESD

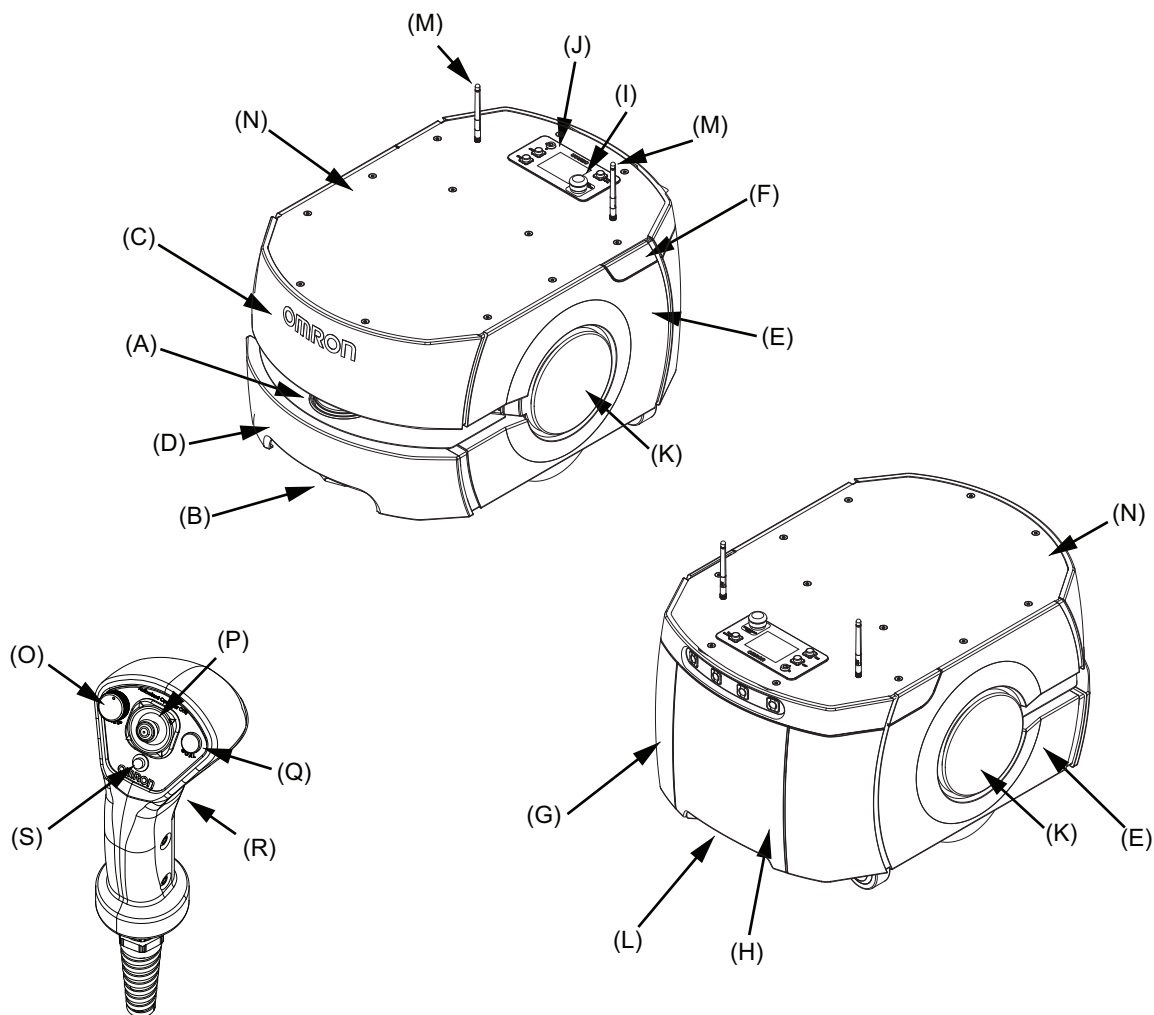

Item	Description	Item	Description
A	Safety Laser Scanner	K	Light Disk
B	Low Laser	L	Charging Contacts
C	Upper Front Skin	M	Wireless Antennas
D	Bumper Skin	N	Payload Mounting Surface (Top Plate shown)
E	Side Skin	O	Speed Control
F	Access Panel	P	Directional Control Stick
G	Rear Skin	Q	Goal Button
H	Battery Door Skin	R	Trigger
I	E-STOP button	S	Indicator Light
J	Operator Panel		

Features and Components

LD-250, LD-250 ESD

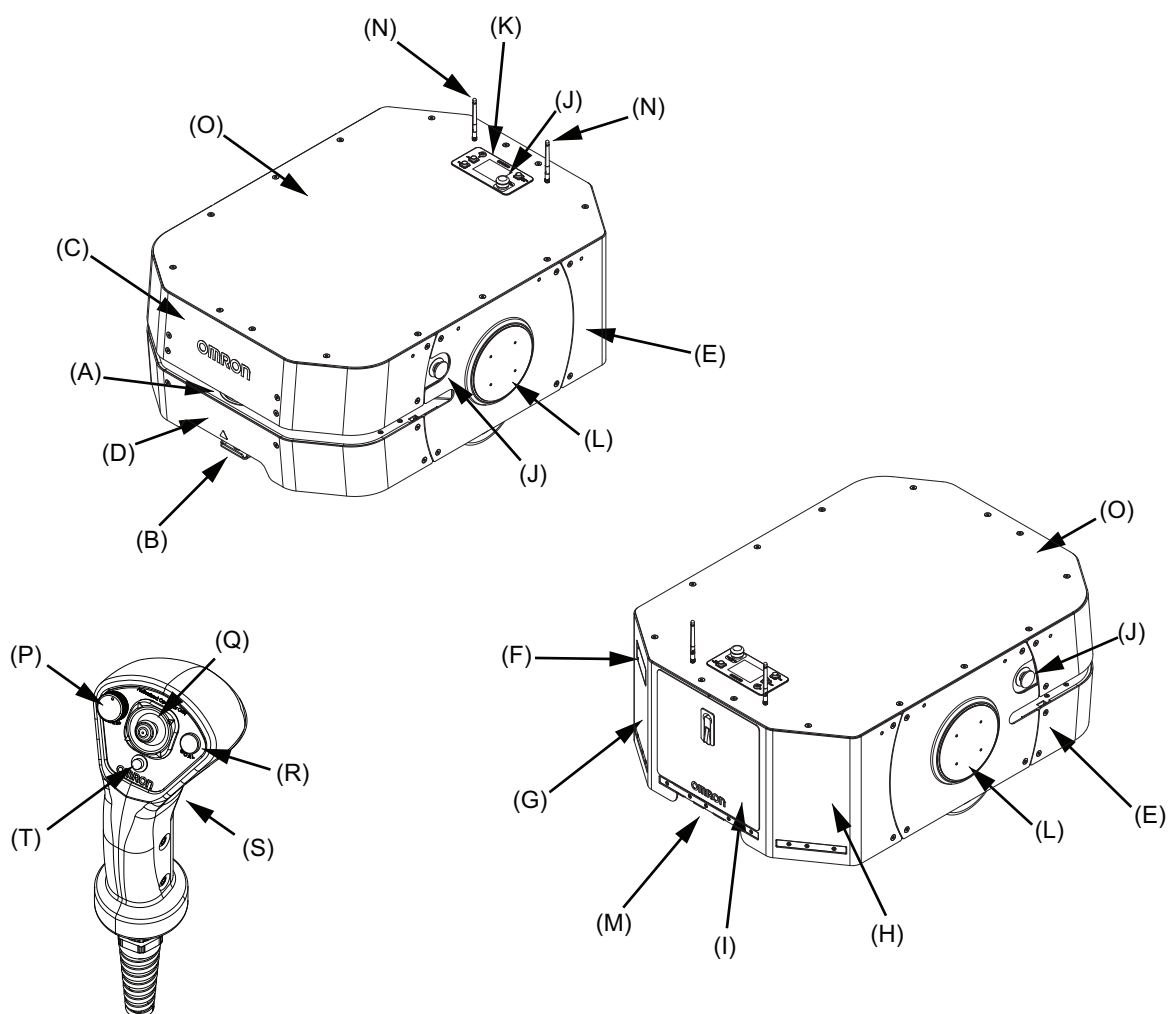

Item	Description	Item	Description
A	Safety Laser Scanner	K	Operator Panel
B	Low Laser	L	Light Disk
C	Upper Front Skin	M	Charging Contacts
D	Bumper Skin	N	Wireless Antennas
E	Side Skin	O	Payload Mounting Surface (Top Plate shown)
F	Access Panel	P	Speed Control
G	Left Rear Skin	Q	Directional Control Stick
H	Right Rear Skin	R	Goal Button
I	Battery Door Skin	S	Trigger
J	E-STOP button	T	Indicator Light

LD Series

Specifications

LD-60, LD-90, LD-90x, LD-60 ESD, LD-90 ESD, and LD-90x ESD

Item		LD-60	LD-90	LD-90x
Weight (with Battery)		62 kg		
Environment	Ambient temperature	5 to 40°C		
	Ambient humidity	5 to 95% (non-condensing)		
	Operating Environment	Indoor usage only, no excessive dust, no corrosive gas or liquid. Floor must be free of water, oil, dirt, and debris. Direct sunlight may cause safety laser false positives.		
	Ingress Protection Class	IP20		
	Cleanroom rating	ISO 5 / Class 100		
Floor Conditions	Minimum floor flatness	F _r 25 (ACI 117 standard)		
	Traversable step	15 mm max. *1	10 mm max. *1	
	Traversable gap	15 mm max. *2		
	Maximum Slope	Up to 60 kg: 4.8° / 8.3% incline Over 60 kg: Level floor only		
	Minimum floor compressive strength	5 Mpa		
Navigation	Routing	Autonomous routing by localizing with safety scanning laser based on environment mapping		
	Environmental map making method	Scan by walking the AMR through the environment, and upload the scan data to the MobilePlanner software		
	Low Front Laser	One Class 1 laser at front of AMR with a 126° field of view		
	Side Laser (optional)	Two Class 1 lasers with a 270° field of view on the sides of payload structure, user-mounted		
Visual Indicators		Light discs are located on the sides of the AMR. Additional indicators can be added.		
Payload	Maximum Weight	60 kg	90 kg	
Mobility	Run time (no payload)	15 h approx.		20 h approx.
	Run Time (full payload)	12 h approx.		15 h approx.
	Maximum Speed	1800 mm/s	1350 mm/s	900 mm/s
	Maximum Rotation Speed	180 °/s		
	Stop Position Repeatability (single AMR) *3	<ul style="list-style-type: none"> · To a position: ±65 mm · To standard target: ±25 mm, ±2° · With CAPS: ±8 mm, ±0.5° · With HAPS: ±8 mm, ±0.4° 		
	Stop Position Repeatability (Fleet) *3	<ul style="list-style-type: none"> · To a position: ±85 mm · To standard target: ±35 mm, ±2° · With CAPS: ±12 mm, ±0.5° · With HAPS: ±10 mm, ±0.5° 		
Drive wheels	Materials	Solid aluminum with non-marking, non-conductive, foam-filled rubber tread		
Passive casters	Materials	Conductive thermoplastic rubber on polyolefin		
Auxiliary Power		5 VDC±5%, 1 A switched Aux power 12 VDC±5%, 1 A switched Aux power 20 VDC±5%, 1 A switched Aux power 22 to 30 VDC, 4 A switched 22 to 30 VDC, 10 A switched 22 to 30 VDC, 10 A safe, switched 10 A switched and 10 A safe switched are from the same source and pass through the same 10 A fuse, so the sum of their current must be less than 10 A.		
Standards	AMR	EN ISO 12100, EN ISO 13849-1, EN 60204-1, EN 1525, ANSI B56.5, ISO 10218/ CSA Z434, EN 61000-6-2, EN 61000-6-4		
	Battery	EN ISO 12100, UN 38.3, EN 61000-6-2, EN 61000-6-4, UL 2271		
	Docking Station	EN ISO 12100, UL1012/CSA C22.2.107.2, IEC 60204-1, EN 61000-6-2, EN 61000-6-4		
	Wireless	IEEE 802.11 a/b/g		
Safety Features	Safety Scanning Laser	One at front of AMR Class 1 PLd safety per ISO13849-1 240° field of view		
	E-STOP Buttons	One on Operator Panel, additional E-STOP buttons can be added to the payload structure		
	Rear Sonar	Two at rear of AMR, 2 m range. Each pair includes one emitter and one receiver working together.		
	Front Bumper	Two pairs of sensors at the front of the AMR		
	Audible Indicators	Two speakers are included. Additional buzzers can be added.		

Item		LD-60	LD-90	LD-90x
Operator Interface	Display	8.89 cm diagonal TFT, 320 x 240 pixels, color screen		
	Button	ON button, OFF button, Brake-release button, and keyed mode selection		
User Interface	Wireless	802.11 a/b/g		
	Ethernet	One TCP/UDP interface (maintenance LAN), Auto-MDIX		
	Serial	Two serial communication interfaces		
	Digital I/O	16 inputs, 16 outputs		
	Audio	Digital audio in / out		

*1. A speed of 250 mm/s is recommended for traversing steps, and routine driving over steps should be avoided. Lower speeds may not traverse the step. Faster or frequent driving over steps will shorten the lifespan of the drivetrain components. All steps should have smooth, rounded profiles.

*2. AMR maximum speed is recommended for traversing gaps, and routine driving over gaps should be avoided. Lower speeds may not traverse the gap. Faster or frequent driving over gaps will shorten the lifespan of the drivetrain components.

*3. Stop position repeatability values were obtained using default AMR parameters and a map created by the LD-series AMR.

LD-250, LD-250 ESD Specifications

Item		LD-250
Weight (with battery)		148 kg
Environment	Ambient temperature	5 to 40°C
	Ambient humidity	5 to 95% (non-condensing)
	Operating Environment	Indoor usage only, no excessive dust, no corrosive gas or liquid. Floor must be free of water, oil, dirt, and debris. Direct sunlight may cause safety laser false positives.
	Ingress Protection Class	IP20
	Cleanroom rating	ISO 5 / Class 100
Floor Conditions	Minimum floor flatness	F=25 (ACI 117 standard)
	Traversable step	10 mm max. *1
	Traversable gap	15 mm max. *2
	Maximum Slope	Max. 1.7° / 3% incline
	Minimum floor compressive strength	5 Mpa
Navigation	Routing	Autonomous routing by localizing with safety scanning laser based on environment mapping
	Environmental map making method	Scan by manually driving the AMR through the environment, and upload the scan data to the MobilePlanner for map creation.
	Low Front Laser	One Class 1 laser at front of AMR with a 126° field of view
	Side Laser (optional)	Two Class 1 lasers with a 270° field of view on the sides of payload structure, user-mounted
Visual Indicators		Light discs are located on the sides of the AMR. Additional indicators can be added.
Payload	Maximum Weight	250 kg
Mobility	Run time (no payload)	13 h approx.
	Run Time (full payload)	10 h approx.
	Maximum Speed	1200 mm/s
	Maximum Rotation Speed	120 °/s
	Stop Position Repeatability (single AMR) *3	<ul style="list-style-type: none"> · To a position: ±75 mm · To standard target: ±25 mm, ±2° · With CAPS: ±8 mm, ±0.5° · With HAPS: ±8 mm, ±0.4°
	Stop Position Repeatability (Fleet) *3	<ul style="list-style-type: none"> · To a position: ±100 mm · To standard target: ±35 mm, ±2° · With CAPS: ±14 mm, ±0.6° · With HAPS: ±10 mm, ±0.6°
Drive wheel	Materials	Aluminum with polyurethane tread
Passive caster	Materials	Elastomer (Polyurethane)
Auxiliary Power		5 VDC±5%, 1 A switched Aux power 12 VDC±5%, 1 A switched Aux power 20 VDC±5%, 1 A switched Aux power 22 to 30 VDC, 4 A switched × 2 22 to 30 VDC, 10 A switched 22 to 30 VDC, 10 A safe, switched 10 A switched and 10 A safe switched are drawn from the same source, and pass through the same 10 A fuse, so the sum of their current must be less than 10 A.

LD Series

Item		LD-250
Standards	AMR	EN ISO 12100, EN ISO 13849-1, EN 60204-1, EN 1525, ANSI B56.5, ISO 10218/CSA Z434, EN 61000-6-2, EN 61000-6-4
	Battery	EN ISO 12100, UN 38.3, EN 61000-6-2, EN 61000-6-4, UL 2271
	Docking Station	EN ISO 12100, UL1012/CSA C22.2.107.2, IEC 60204-1, EN 61000-6-2, EN 61000-6-4
	Wireless	IEEE 802.11 a/b/g
Safety Features	Safety Scanning Laser	One at front of AMR Class 1 PLd safety per ISO13849-1 240° field of view
	E-STOP Buttons	One at Operator Panel, one on each side. Additional E-STOP buttons can be added to the payload structure
	Rear Sensing	Time of flight (TOF) sensors
	Audible Indicators	Two speakers are included. Additional buzzers can be added
Operator Interface	Display	3.5 inch TFT, 320 x 240 pixels, color screen
	Button	ON button, OFF button, Brake-release button, and keyed mode selection
User Interface	Wireless	802.11 a/b/g
	Ethernet	One TCP/UDP interface (maintenance LAN), Auto-MDIX
	Serial	Two serial communication interfaces
	Digital I/O	16 inputs, 16 outputs
	Audio	Digital audio in / out

*1. A speed of 600 mm/s is recommended for traversing steps, and routine driving over steps should be avoided. Lower speeds may not traverse the step. Faster or frequent driving over steps and gaps will shorten the lifespan of the drivetrain components. All steps should have smooth, rounded profiles.

*2. AMR maximum speed is recommended for traversing gaps, and routine driving over gaps should be avoided. Lower speeds may not traverse the gap. Faster or frequent driving over gaps will shorten the lifespan of the drivetrain components.

*3. Stop position repeatability values were obtained using default AMR parameters and a map created by the LD-series AMR.

Virtual Fleet Manager Software Minimum Hardware Requirements

Fleet Size / AMR Count	Small / ≤ 5	Medium ≤ 15	Large ≤ 30	X-Large ≤ 100
Virtual CPU	2 cores		4 cores	
Clockspeed	4GHz	8 GHz	12 GHz	16 GHz
Virtual RAM	8 GB	16 GB	24 GB	32 GB
Virtual Disk	512 GB			1 TB
FLOW software version	Minimum FLOW Core 4.0			

Note: The PC/IPC/Server is supplied by the user.

EM2100 Appliance

Weight	9.1 kg
Mounting method	1U rack mount in a standard 19-inch equipment rack
Power Supply	100 to 240 VAC (typical 100 W)
Power Consumption	200 W max.
Operating Temperature	10 to 35°C
Storage Temperature	-25 to 60°C
Operating Humidity	8 to 90%, non-condensing
Storage Humidity	5 to 95%, non-condensing
Chassis Ingress Protection Class	IP20
CPU	Intel® Xeon® CPU
Main Memory	32 GB DDR3
Storage	60 GB SSD
Archive Storage	4 TB HDD
Communication ports	Four 10/100/1000 Ethernet Four USB One VGA
Status Display	Multi-segment LCD

High Accuracy Positioning System (HAPS)

Sensor	Depth	30 mm
	Width	160 mm
	Ingress Protection Class	IP64
	Environment	-40 to 85°C
	LEDs	Power, tape present, left marker, right marker
Magnetic Tape	Width	25 mm
	Orientation	South up
Markers (Magnetic Tape)	Width	25 mm
	Length	300 mm min. for 500 mm/s drive speed
	Orientation	North up
	Separation From Tape	15 to 30 mm
Connections	Front Sensor	RS232-1 (/dev/ttyUSB9) on the core
	Rear Sensor	RS232-2 (/dev/ttyUSB10) on the core
	Power, Both Sensors	Aux power using the included splitter cable
Stop Position Repeatability, LD-60, LD-90 *	Single AMR	±8 mm position, 0.4° rotation
	Fleet	±10 mm position, 0.5° rotation
Stop Position Repeatability, LD-250 *	Single AMR	±8 mm position, 0.4° rotation
	Fleet	±10 mm position, 0.6° rotation

* Stop position repeatability values were obtained using default AMR parameters and a map created by the LD-series AMR.

Cell Alignment Positioning System (CAPS)

Stop Position Repeatability, LD-60, LD-90, LD-90x *	Single AMR	±8 mm position, 0.5° rotation
	Fleet	±12 mm position, 0.5° rotation
Stop Position Repeatability, LD-250 *	Single AMR	±8 mm position, 0.5° rotation
	Fleet	±14 mm position, 0.6° rotation
Type	Software license	

* Stop position repeatability values were obtained using default AMR parameters and a map created by the LD-series AMR.

Battery

Type	Lithium-Ion (LiFePO4)
Weight	19 kg
Voltage	22 to 30 VDC (25.6 VDC nominal)
Capacity	72 Ah (battery cell nominal)
Recharge Time	2 hrs. 10 min. for 20% to 80% charge
Ingress Protection Class	IP20
Recharge Cycles	Approximately 2000 cycles *
Charging Method	Automatic or manual

* Approximately 80% of nominal battery capacity will be available after using the battery at 90% depth of discharge at temperatures between 15°C to 35°C, charging and discharging at a 1C rate.

Docking Station

Current	8 A *
Power	100 to 240 VAC, 50 to 60 Hz
Power Consumption	800 W
Humidity	5 to 95L%, non-condensing
Temperature	5 to 40° C
Dimensions (W × D × H)	349 × 369 × 315 mm
	495 × 495.5 × 317 mm (with floor plate)
Weight	8.2 kg
Mounting	Wall bracket, directly to floor, or on floor with floor plate
Indicators	Power on: blue Charging: yellow
Connector	For out-of-AMR battery charging

* Circuit breaker built into AC power switch

Joystick (Pendant)

Weight	0.55 kg
IP Rating	IP56

Acuity Localization

Field of View	140°
Power Input	12 VDC (±10%) supplied from AMR through power connector
Power Consumption	3.3 W maximum

MobilePlanner Software

CPU	1.5 GHz dual-core CPU recommended
Main Memory	1.5 GB min. (4 GB min. recommended)
Hard Disk	At least 200 MB of available space
Video Memory	256 MB min.
Display	XGA 1024 × 768, 16 million colors
Supported Languages	English, Japanese, German, French, Italian, Korean, Spanish, Polish, Simplified Chinese, Traditional Chinese

LD Series

Dimensions

CAD data can be downloaded from https://robotics.omron.com/browse-documents/dir_id=10:
<http://www.adept.com/Robots-CAD-File>

(Unit: mm)

LD-60, LD-90, LD-90x, LD-60 ESD, LD-90 ESD and LD-90x ESD

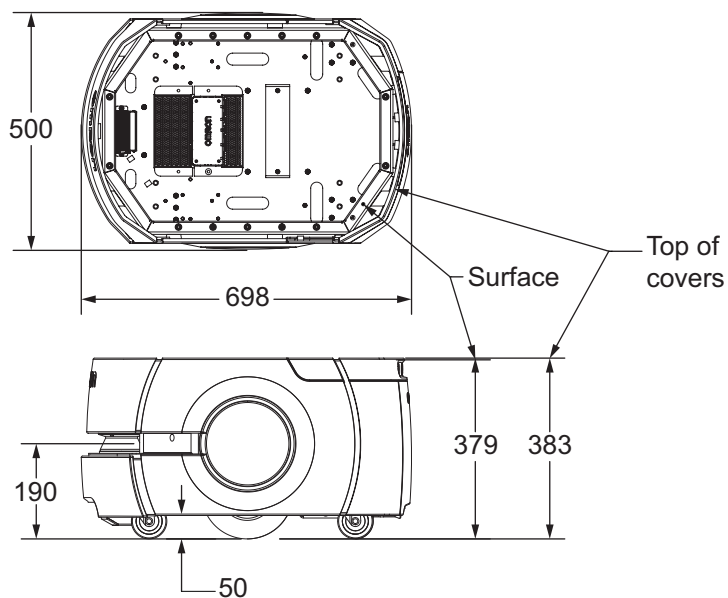

LD-250, LD-250 ESD

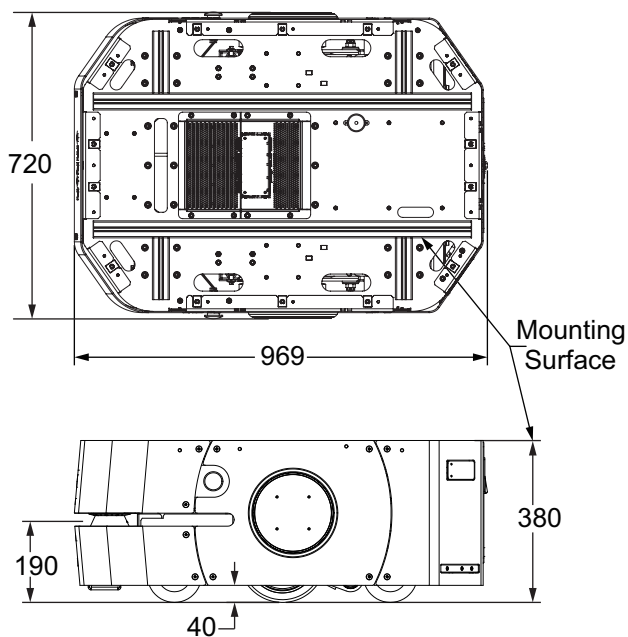

Dimensions

EM2100 Appliance

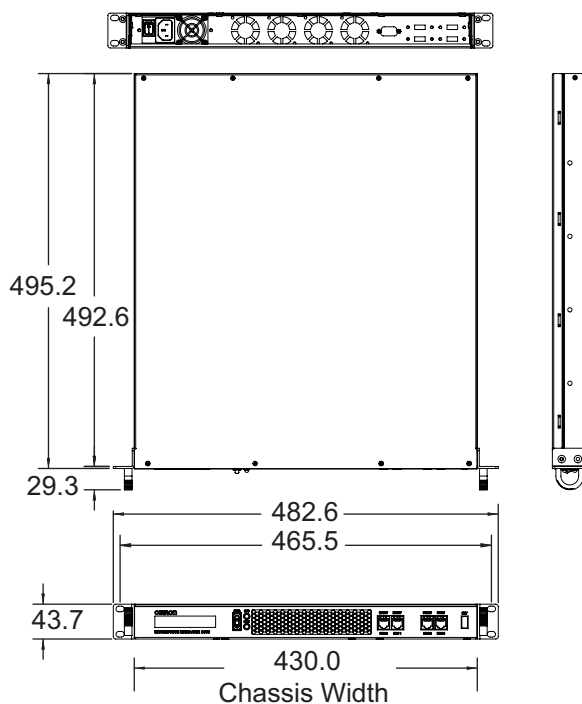

High Accuracy Positioning System (HAPS)

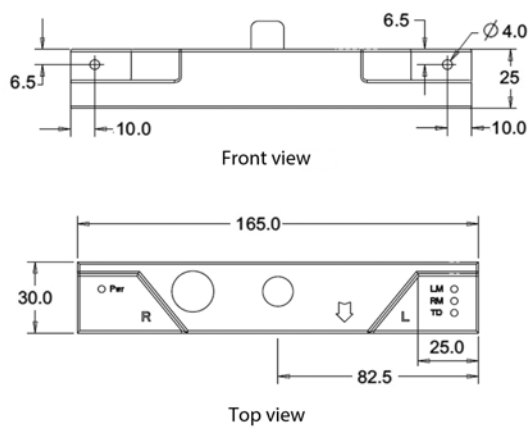

Acuity Localization

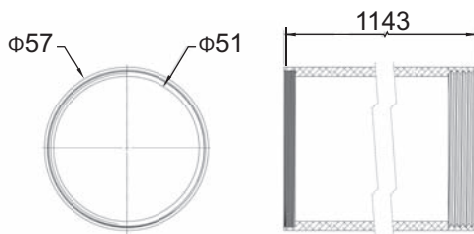

LD Series

Dimensions

(Unit: mm)

Docking Station

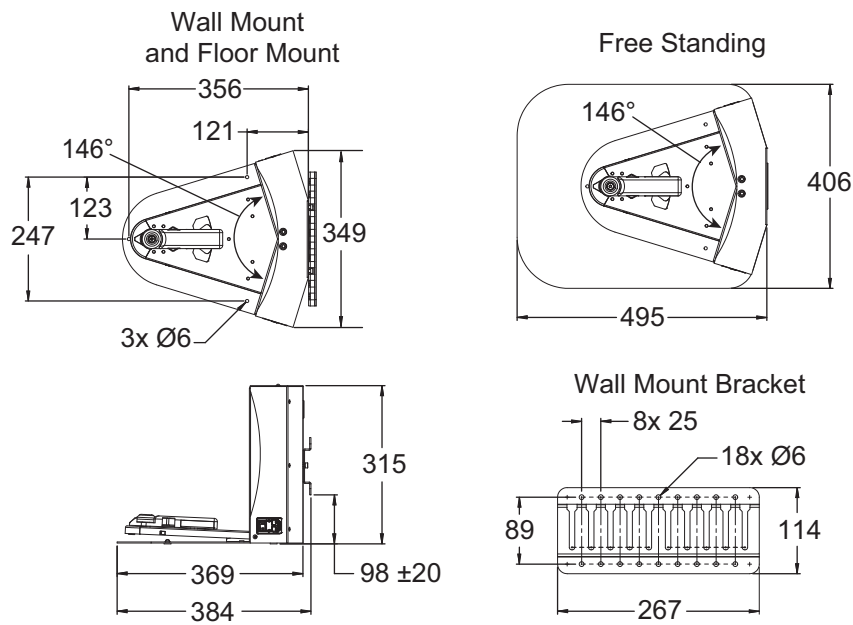

Joystick (Pendant)

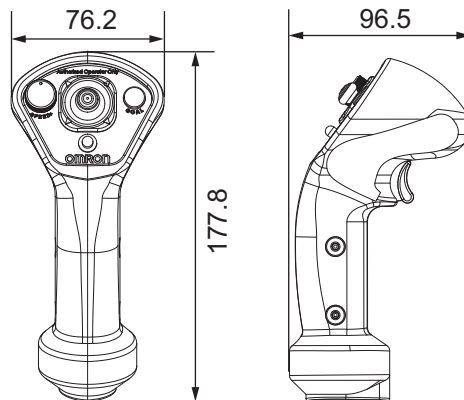

Related Manuals

Catalog Number	Manual Title
I611	LD-60/90 Platform User's Manual
I613	LD Platform Peripherals User's Guide
I614	Mobile Robot Software Suite User's Guide
I615	Enterprise Manager User Guide (this covers the EM1100, not the EM2100)
I616	Mobile Robot LD Safety Guide
I617	Advanced Robotics Command Language Reference Guide
I618	Advanced Robotics Command Language Fleet Manager - Mobile Robots Integration Guide
I634	EM2100 Installation Guide
I635	Fleet Operations Workspace Core User's Manual
I636	Fleet Operations Workspace Core Migration Guide
I637	Fleet Operations Workspace Core Integration Toolkit User Guide
I665	Fleet Operations Workspace iQ User's Manual
I649	Fleet Simulator User's Manual
I695	Virtual Fleet Manager Installation Guide
I642	LD-250 Platform User's Manual
I677	Mobile I/O Box User's Manual
I680	LD-Series Integration Guide

- Intel, Xeon and Intel Xeon are trademarks of Intel Corporation in the U.S. and/or other countries.
- Other company names and product names in this document are the trademarks or registered trademarks of their respective companies.
- The product photographs and figures that are used in this catalog may vary somewhat from the actual products.
- Microsoft product screen shot(s) reprinted with permission from Microsoft Corporation.

Terms and Conditions Agreement

Read and understand this catalog.

Please read and understand this catalog before purchasing the products. Please consult your OMRON representative if you have any questions or comments.

Warranties.

- (a) Exclusive Warranty. Omron's exclusive warranty is that the Products will be free from defects in materials and workmanship for a period of twelve months from the date of sale by Omron (or such other period expressed in writing by Omron). Omron disclaims all other warranties, express or implied.
- (b) Limitations. OMRON MAKES NO WARRANTY OR REPRESENTATION, EXPRESS OR IMPLIED, ABOUT NON-INFRINGEMENT, MERCHANTABILITY OR FITNESS FOR A PARTICULAR PURPOSE OF THE PRODUCTS. BUYER ACKNOWLEDGES THAT IT ALONE HAS DETERMINED THAT THE PRODUCTS WILL SUITABLY MEET THE REQUIREMENTS OF THEIR INTENDED USE.

Omron further disclaims all warranties and responsibility of any type for claims or expenses based on infringement by the Products or otherwise of any intellectual property right. (c) Buyer Remedy. Omron's sole obligation hereunder shall be, at Omron's election, to (i) replace (in the form originally shipped with Buyer responsible for labor charges for removal or replacement thereof) the non-complying Product, (ii) repair the non-complying Product, or (iii) repay or credit Buyer an amount equal to the purchase price of the non-complying Product; provided that in no event shall Omron be responsible for warranty, repair, indemnity or any other claims or expenses regarding the Products unless Omron's analysis confirms that the Products were properly handled, stored, installed and maintained and not subject to contamination, abuse, misuse or inappropriate modification. Return of any Products by Buyer must be approved in writing by Omron before shipment. Omron Companies shall not be liable for the suitability or unsuitability or the results from the use of Products in combination with any electrical or electronic components, circuits, system assemblies or any other materials or substances or environments. Any advice, recommendations or information given orally or in writing, are not to be construed as an amendment or addition to the above warranty.

See <http://www.omron.com/global/> or contact your Omron representative for published information.

Limitation on Liability: Etc.

OMRON COMPANIES SHALL NOT BE LIABLE FOR SPECIAL, INDIRECT, INCIDENTAL, OR CONSEQUENTIAL DAMAGES, LOSS OF PROFITS OR PRODUCTION OR COMMERCIAL LOSS IN ANY WAY CONNECTED WITH THE PRODUCTS, WHETHER SUCH CLAIM IS BASED IN CONTRACT, WARRANTY, NEGLIGENCE OR STRICT LIABILITY.

Further, in no event shall liability of Omron Companies exceed the individual price of the Product on which liability is asserted.

Suitability of Use.

Omron Companies shall not be responsible for conformity with any standards, codes or regulations which apply to the combination of the Product in the Buyer's application or use of the Product. At Buyer's request, Omron will provide applicable third party certification documents identifying ratings and limitations of use which apply to the Product. This information by itself is not sufficient for a complete determination of the suitability of the Product in combination with the end product, machine, system, or other application or use. Buyer shall be solely responsible for determining appropriateness of the particular Product with respect to Buyer's application, product or system. Buyer shall take application responsibility in all cases.

NEVER USE THE PRODUCT FOR AN APPLICATION INVOLVING SERIOUS RISK TO LIFE OR PROPERTY OR IN LARGE QUANTITIES WITHOUT ENSURING THAT THE SYSTEM AS A WHOLE HAS BEEN DESIGNED TO ADDRESS THE RISKS, AND THAT THE OMRON PRODUCT(S) IS PROPERLY RATED AND INSTALLED FOR THE INTENDED USE WITHIN THE OVERALL EQUIPMENT OR SYSTEM.

Programmable Products.

Omron Companies shall not be responsible for the user's programming of a programmable Product, or any consequence thereof.

Performance Data.

Data presented in Omron Company websites, catalogs and other materials is provided as a guide for the user in determining suitability and does not constitute a warranty. It may represent the result of Omron's test conditions, and the user must correlate it to actual application requirements. Actual performance is subject to the Omron's Warranty and Limitations of Liability.

Change in Specifications.

Product specifications and accessories may be changed at any time based on improvements and other reasons. It is our practice to change part numbers when published ratings or features are changed, or when significant construction changes are made. However, some specifications of the Product may be changed without any notice. When in doubt, special part numbers may be assigned to fix or establish key specifications for your application. Please consult with your Omron's representative at any time to confirm actual specifications of purchased Product.

Errors and Omissions.

Information presented by Omron Companies has been checked and is believed to be accurate; however, no responsibility is assumed for clerical, typographical or proofreading errors or omissions.

Note: Do not use this document to operate the Unit. This document describes AMR functionality supported with FLOW v2.0.7.

OMRON Corporation Industrial Automation Company

Kyoto, JAPAN

Contact : www.ia.omron.com

Regional Headquarters

OMRON EUROPE B.V.

Wegalaan 67-69, 2132 JD Hoofddorp
The Netherlands
Tel: (31) 2356-81-300 Fax: (31) 2356-81-388

OMRON ASIA PACIFIC PTE. LTD.
438B Alexandra Road, #08-01/02 Alexandra
Technopark, Singapore 119968
Tel: (65) 6835-3011 Fax: (65) 6835-3011

OMRON ELECTRONICS LLC

2895 Greenspoint Parkway, Suite 200
Hoffman Estates, IL 60169 U.S.A.
Tel: (1) 847-843-7900 Fax: (1) 847-843-7787

OMRON ROBOTICS AND SAFETY TECHNOLOGIES, INC.
4225 Hacienda Drive, Pleasanton, CA 94588 U.S.A.
Tel: (1) 925-245-3400 Fax: (1) 925-960-0590

OMRON (CHINA) CO., LTD.

Room 2211, Bank of China Tower, 200 Yin Cheng Zhong Road,
PuDong New Area, Shanghai, 200120, China
Tel: (86) 21-6023-0333 Fax: (86) 21-5037-2388

Authorized Distributor:

©OMRON Corporation 2017-2024 All Rights Reserved.
In the interest of product improvement,
specifications are subject to change without notice.

Cat. No. I828-E-13 0524 (0117)

11970-520M