

CIMR-L

L1000A

High Performance Vector Control

- High starting torque (200%/0.3 Hz OLV, 200%/0 Hz CLV)
- Advanced auto-tuning for IM & PM motors
- Light load detection function for UPS
- Lift language (Hz, m/s, rpm, levelling speed...)
- Rescue operation function
- Overshoot and anti-vibration control
- Screw-less terminals
- Control terminals with memory backup
- Built-in braking transistor up to 30 kW unit
- Fieldbus communications: CANopen
- Safety embedded: ISO/EN13849-1/AC: 2009 PLe (Cat3), IEC EN 61508: 2010 SIL 3, IEC EN 62061: 2005 (SILCL3), IEC EN 61800-5-2: 2007 (SIL 3), IEC EN 61326-3-1: 2008 (EMC-related) and EN81-1/2/20
- Regenerative solutions as option
- CE, UL, cUL and TUV

Ratings

- 400 V class three-phase 1.5 to 110 kW



System configuration

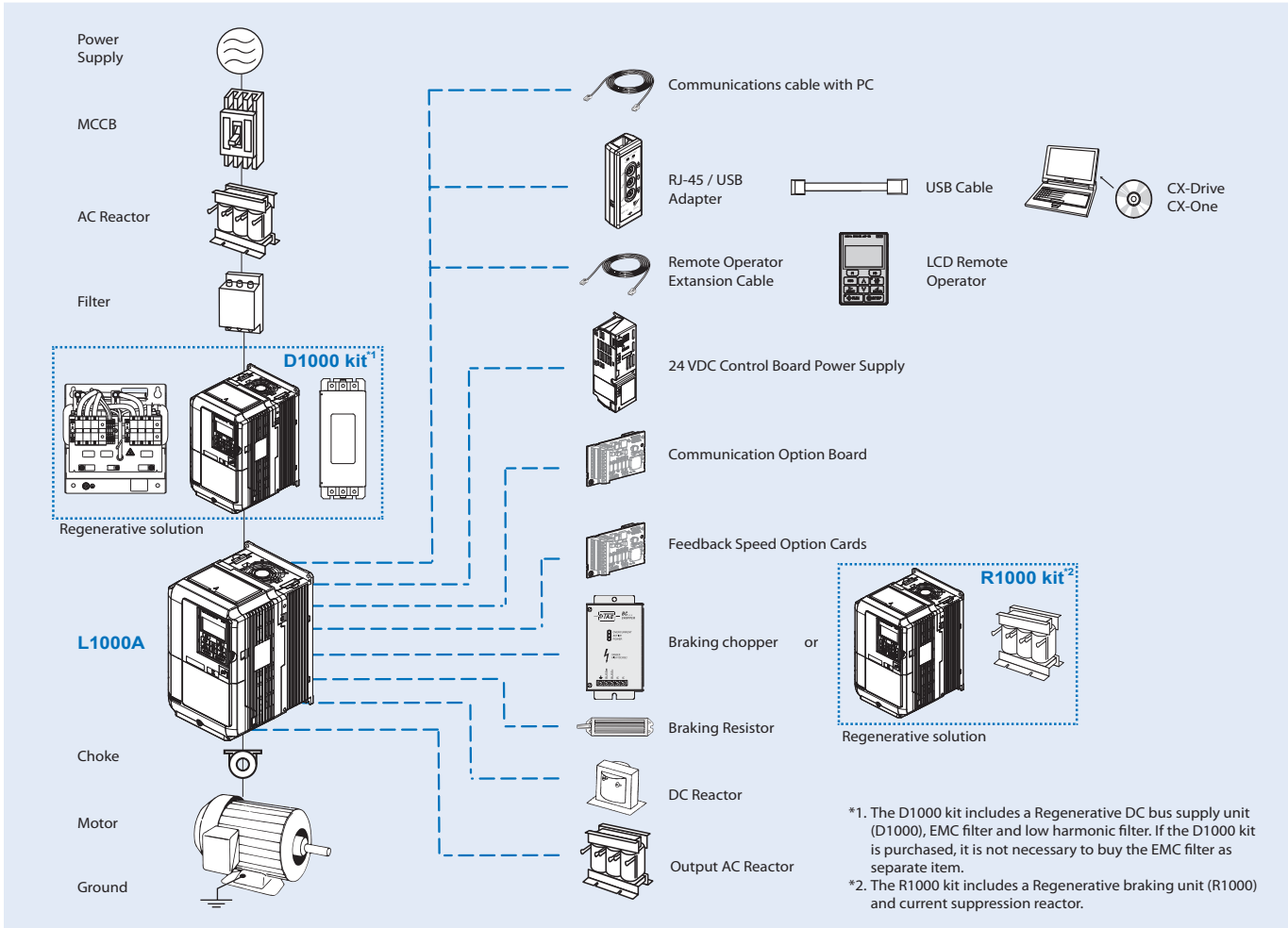

Specifications

Type designation

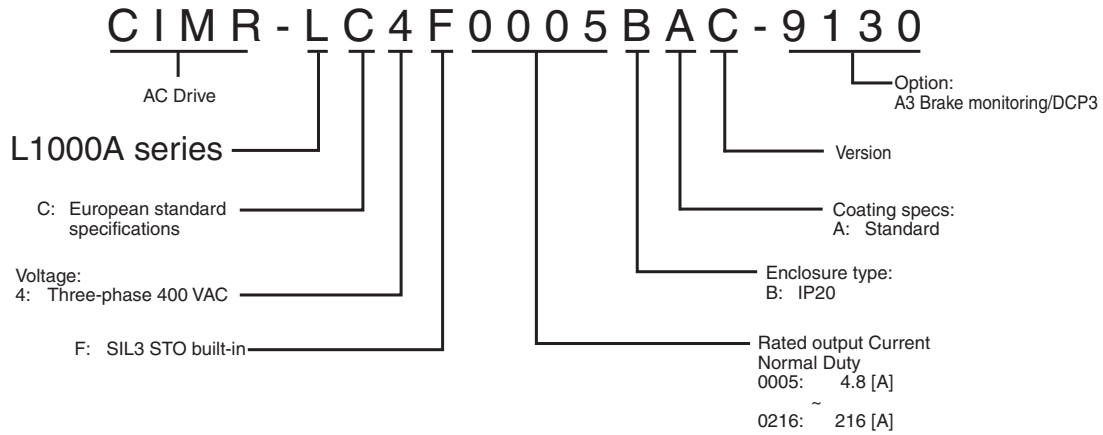

400 V class

Three-phase: CIMR-LC4F□		0005	0006	0009	0015	0018	0024	0031	0039	0045	0060	0075	0091	0112	0150	0180	0216
Motor kW ¹	For HD setting	1.5	2.2	4.0	5.5	7.5	11	15	18.5	22	30	37	45	55	75	90	110
	Drive capacity kVA ²	3.7	4.2	7	11.3	13.7	18.3	24	30	34	48	57	69	85	114	137	165
Output characteristics	Rated output current (A)	4.8 ³	5.5 ³	9.2 ³	14.8 ³	18 ³	24 ³	31 ³	39 ³	45 ³	60 ³	75 ³	91 ³	112 ⁴	150 ⁴	180 ⁴	216 ⁴
	Max. output voltage	Three-phase 380 to 480 V (proportional to input voltage)															
	Max. output frequency	200 Hz (user-adjustable)															
	Rated input voltage and frequency	Three-phase 380 to 480 VAC, 50/60 Hz															
Power supply	Allowable voltage fluctuation	-15% to 10%															
	Allowable frequency fluctuation	+5%															
	Input Current (A) ⁵	4.4	6	10.4	15	20	29	39	44	49	58	71	86	105	142	170	207

*1. Based on a standard 4-pole motor for maximum applicable motor output.
 *2. Rated Motor Capacity is calculated with a rated output voltage of 220 V.
 *3. Carrier frequency can be increased up to 8 kHz while keeping this current rating. Higher carrier frequency settings require derating.
 *4. Carrier frequency can be increased up to 5 kHz while keeping this current rating. Higher carrier frequency settings require derating.
 *5. Assumes operation at rated output current. Input current rating varies depending on the power supply transformer, input reactor, wiring conditions, and power supply impedance.

Specifications

Common specifications

Model number CIMR-LC	Specifications	
Control functions	Control methods	V/f control, Open loop vector control, Closed loop vector control, Closed loop vector control for PM
	Output frequency range	0.01 to 200 Hz
	Frequency tolerance	Digital set value: $\pm 0.01\%$ of the max. output frequency (-10 to 40 °C)
		Analogue set value: $\pm 0.1\%$ of the max. output frequency (25 ± 10 °C)
	Resolution of frequency set value	Digital set value: 0.01 Hz
		Analogue inputs: 1/2048 of the maximum output speed setting (11 bit plus sign)
	Resolution of output frequency	0.001 Hz
	Frequency set value	-10 to 10 V (20 k Ω), 0 to 10 V (20 k Ω)
	Starting torque	150%/3Hz (V/f control), 200%/0.3Hz (Open loop vector control), 200%/ 0 r/min (Closed loop vector control)
	Speed control range	1:1500 (Closed loop vector control), 1:200 (Open loop vector control), 1:40 (V/f control)
	Speed control accuracy	$\pm 0.2\%$ in Open loop vector control (25 ± 10 °C), 0.02% in Closed loop vector control (25 ± 10 °C)
	Speed response	10 Hz in Open loop vector control (25 ± 10 °C), 100 Hz in Closed loop Vector Control (25 ± 10 °C) (excludes temperature fluctuation when performing Rotational Auto-Tuning)
	Torque limit	Parameters setting allow separate limits in four quadrants (available in OLC, CLV, CLV/PM)
Accel/Decel time	0.00 to 6000.0 s (4 selectable combinations of independent acceleration and deceleration settings, unit changeable to m/s ² or ft/s ²)	
Braking transistor	Models CIMR-LC2F0008 to 2F0115, 4F0005 to 4F0060 have a built-in braking transistor.	
V/f characteristics	Freely programmable	
Functionality	Main control functions Inertia Compensation, Position Lock at Start and Stop/Anti-Rollback Function, Overtorque/Undertorque Detection, Torque Limit, Speed Reference, Accel/decel Switch, 5 Zone Jerk Settings, Auto-tuning (stationary and Rotational Motor/ Encoder Offset Tuning), Dwell, Cooling Fan on/off Switch, Slip Compensation, Torque Compensation, DC Injection Braking at Start and Stop, MEMOBUS/Modbus Comm (RS-422/485 max, 115.2 kbps), Fault Restart, Removable Terminal Block with Parameter Backup Function, Online Tuning, High Frequency Injection, Short Floor, Rescue Operation (Light Load Direction Search Function), Inspection Run, Brake Sequence, Speed related parameters with elevator unit display, etc.	
Protection functions	Motor protection	Electronic thermal overload relay
	Momentary overcurrent protection	Drive stops when output current exceeds 200% of rated output current
	Overload protection	Drive stops after 60 s at 150% of rated output current (Heavy Duty Rating)
	Overvoltage protection	Stops when DC bus exceeds approx. 820V
	Undervoltage protection	Stops when DC bus exceeds approx. 380V
	Heatsink overheat protection	Protected by thermistor
	Stall prevention	Stall Prevention is available during acceleration, and during run
	Ground fault	Electronic circuit protection
Ambient conditions	DC Bus charge LED	Remains lit until DC bus voltage falls below 50 V
	Area of use	Indoor (no corrosive gas, dust, etc.)
	Ambient temperature	-10°C to 50°C (open chassis)
	Ambient humidity	95% RH or less (without condensation)
	Storage temperature	-20°C to 60°C (short-term temperature during transportation)
Safety standard	Altitude	Up to 1000 m without derating, up to 3000 m with output current and voltage derating
	Vibration / shock	10 to 20 Hz, 9.8 m/s ² 20 to 55Hz, 5.9 m/s ²
Safety standard		Two Safe Disable inputs and 1 EDM output according to ISO/EN13849-1/AC: 2009 PL _e (Cat3), IEC EN 61508: 2010 SIL 3, IEC EN 62061: 2005 (SILCL3), IEC EN 61800-5-2: 2007 (SIL 3), IEC EN 61326-3-1: 2008 (EMC-related) and EN81-1/2/2. Insulation coordination: class 1 Note: Time from input open to drive output stop is less than 1 ms.
Protection design	IP20 enclosure	

Dimensions

Enclosed Panel [IP20]

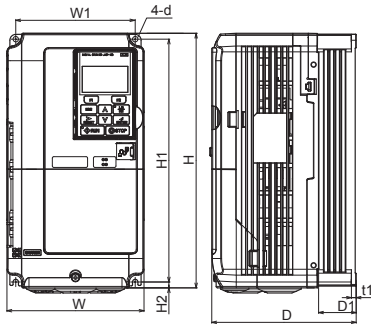

Figure 1

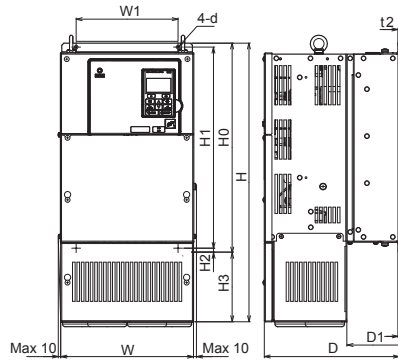

Figure 2

Voltage class	Max. applicable motor output kW	Drive model CIMR-LC□	Figure	Dimensions in mm												Weight (kg)						
				W	H	D	W1	H0	H1	H2	H3	D1	t1	t2	d							
Three-phase 400 V	1.5	4F0005	1	140	260	147	122	-	248	6	-	38	5	-	M5	3.2						
	2.2	4F0006				164										3.4						
	4.0	4F0009				167										3.5						
	5.5	4F0015														3.9						
	7.5	4F0018														180	300	160	284	8	75	5.4
	11	4F0024																				5.7
	15	4F0031	187	78	8.3																	
	18.5	4F0039	220	350	197	192	192	335	78	2.3	2.3	M6	23									
	22	4F0045	2	254	465	258	195	400	385				7.5	65	100	105	27					
	30	4F0060															279	515	220	450	435	120
	37	4F0075	329	630	260	510	495	120	105				80	110	43							
	45	4F0091														45						
	55	4F0112	283	550	535	80	110	45														
	75	4F0150							45													
	90	4F0180	450	705	330	325	705	680	12.5				163	130	3.2	3.2	M10	85				
	110	4F0216	500	800	350	370	800	773	13				238	4.5	4.5	M12	103					

Schaffner filters

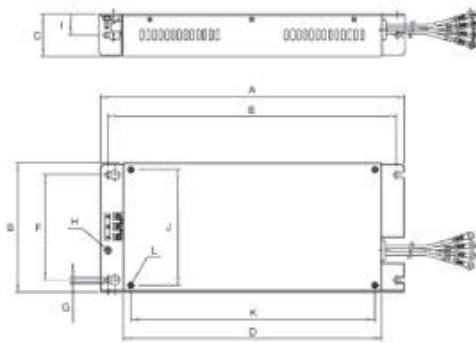

Figure 1

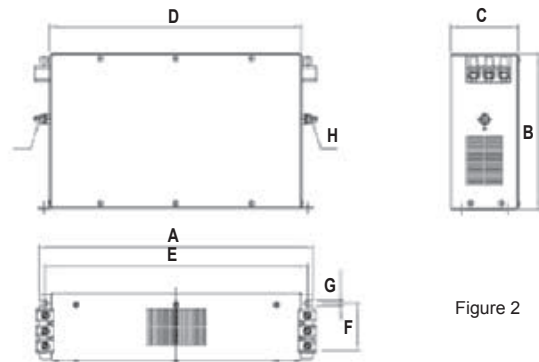
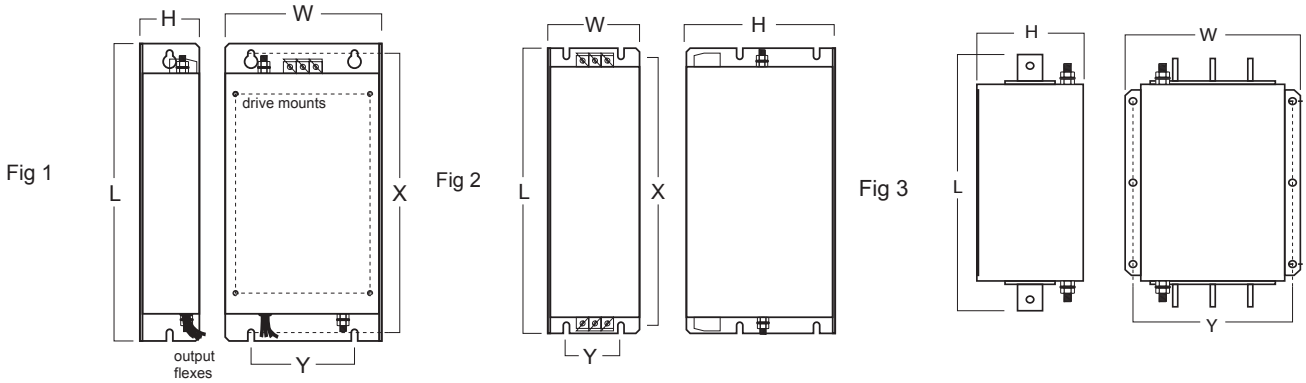

Figure 2

Bookform filters		Fig	Dimensions										Weight (kg)
			A	B	C	D	E	F	G	H	I	L	
400 V	3G3RV-PFI3010-SE	1	330	141	46	281	313	115	5.5	M4	23	M5	1.2
	3G3RV-PFI3018-SE		330	141	46	281	313	115	5.5	M4	23	M5	1.3
	3G3RV-PFI3035-SE		355	206	50	302	336	175	6.5	M5	25	M6	2.2
	3G3RV-PFI3060-SE		408	236	65	355	390	205	6.5	M6	32.5	M6	4
	3G3RV-PFI3100-SE	2	326	150	90	240	255	65	6.5	M10	-	-	4.5
	3G3RV-PFI3170-SE		451	170	120	350	365	102	6.5	M10	-	-	6.0
	3G3RV-PFI3200-SE		518	240	130	480	498	90	8.3	M10	-	-	11.7

Rasmi filters



Flat filters		Figure	Dimensions					Fixing	Weight (kg)
400 V			L	W	H	X	Y		
	A1000-FIA3024-RE ^{*1}	1	306	150	52	290	122	M5	2.0
	A1000-FIA3044-RE ^{*1}		357	182	62	330	160	M5	2.8
	A1000-FIA3052-RE ^{*1}		415	220	62	380	192	M6	3.9
	A1000-FIA3071-RE	2	329	80	220	314	55	M6	5.3
	A1000-FIA3105-RE		379	90	220	364	65	M6	6.5
	A1000-FIA3170-RE	3	429	110	240	414	80	M6	9
	A1000-FIA3300-RE		300	260	135	120	235	M10	13.2

*1. Footprint filter

Remote LCD operator

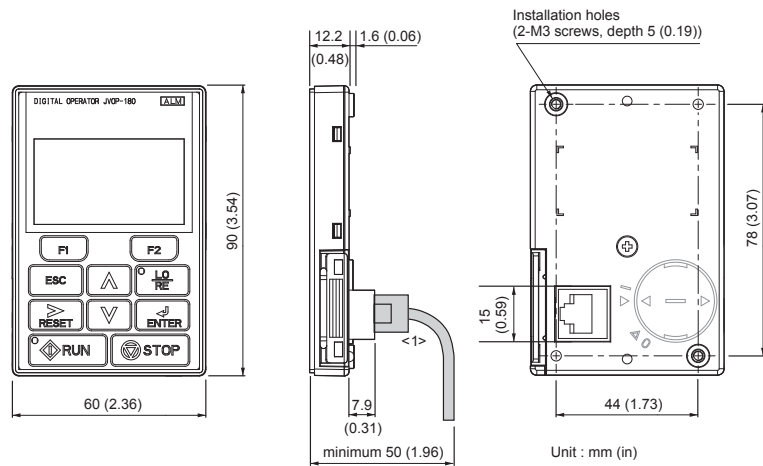

Chokes

Description	D diameter	Motor kW	Dimensions						Weight (kg)
			L	W	H	X	Y	m	
AX-FER2102-RE	21	< 2.2	85	22	46	90	-	5	0.1
AX-FER2815-RE	28.5	< 15	106	24	62	70	-	5	0.2
AX-FER5045-RE	50	< 45	150	50	112	125	30	5	0.7
AX-FER6055-RE	60	> 45	200	65	170	180	45	6	1.7

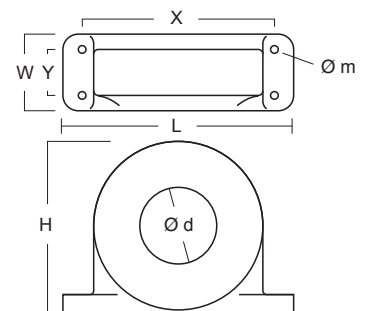

D1000 kit - DC Supply with Regenerative Active Front End

Regenerative DC bus supply unit (D1000)

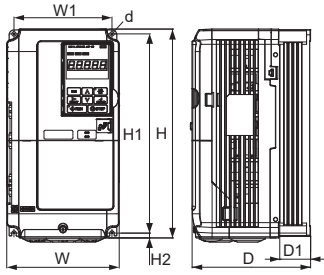

Figure 1

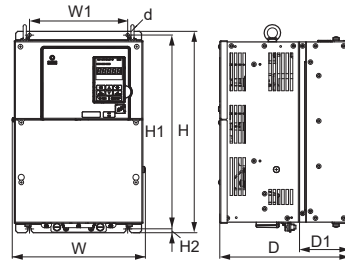

Figure 2

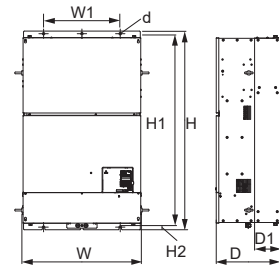

Figure 3

Voltage class	Model CIMR-DC□	Figure	IP	Dimensions in mm								Weight kg	
				W	H	D	W1	H1	H2	D1	d		
Three-phase 400 V	4A0005	1	20	180	300	187	160	284	8	75	M5	5	
	4A0010			220	365	197	192	335		78		8	
	4A0020	2	00	275	450	258	220	435	7.5	100	M6	21	
	4A0030			325	550	283	260	535		110		34	
	4A0040	3		500	800	350	370	773	13	130	M12	85	
	4A0060												
	4A0100												
4A0130													

EMC filter

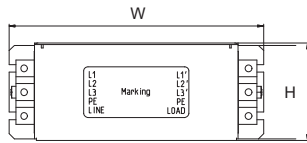

Figure 1

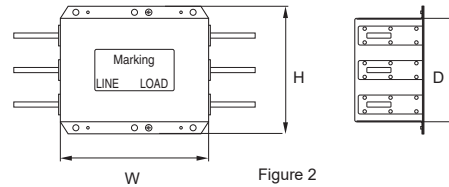
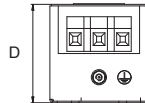

Figure 2

Model	Figure	Dimensions in mm			Weight kg
		W	H	D	
B84143A0020R106	1	386	200	202	0.6
B84143A0035R106		426	250	322	0.9
B84143A0065R106		436	310	432	1.9
B84143B0180S080	2	200	170	110	5.0
B84143B0400S080		290	190	116	7.5

Low harmonic filter

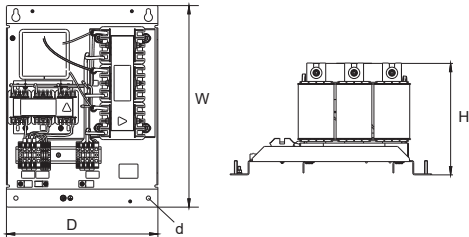

Figure 1

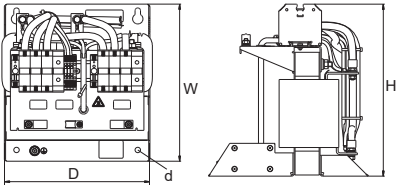

Figure 2a

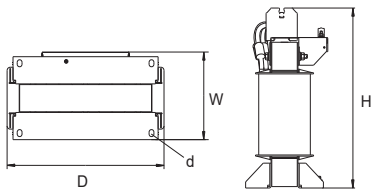

Figure 2b

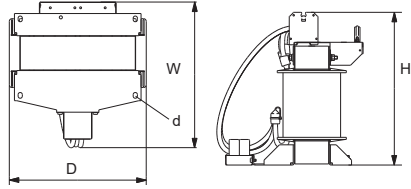

Figure 2c

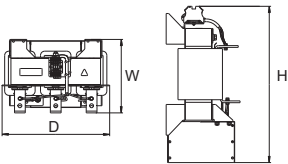

Figure 3a

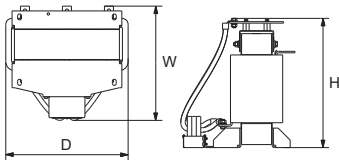

Figure 3b

Model	Component	Figure	Dimensions in mm				
			W	H	D	d (diameter)	Weight kg
B84143G0008R176		1	386	176 ±5	200	9	9
B84143G0016R176			426	234 ±5	320		18
B84143G0030R176							28
B84143G0043R176			436	286 ±5	430		37
B84143G0058R176							64
B84143G0086R176	Harmonic filter	2a	265	288 ±5	240	9	20
	10% choke	2b	149	max. 390	300	15 x 25	55
B84143G0145R176	Harmonic filter	2a	328	303 ±5	240	9	30
	10% choke	2c	max. 390	max. 405	max. 365	15 x 25	69
B84143G0210S176	Harmonic filter	3a	206 ±3	438	300	-	39
	10% choke	3b	max. 400	max. 445	max. 420	-	98

R1000 kit - Regenerative Braking unit

Regenerative Braking unit (R1000)

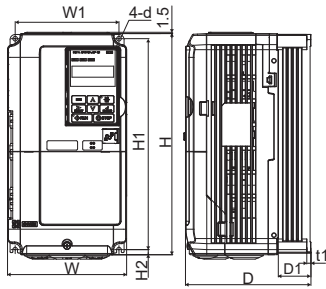

Figure 1

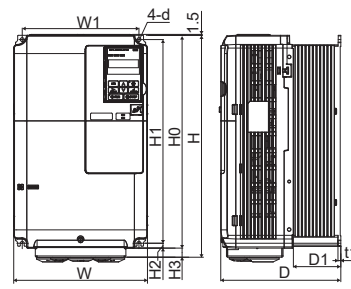

Figure 2

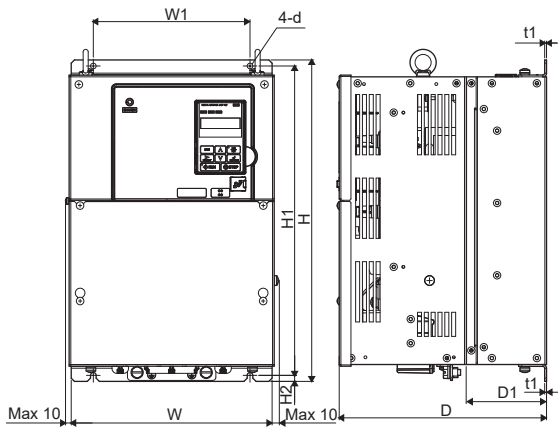

Figure 3

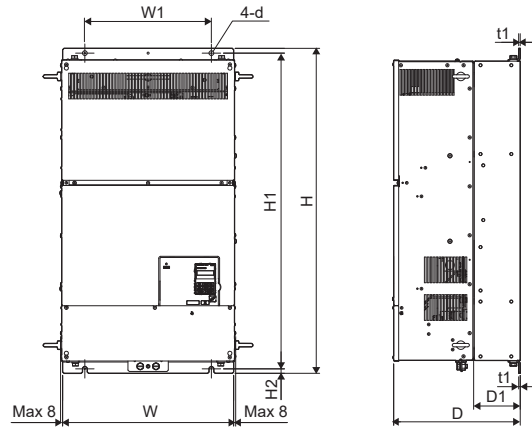

Figure 4

Voltage class	Model CIMR-RC□	Figure	IP	Dimensions in mm												
				W	H	D	W1	H0	H1	H2	H3	D1	t1	d	Weight kg	
Three-phase 400 V	4A03P5	1	20	140	260	167	122	-	248	6	-	55	5	M5	4	
	4A0005			180	300	187	160	-	284	8	-	75	M6	8		
	4A0007															
	4A0010															
	4A0014	2		220	365	197	192	350	355	15	78					
	4A0017															
	4A0020	3		00	275	450	258	220	-	435	7.5	-	100	2.3	M6	20
	4A0028				325	550	283	260	-	535	-	-	110	M10	62	
	4A0035															
	4A0043															
4A0053	4	450	705	330	325	-	680	13	-	130	3.2					
4A0073																
4A0105																

Current suppression reactor

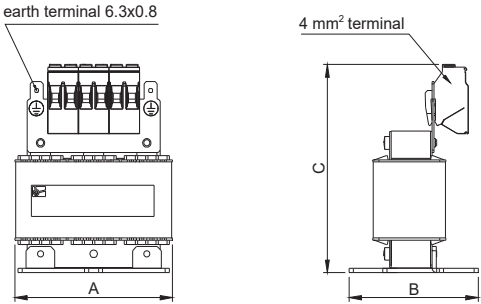

Figure 1

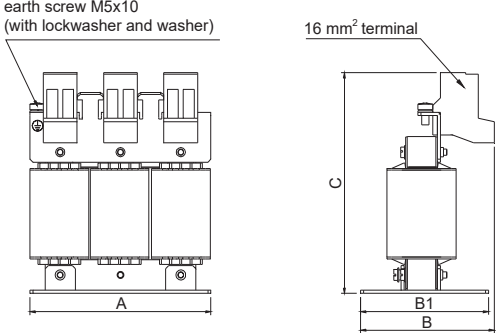

Figure 2

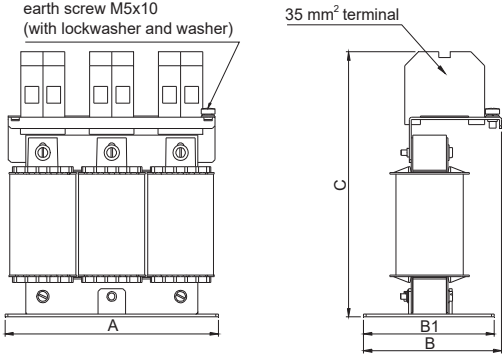

Figure 3

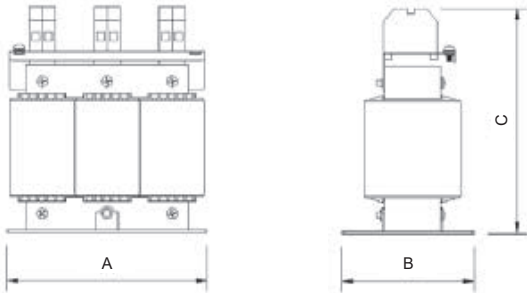

Figure 4

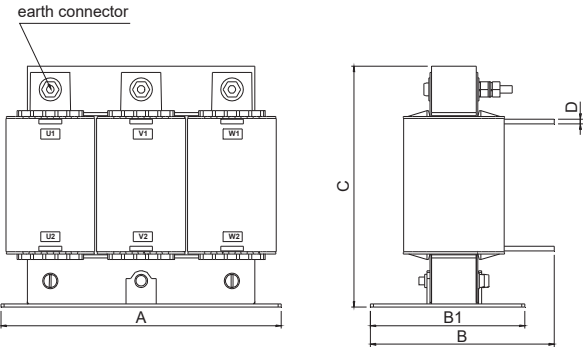
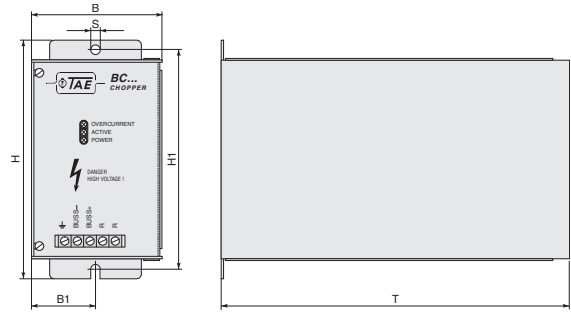

Figure 5

Model	Figure	Dimensions in mm					Weight kg
		A	B	B1	C	D	
B1509105	1	max. 78	63	-	102	-	0.85
B1509106		max. 96	60	-	118	-	1.31
B1509107		-	-	-	-	-	1.32
B1509108	2	120	max. 90	85	150	-	1.9
B1509109		-	-	-	-	-	1.93
B1509110	3	155	max. 102	95	195	-	3.8
B1504118	4	155	95	-	175	-	4.0
B1509111	3	155	max. 102	95	195	-	4.43
B1509112			110	-			5.95
B1509113	5	185	max. 125	102	160	3	6.9
B1509114			max. 140	122			10.8

Braking units

Reference	Dimensions					
	B	B1	H	H1	T	S
AX-BCR4035090-TE	130	64.5	205	193	208	6
AX-BCR4070130-TE						



Resistor

Fig 1

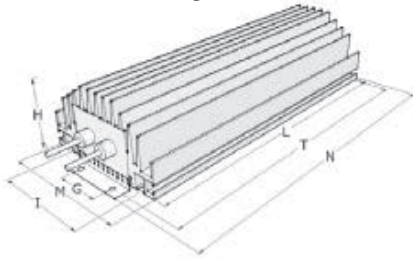

Fig 2

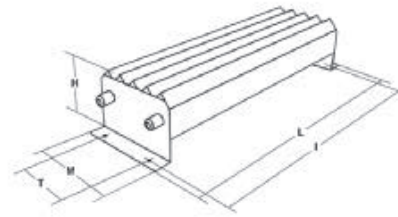

Fig 3

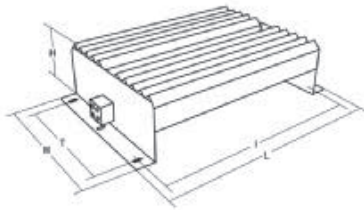
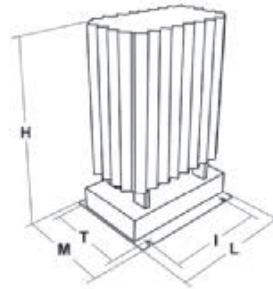

Fig 4



Type	Fig.	Dimensions							Weight (kg)
		L	H	M	I	T	G	N	
AX-REM00K9120-IE	1	200	61	100	74.5	216	40	230	1.41
AX-REM01K9040-IE	2	365	73	105	350	70	-	-	4
AX-REM03K5035-IE	3	365	100	240	350	210	-	-	8
AX-REM03K5025-IE									
AX-REM19K0020-IE	4	206	350	140	190	50	-	-	8.1
AX-REM19K0030-IE									
AX-REM38K0012-IE									

Installation

Standard connections

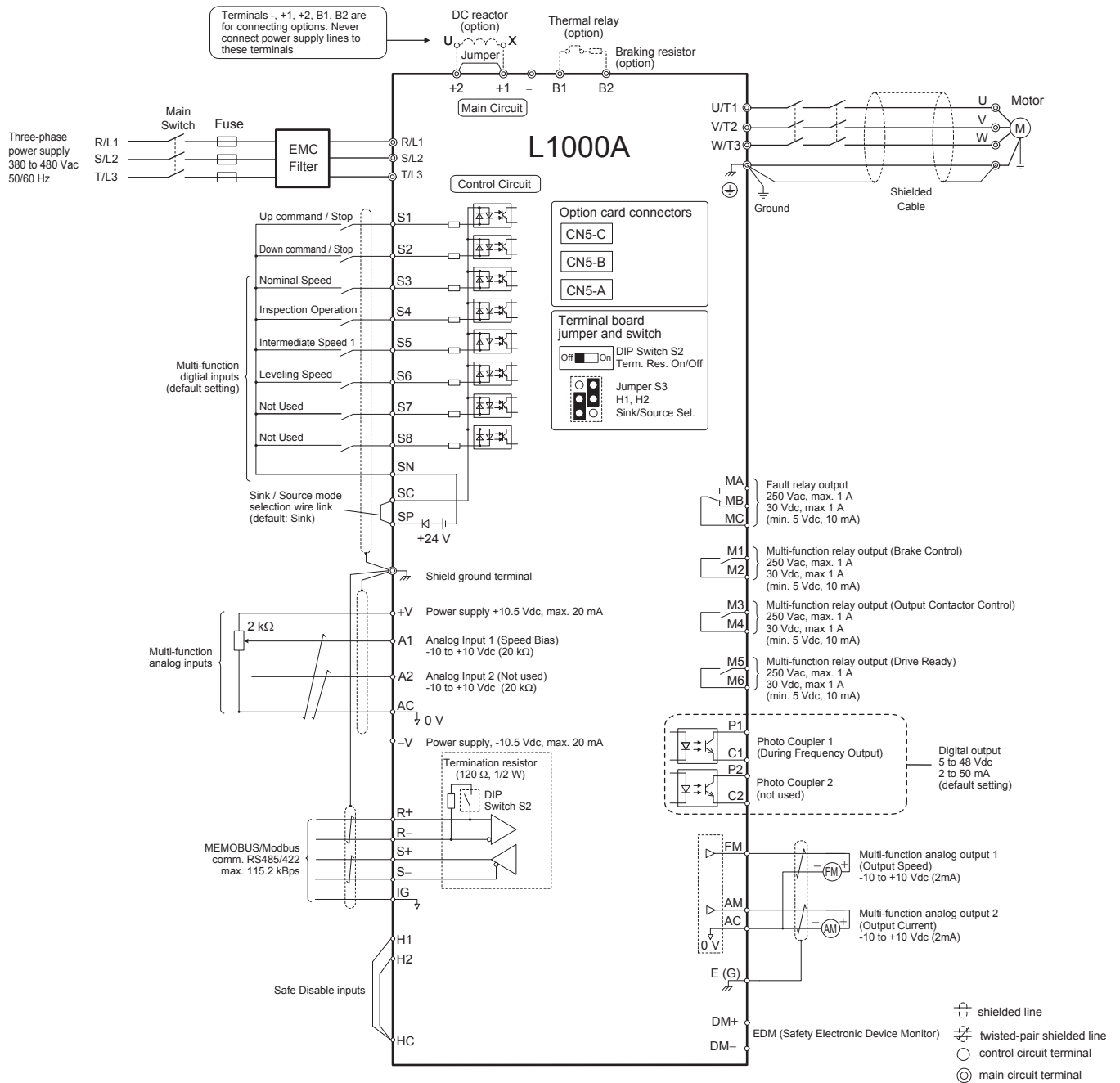

Main circuit

Terminal	Name	Function (signal level)
R/L1, S/L2, T/L3	Main circuit power supply input	Used to connect line power to the drive
U/T1, V/T2, W/T3	Drive output	Used to connect the motor
B1, B2	Braking resistor connection	Available for connecting a braking resistor or the braking resistor unit option
+2, +1	DC reactor connection	Remove the short bar between +2 and +1 when connecting DC reactor (option)
+1, -	DC power supply input	For power supply input (+1: positive electrode; - : negative electrode)
+3	Braking Unit	Connection for Braking Unit between terminals +3 and -
⊕	Grounding	For grounding (grounding should conform to the local grounding code)

Control Circuit

Type	No.	Signal name	Function	Signal level
Digital input signals	S1	Up Command	Closed: UP, Open: Stop	24 VDC, 8 mA photocoupler insulation
	S2	Down Command	Closed: Down, Open: Stop	
	S3	Multi-function input selection 3	Nominal speed	
	S4	Multi-function input selection 4	Inspection Operation	
	S5	Multi-function input selection 5	Intermediate Speed 1	
	S6	Multi-function input selection 6	Leveling Speed	
	S7	Multi-function input selection 7	Not used	
	S8	Multi-function input selection 8	Not used	
	SC	Multi-function input Common	Common for control signal	
	SN	0 V	Photocoupler, 24 VDC, 8mA Use the wire link between terminals SC and SN or between SC and SP to select sinking or sourcing, and to select the power supply.	
SP	+24 VDC			
Analog input signals	+V	Power Supply for analog inputs	+10.5 V (allowable max current 20 mA)	
	-V	Power Supply for analog inputs	-10.5 V (allowable max current 20 mA)	
	A1	Multi-function analogue input 1	Speed reference bias -10 to +10 VDC, 0 to +10 VDC (20 kΩ)	
	A2	Multi-function analogue input 2	Not used -10 to +10 VDC, 0 to +10 VDC (20 kΩ)	
	AC	Analog input common	0 V	
	E(G)	Ground for shielded lines and option cards		
Safety input	HC	Safe Disable function common	Common for the Safe Disable function	
	H1	Safe Disable input 1	24 VDC, 8mA (3.3 kΩ) Off time of at least 1ms	
	H2	Safe Disable input 2	Set the S3 jumper to select sinking or sourcing, and to select the power supply One of both open: Drive output disabled Both closed: Normal operation	
Safety monitor output	DM+	Safety monitor output	Outputs status of Safe Disable function. Closed when both Safe Disable channels are closed	48 VDC, 50mA or less
	DM-	Safety monitor output common		
Fault relay	MA	NO contact output	Factory setting: "fault"	Contact capacity 250 VAC, 10mA to 1A 30 VDC, 10mA to 1A Minimum load: 5VDC 10mA
	MB	NC output		
	MC	Fault output common		
Multi-function relay output	M1	Multi-function relay output 1	Factory setting: Brake release command	
	M2			
	M3	Multi-function relay output 2	Factory setting: Output contactor close command	
	M4			
	M5	Multi-function relay output 3	Factory setting: Drive ready	
	M6			
Multi-function photocoupler output	P1	Photocoupler output 1	Factory setting: During Frequency output)	48 VDC, 2 to 50mA
	C1			
	P2	Photocoupler output 2	Factory setting: Not Used / Through Mode	
	C2			
Analog output signals	FM	Multi-function analog monitor (1)	Factory setting: Output Speed	-10 to 10 V ±5%, (2 mA or less) 0 to 10 V 4 - 20 mA
	AM	Multi-function analog monitor (2)	Factory setting: Output Current	
	AC	Analog monitor common	0 V	
RS-485/422	R+	Communication input (+)	For MEMOBUS/Modbus communication: Use an RS-485 or RS-422 cable to connect the drive	RS-485/422 MEMOBUS/Modbus communication proto- col: 115.2 kbps max.
	R-	Communication input (-)		
	S+	Communication output (+)		
	S-	Communication output (-)		
	IG	Shield ground		

Drive heat loss

Three-phase 400 V class

Model Number CIMR-LC□	Heavy Duty			
	Rated Amps (A)	Heatsink Loss (W)	Interior Unit Loss (W)	Total Loss (W)
4F0005	4.8	37	49	87
4F0006	5.5	48	53	101
4F0009	9.2	68.5	61	129.5
4F0015	14.8	135.4	85.7	221.1
4F0018	18.0	149.9	97	246.9
4F0024	24	208	115.1	323.2
4F0031	31	262.6	140.8	403.4
4F0039	39	329.8	179.4	509.2
4F0045	45	348.5	169.6	518.1
4F0060	60	484.1	217.2	701.3
4F0075	75	563.4	254	817.4
4F0091	91	722.6	299	1021.7
4F0112	112	908.2	416.4	1324.6
4F0150	150	1340.3	580.1	1920.3
4F0180	180	1771.4	541	2312.5
4F0216	216	2360.2	715.1	3075.3

Connections for braking unit and braking resistor

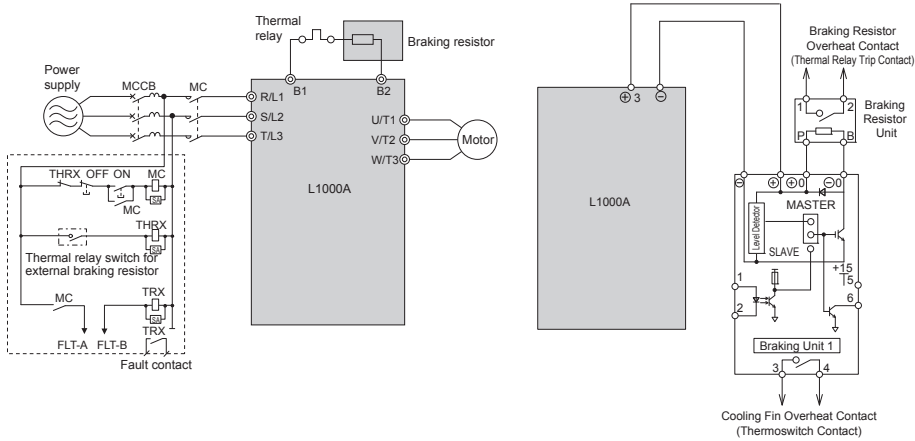

Input AC reactor

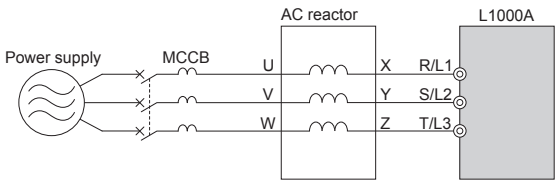

400 V class		
Max. applicable motor output kW	Current value A	Inductance mH
1.5	5	7.7
2.2 to 4.0	10	3.5
5.5 to 7.5	17	1.3
11.0 to 15.0	33.5	0.74
18.5 to 22.0	50	0.36
30.0 to 37.0	78	0.29
45.0 to 55.0	115	0.19
75.0 to 90.0	185	0.11
110.0	270	0.07

DC reactor

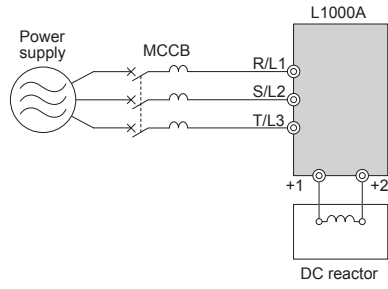

400 V class		
Max. applicable motor output kW	Current value A	Inductance mH
1.5	4.7	14
2.2	6.9	10.1
4.0	11.6	6.4
5.5	16.7	4.41
7.5	21.9	3.35
11.0	30.7	2.33
15.0	43.0	1.75
18.5	64.4	1.2
22.0 to 110.0	Built-in	

Safety System

- L1000A provides Safe Torque Off (STO) functional safety in compliance with ISO/EN13849-1/AC: 2009 PLe (Cat3), IEC EN 61508: 2010 SIL 3, IEC EN 62061: 2005 (SILCL3), IEC EN 61800-5-2: 2007 (SIL 3), IEC EN 61326-3-1: 2008 (EMC-related) and EN81-1/2/20.
- An External Device Monitor (EDM) function has also been added to monitor the safety status of the drive.

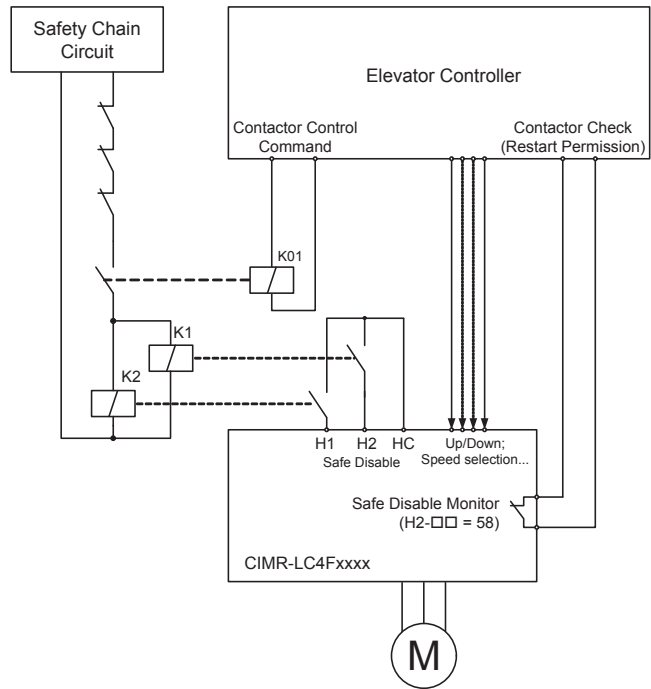

D1000 kit - DC Supply with Regenerative Active Front End system

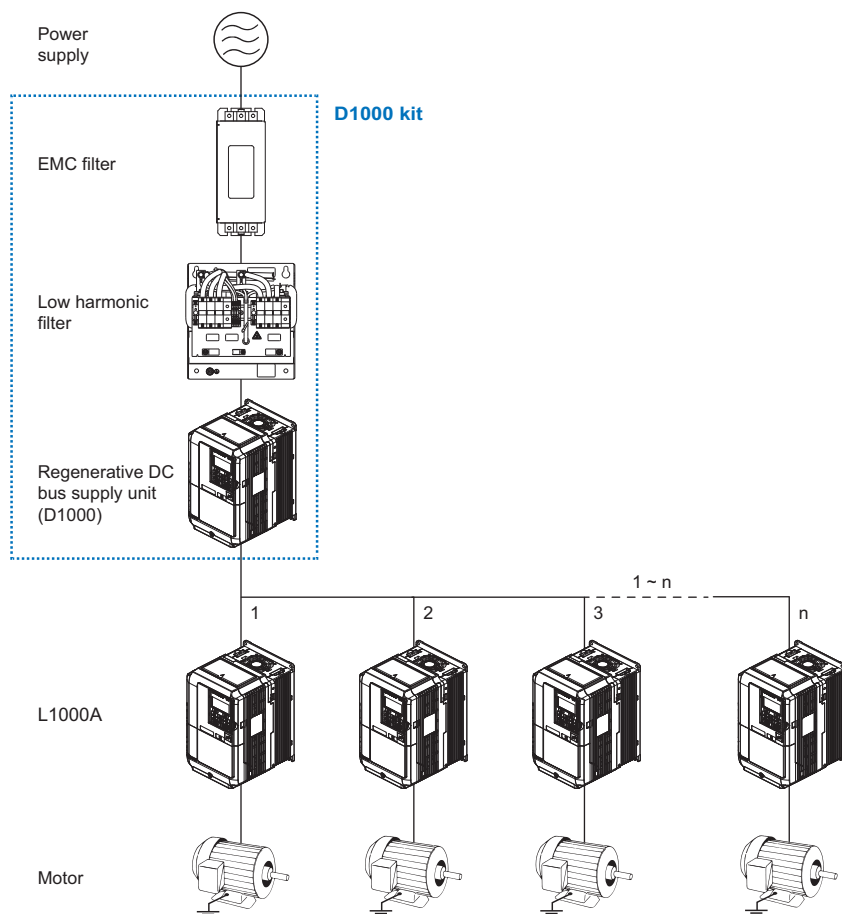

Regenerative DC bus supply unit (D1000)

Reference: CIMR-DC□	4A0005	4A0010	4A0020	4A0030	4A0040	4A0060	4A0100	4A0130
Max. applicable motor capacity (kW)	3.7	7.5	15	22	30	45	75	110
Rated output capacity (kW) ¹	5	10	20	30	40	60	100	130
Rated input current AC (A)	8	16	30	43	58	86	145	210
Rated output current DC (A)	8	15	30	45	61	91	152	197
Rated input voltage	3-phase 380 to 480 VAC							
Rated output voltage	660 VDC							
Rated frequency	50/60 Hz							
Input power factor	> 0.99							
Carrier frequency	6							
Degree of protection	IP20 (CIMR-DC4A0005 to CIMR-DC4A0020 models) IP00 (CIMR-DC4A0030 to CIMR-DC4A0130 models)							
Ambient humidity	95% RH or less (without condensation)							
Storage temperature	-20 to 60°C							
Ambient temperature	-10 to 50°C							

*1. Rated output capacity is calculated with a rated input voltage of 400 V.

EMC filter

Reference: B84143□	A0020R106	A0035R106	A0065R106	B0180S080	B0400S080
Rated current (A)	20	35	65	180	400
Leakage current (mA)	3.1	3.4	3.4	< 21	< 21
Rated voltage	300/520 VAC				
Rated frequency	50/60 Hz				
Rated temperature	50°C				
Degree of protection	IP20				

Low harmonic filter

Reference: B84143G□	0008R176	0016R176	0030R176	0043R176	0058R176	0086R176	0145R176	0210S176
Rated current (A)	8	16	30	43	58	86	145	210
Heat loss (W) ¹	75	140	165	240	260	300	515	665
Rated voltage	305/530 VAC							
Rated frequency	50/60 Hz							
Rated temperature	50°C							
Degree of protection	IP00							

*1. Heat loss at nominal current and 20°C winding temperature with harmonics.

R1000 kit - Regenerative Braking unit system

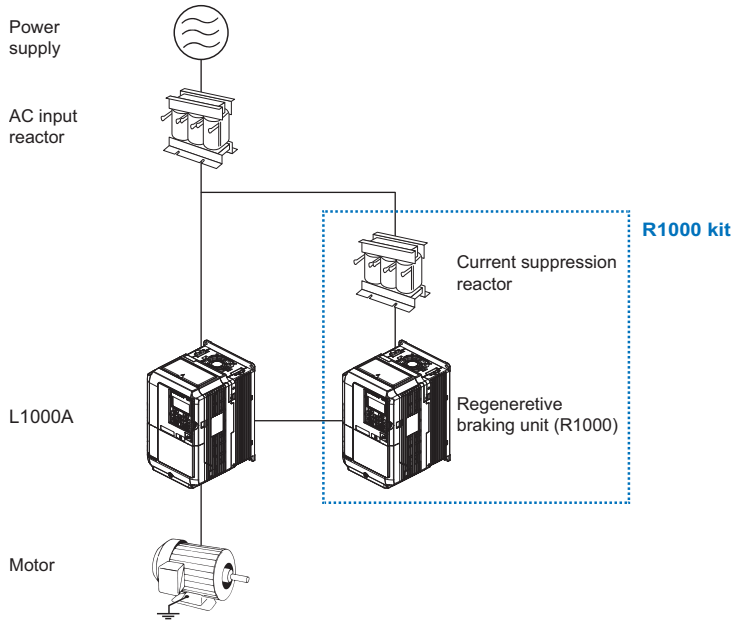

Regenerative Braking unit (R1000)

Reference: CIMR-RC□	4A03P5	4A0005	4A0007	4A0010	4A0014	4A0017	4A0020	4A0028	4A0035	4A0043	4A0053	4A0073	4A0105
Max. applicable motor capacity (kW)	3.7	5.5	7.5	11	15	18.5	22	30	37	45	55	75	110
Rated output capacity (kW)*1	3.5	5	7	10	14	17	20	28	35	43	53	73	105
Rated input current AC (A)	5	8	11	16	22	27	32	43	54	66	81	110	161
Rated output current DC (A)	7	11	15	22	30	36	43	58	73	89	109	149	217
Rated input voltage	3-phase 380 to 480 VAC												
Rated frequency	50/60 Hz												
Power factor	> 0.9 at full load												
Degree of protection	IP20 (CIMR-RC4A03P5 to CIMR-RC4A0028 models) IP00 (CIMR-RC4A0035 to CIMR-RC4A0105 models)												
Ambient humidity	95% RH or less (without condensation)												
Storage temperature	-20 to 60°C												
Ambient temperature	-10 to 50°C												

*1. Rated output capacity is calculated with a rated input voltage of 400 V.

Current suppression reactor

Reference: B150□	9105	9106	9107	9108	9109	9110	4118	9111	9112	9113	9114
Rated current (A)	7.5	10	15	25	30	40	50	60	75	100	161
Inductance (mH)	1.2	0.6	0.4	0.3	0.2	0.15	0.12	0.1	0.08	0.06	0.04
Heat loss (W)	21	19	23	36	33	40	46	56	81	72	95

Ordering information

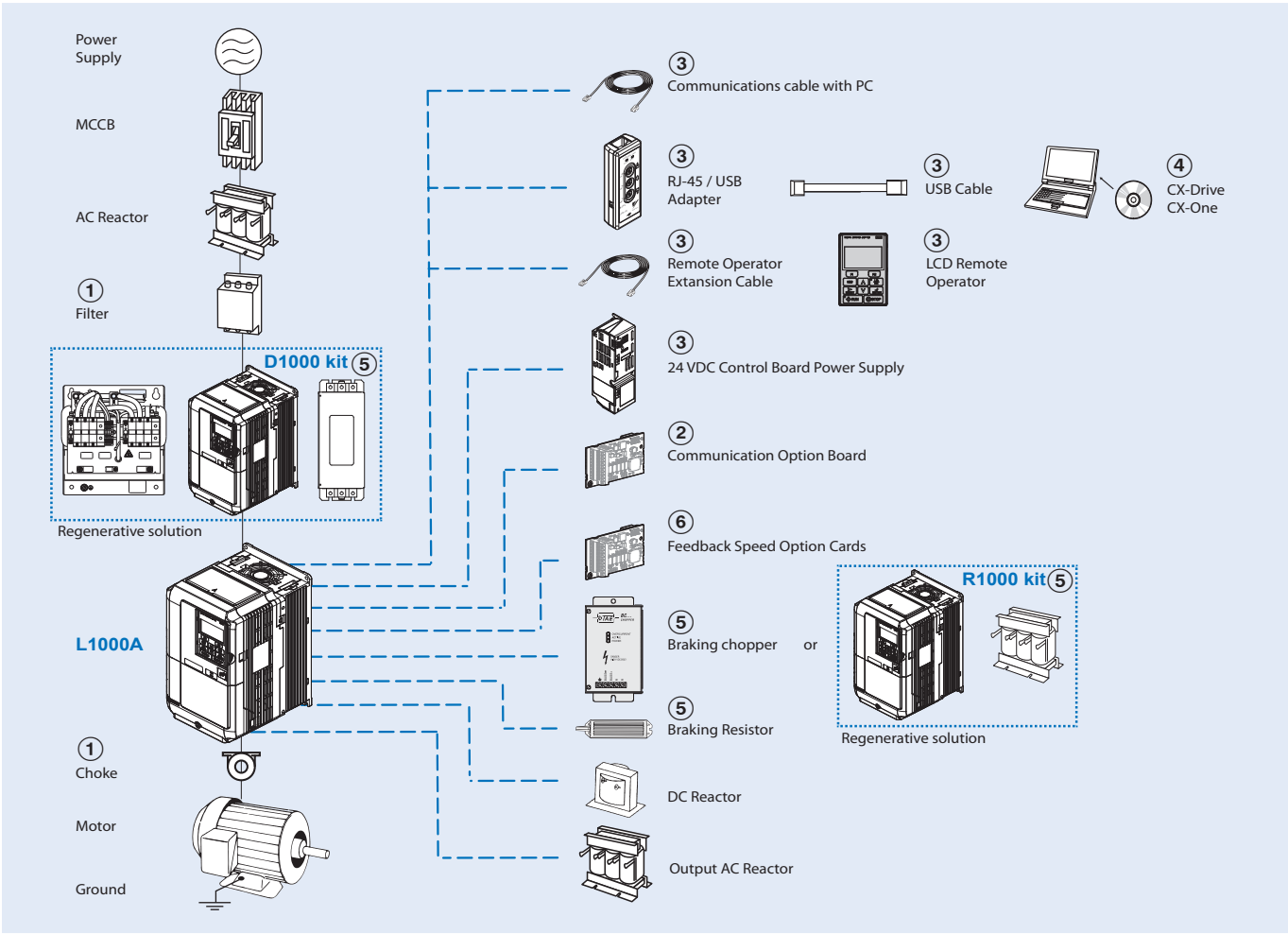

L1000A

Voltage	Specifications		Model	
	Heavy Duty		Standard	Special model (A3 Brake monitoring/DCP3)
400 V	1.5 kW	4.8 A	CIMR-LC4F0005BAC	CIMR-LC4F0005BAC-9130
	2.2 kW	5.5 A	CIMR-LC4F0006BAC	CIMR-LC4F0006BAC-9130
	4.0 kW	9.2 A	CIMR-LC4F0009BAC	CIMR-LC4F0009BAC-9130
	5.5 kW	14.8 A	CIMR-LC4F0015BAC	CIMR-LC4F0015BAC-9130
	7.5 kW	18 A	CIMR-LC4F0018BAC	CIMR-LC4F0018BAC-9130
	11 kW	24 A	CIMR-LC4F0024BAC	CIMR-LC4F0024BAC-9130
	15 kW	31 A	CIMR-LC4F0031BAC	CIMR-LC4F0031BAC-9130
	18.5 kW	39 A	CIMR-LC4F0039BAC	CIMR-LC4F0039BAC-9130
	22 kW	45 A	CIMR-LC4F0045BAC	CIMR-LC4F0045BAC-9130
	30 kW	60 A	CIMR-LC4F0060BAC	CIMR-LC4F0060BAC-9130
	37 kW	75 A	CIMR-LC4F0075BAC	CIMR-LC4F0075BAC-9130
	45 kW	91 A	CIMR-LC4F0091BAC	CIMR-LC4F0091BAC-9130
	55 kW	112 A	CIMR-LC4F0112BAC	CIMR-LC4F0112BAC-9130
	75 kW	150 A	CIMR-LC4F0150BAC	CIMR-LC4F0150BAC-9130
90 kW	180 A	CIMR-LC4F0180BAC	CIMR-LC4F0180BAC-9130	
110 kW	216 A	CIMR-LC4F0216BAC	CIMR-LC4F0216BAC-9130	

① Line filters

Drive		Line filter Rasmi			Line filter Schaffner		
Voltage	Model CIMR-LC□	Reference	Rated current (A)	Weight (kg)	Reference	Rated current (A)	Weight (kg)
3-Phase 400 VAC	4F0005 / 4F0006	A1000-FIA3024-RE	24	2.0	3G3RV-PFI3010-SE	10	1.2
	4F0009				3G3RV-PFI3018-SE	18	1.3
	4F0015 / 4F0018				3G3RV-PFI3035-SE	35	2.2
	4F0024	A1000-FIA3044-RE	44	2.8	3G3RV-PFI3060-SE	60	4.0
	4F0031	A1000-FIA3052-RE	52	3.9			
	4F0039		71	5.3			
	4F0045		A1000-FIA3071-RE	105	6.5	3G3RV-PFI3100-SE	100
	4F0060	A1000-FIA3105-RE	105	6.5	3G3RV-FPI3170-SE	170	6.0
	4F0075						
	4F0091	A1000-FIA3170-RE	170	9	3G3RV-PFI3200-SE	250	11.0
	4F0112 / 4F0150						
	4F0180 / 4F0216						

① Chokes

Model	Diameter	Description
AX-FER2102-RE	21	Recommended for motors below 2.2 KW
AX-FER2815-RE	28.5	Recommended for motors below 15 KW
AX-FER5045-RE	50	Recommended for motors below 45 KW
AX-FER6055-RE	60	Recommended for motors above 45 KW

② Communication cards

Type	Model	Description	Function
Communication option board	SI-S3	CANopen option card	<ul style="list-style-type: none"> Used for controlling the drive, setting or referencing parameters, and monitoring output frequency, output current, or similar items through CANopen communication with the host controller.

③ Accessories

Types	Model	Description	Functions
Digital operator	JVOP-180	LCD remote operator	LCD Display operator with language support
	JVOP-182	LED remote operator	LED Display operator
	3G3AX-CAJOP300-EE	Remote operator cable	3 meters cable for connecting remote operator
Accessories	JVOP-181	USB converter / USB cable	USB converter unit with copy and backup function
	PS-A10L	24 VDC option board	24V DC control board power supply 200V type
	PS-A10H		24V DC control board power supply 400V type
	A1000-CAVPC232-EE	PC connection cable	RS232 PC tool connection cable

④ Computer software

Types	Model	Description	Installation
Software	CX-Drive	Computer software	Configuration and monitoring software tool
	CX-One	Computer software	Configuration and monitoring software tool

⑤ D1000 kit - DC Supply with Regenerative Active Front End

Rated power kW	D1000 kit			
	Regenerative DC bus supply unit (D1000) ^{*1}	EMC filter ^{*1}	Low harmonic filter ^{*1}	Kit code
5	CIMR-DC4A0005BAA	B84143A0020R106	B84143G0008R176	D1KIT40005AAAAAB
10	CIMR-DC4A0010BAA		B84143G0016R176	D1KIT40010AAAAAB
20	CIMR-DC4A0020BAA	B84143A0035R106	B84143G0030R176	D1KIT40020AAAAAB
30	CIMR-DC4A0030AAA	B84143A0065R106	B84143G0043R176	D1KIT40030AAAAAB
40	CIMR-DC4A0040AAA		B84143G0058R176	D1KIT40040AAAAAB
60	CIMR-DC4A0060AAA	B84143B0180S080	B84143G0086R176	D1KIT40060AAAAAB
100	CIMR-DC4A0100AAA	B84143B0400S080	B84143G0145R176	D1KIT40100AAAAAB
130	CIMR-DC4A0130AAA		B84143G0210S176	D1KIT40130AAAAAB

*1. It is not possible to purchase the Regenerative DC bus supply unit (D1000), EMC filter and low harmonic filter as a separate items.

⑤ R1000 kit - Regenerative Braking unit

Rated power kW	R1000 kit		
	Regenerative braking unit (R1000) ^{*1}	Current suppression reactor (1%) ^{*1}	Kit code
3.5	CIMR-RC4A03P5FAA	B1509105	R1KIT40003AAAAAA
5	CIMR-RC4A0005FAA		R1KIT40005AAAAAA
7	CIMR-RC4A0007FAA	B1509106	R1KIT40007AAAAAA
10	CIMR-RC4A0010FAA	B1509107	R1KIT40010AAAAAA
14	CIMR-RC4A0014FAA	B1509108	R1KIT40014AAAAAA
17	CIMR-RC4A0017FAA		R1KIT40017AAAAAA
20	CIMR-RC4A0020FAA	B1509109	R1KIT40020AAAAAA
28	CIMR-RC4A0028FAA	B1509110	R1KIT40028AAAAAA
35	CIMR-RC4A0035AAA	B1504118	R1KIT40035AAAAAA
43	CIMR-RC4A0043AAA	B1509111	R1KIT40043AAAAAA
53	CIMR-RC4A0053AAA	B1509112	R1KIT40053AAAAAA
73	CIMR-RC4A0073AAA	B1509113	R1KIT40073AAAAAA
105	CIMR-RC4A0105AAA	B1509114	R1KIT40105AAAAAA

*1. It is not possible to purchase the Regenerative braking unit (R1000) and current suppression reactor as a separate items.

⑤ Braking unit, braking resistor unit

Drive		Braking unit		Braking Resistor ^{*1}					
Max. Applicable Motor kW	Model CIMR-LC□	Model AX-BCR_	Qty	Model AX-REM	Specifications of Resistor		Qty	Min Resist Value Ω	
400 V class	1.5	4F0005	Built in	00K9120-IE	900 W	120 Ω	1	64	
	2.2	4F0006		01K9040-IE	1900 W	40 Ω	1	32	
	4.0	4F0009			03K5025-IE	3500 W	25 Ω	1	20
	5.5	4F0015		03K5035-IE		3500 W	35 Ω	1	20
	7.5	4F0018			19K0030-IE	19000 W	30 Ω	1	19.2
	11	4F0024		19K0020-IE		19000 W	20 Ω	1	19.2
	15	4F0031			19K0030-IE	19000 W	30 Ω	3	8.5
	18.5	4F0039		38K0012-IE		38000 W	12 Ω	2	6
	22	4F0045			4035090-TE	1	4070130-TE	1	-
	30	4F0060		1					
	37	4F0075	1						
	45	4F0091	1						
	55	4F0112	1	1	1	1	1	1	
	75	4F0150	1	1	1	1	1	1	
90	4F0180	1	1	1	1	1	1		
110	4F0216	1	1	1	1	1	1		

*1. Additionally the Internal braking transistor protection (L8-55) should be set to "0" when a external braking unit (AX-BCR) is used.

⑥ Feedback speed option card

Type	Model	Description	Function
PG option card	PG-B3	Complementary PG	<ul style="list-style-type: none"> For speed feedback input by connecting a motor encoder Input: 3 track (one or two tracks), for HTL encoder connection, 50 KHz max Output: 3 track open collector Encoder power supply: 12 V, 200 mA max
	PG-X3	Line Driver PG	<ul style="list-style-type: none"> For speed feedback input by connecting a motor encoder Input: 3 track, line driver, 300 kHz max Output: 3 track, line driver Encoder power supply: 5 V or 12 V, 200 mA max
	PG-F3	Endat encoder PG	<ul style="list-style-type: none"> For speed feedback input by connection a motor encoder Encoder type: EnDat 2.1/01, EnDat 2.2/01 (HEIDENHAIN) Maximum input frequency: 50KHz Pulse monitor: Matches RS-422 level Output voltage: 5 V +/-5%, 8 V +/-10% Maximum output current: 200mA Wiring length: 20m max. for the encoder, 30m max for the pulse monitor
	PG-E3	ERN1387 encoder PG	<ul style="list-style-type: none"> For speed feedback input by connection a motor encoder Encoder type: ERN1387 (HEIDENHAIN) Maximum input frequency: 50KHz Pulse monitor: Matches RS-422 level Output voltage: 5 V +/-5% Maximum output current: 200mA Wiring length: 20m max. for the encoder, 30m max for the pulse monitor
	PG-RT3	Motor feedback resolver interface	<ul style="list-style-type: none"> For motor speed feedback by connecting a resolver (TS2640N321E64 by Tamagawa Seiki Co., LTD) Input voltage: 7 VAC rms 10 kHz Transformation ratio: 0.5 +/-5% Maximum input current: 100 mA rms

ALL DIMENSIONS SHOWN ARE IN MILLIMETERS.

To convert millimeters into inches, multiply by 0.03937. To convert grams into ounces, multiply by 0.03527.